

Memo

滑台系列

ETH Series

一般環境 / 螺桿式樣
Standard/Ball Screw

精度
±0.005
mm

CONTENTS

一般環境 / 螺桿式樣 Standard/Ball Screw Type

中型 MEDIUM

ETH13

低價格 中荷重



本體寬幅 135mm
Width
最大行程 1050mm217
Max. stroke
最大荷重 70kg
Max. payload

中型 MEDIUM

ETH14

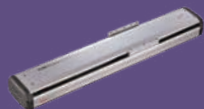

本體寬幅 135mm
Width
最大行程 1050mm229
Max. stroke
最大荷重 110kg
Max. payload

大型 LARGE

ETH17

高荷重

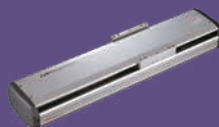

本體寬幅 170mm
Width
最大行程 1250mm241
Max. stroke
最大荷重 120kg
Max. payload

大型 LARGE

ETH22

高荷重



本體寬幅 220mm
Width
最大行程 1500mm251
Max. stroke
最大荷重 150kg
Max. payload

長行程系列 Long Stroke Ball Screw Actuator

大型 LARGE

ETH17M

長行程 高荷重

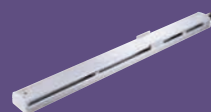

本體寬幅 170mm
Width
最大行程 2200mm257
Max. stroke
最大荷重 120kg
Max. payload

大型 LARGE

ETH22M

長行程 高荷重

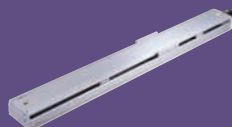

本體寬幅 220mm
Width
最大行程 2400mm267
Max. stroke
最大荷重 130kg
Max. payload

滑台模組規格索引

Spec Index of Electric Actuator

ETH 標準螺桿滑台系列

ETH Ball Screw Actuator - Slider Type

使用環境 Environment	傳動方式 Driven Mode	仕樣 Specification	馬達容量 Motor Output (w)	本體寬幅 Width(mm)	位置重複精度 Repeatability(mm)	螺桿規格 (C7 級) Ball Screw Spec		最大可搬重量 Maximum Payload(kg)		最高速度 ^{*1} Maximum Speed (mm/s)
						外徑 Outer Diameter(mm)	導程 Lead(mm)	水平使用 Horizontal	垂直使用 Vertical	
一般環境 Standard	滾珠螺桿 Ball screw	ETH13	200W	135	±0.005	16	5	70	17	300
							10	47	12	600
							20	24	6	1200
							32	13	-	1920
		ETH14	400W	135	±0.005	16	5	70	17	300
							10	47	12	600
							20	24	6	1200
							32	13	-	1920
		ETH14	200W	135	±0.005	16	5	95	27	300
							10	75	18	600
							20	35	7	1200
							32	15	-	1920
		ETH17	400W	170	±0.005	16	5	110	33	300
							10	88	22	600
							20	40	10	1200
							32	30	8	1920
		ETH17	400W	170	±0.005	20	5	120	40	300
							10	110	30	600
							20	75	14	1200
							40	22	7	2400
ETH17	750W	170	±0.005	20	5	120	50	300		
					10	120	40	600		
					20	83	25	1200		
					40	43	12	2400		
ETH22	750W	220	±0.005	25	5	150	55	300		
					10	150	45	600		
					25	105	20	1500		
					40	43	12	2400		

*1: 最高速度 (mm/s) 是以伺服馬達最高轉速，導程 2 為 3000RPM 為計算基準，其餘導程為 3600RPM 為計算基準。

The maximum speed (mm/s) is based on the maximum rotating speed of the servo motor. Lead 2 is calculated on a 3000RPM basis, and the other leads are calculated on a 3600RPM basis.

*2: 標準行程內的黑色數字，代表該行程內可使用的最高安全速度。若超過此速度，滑台可能會有嚴重共振產生。

Written here is the standard stroke's maximum safe speed. If over this speed, it may cause serious vibration.

長行程系列

Long Stroke Ball Screw Actuator

使用環境 Environment	傳動方式 Driven Mode	仕樣 Specification	馬達容量 Motor Output (w)	本體寬幅 Width(mm)	位置重複精度 Repeatability(mm)	螺桿規格 (C7 級) Ball Screw Spec		最大可搬重量 Maximum Payload(kg)		最高速度 ^{*1} Maximum Speed (mm/s)
						外徑 Outer Diameter(mm)	導程 Lead(mm)	水平使用 Horizontal	垂直使用 Vertical	
一般環境 Standard	滾珠螺桿 Ball screw	ETH17M	400W	170	±0.005	16	5	110	33	300
							10	90	22	600
							20	40	10	1200
							32	30	8	1920
		ETH17M	750W	170	±0.005	16	5	120	40	300
							10	95	25	600
							20	50	15	1200
							32	35	12	1920
		ETH22M	750W	220	±0.005	20	5	130	50	300
							10	130	40	600
							20	85	25	1200
							40	43	12	2400

*1: 最高速度 (mm/s) 是以伺服馬達最高轉速，導程 2 為 3000RPM 為計算基準，其餘導程為 3600RPM 為計算基準。

The maximum speed (mm/s) is based on the maximum rotating speed of the servo motor. Lead 2 is calculated on a 3000RPM basis, and the other leads are calculated on a 3600RPM basis.

*2: 標準行程內的黑色數字，代表該行程內可使用的最高安全速度。若超過此速度，滑台可能會有嚴重共振產生。

Written here is the standard stroke's maximum safe speed. If over this speed, it may cause serious vibration.

免費服務專線：大陸 400-875-0009 台灣 0800-800-893
 Toll-Free Number China Taiwan

應用例
Application

一般 / 螺桿仕様
ETH

一般 / 皮帶仕様
ETB / M

無塵 / 螺桿仕様
GCH / ECH

無塵 / 皮帶仕様
ECB

直交連結
XYGT / XTH / XYTB

參考資料
Reference

標準行程及最高使用速度 ^{*2} Stroke(mm) & Maximum Speed(mm/s)		代表速度 Speed															Page														
行程 Stroke	50	100	150	200	250	300	350	400	450	500	550	600	650	700	750	800	850	900	950	1000	1050	1100	1150	1200	1250	1300	1350	1400	1450	1500	
300														267	250	225	200	175	150	125	100										
600														533	500	450	400	350	300	250	200										
1200														1067	1000	900	800	700	600	500	400										
1920														1707	1600	1440	1280	1120	960	800	640										
300														267	250	225	200	175	150	125	100										
600														533	500	450	400	350	300	250	200										
1200														1067	1000	900	800	700	600	500	400										
1920														1707	1600	1440	1280	1120	960	800	640										
300														275	250	225	200	175	150	125	100										
600														550	500	450	400	350	300	250	200										
1200														1100	1000	900	800	700	600	500	400										
1920														1760	1600	1440	1280	1120	960	800	640										
300														275	250	225	200	175	150	125	100										
600														550	500	450	400	350	300	250	200										
1200														1100	1000	900	800	700	600	500	400										
1920														1760	1600	1440	1280	1120	960	800	640										
300																						267	250	225	200	175	150				
600																						533	500	450	400	350	300				
1200																						1067	1000	900	800	700	600				
2400																						2133	2000	1800	1600	1400	1200				
300																						267	250	225	200	175	150				
600																						533	500	450	400	350	300				
1200																						1067	1000	900	800	700	600				
2400																						2133	2000	1800	1600	1400	1200				
300																						275	250	225	200	175	150	125	100		
600																						550	500	450	400	350	300	250	200		
1500																						1375	1250	1125	1000	875	750	625	500		
2400																						2200	2000	1800	1600	1400	1200	1000	800	600	

標準行程及最高使用速度 ^{*2} Stroke(mm) & Maximum Speed(mm/s)		代表速度 Speed															Page											
行程 Stroke	1100	1150	1200	1250	1300	1350	1400	1450	1500	1550	1600	1650	1700	1750	1800	1850	1900	1950	2000	2050	2100	2150	2200	2250	2300	2350	2400	
300																												
600																												
1200																												
1920																												
300																												
600																												
1200																												
1920																												
300																												
600																												
1200																												
1920																												
300																												
600																												
1200																												
2400																												

ETH13 單軸 /1-axis

▶ 螺桿驅動
Ball Screw Drive

精度
±0.005 mm



- 最大行程 Maximum Stroke: 1050mm
- 最高速度 Maximum Speed: 1920mm/s
- 馬達容量 Motor Output: 200W
- 滾珠螺桿 Ball Screw: ø16mm
- 直線滑軌 Linear Guide: 15X12.5-2 支

型號表示方式 Ordering Method

ETH13 - L5 - 50 - BC - M20B - C4N5 - 參照右頁
Refer to the right page. - 0001

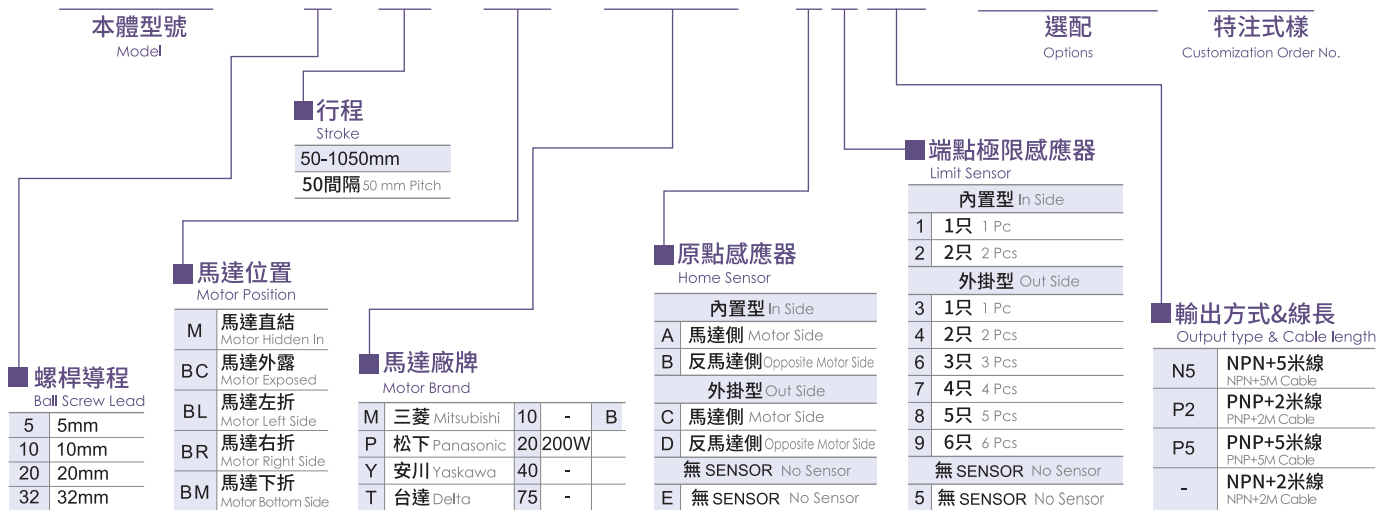

*若無煞車則不表示。†† No Brake, No Description.

*感應器由客戶自行安裝,圖面最多示意為3只

*The sensors are installed by customers themselves, and the diagram shows a maximum of 3 sensors.

基本仕様 Specification

性能	位置重複精度 Repeatability	mm	±0.005				
	螺桿導程 Lead	mm	5	10	20	32	
	最高轉速 Maximum Rotating speed	rpm	3600	3600	3600	3600	
	最高速度 Maximum linear speed ^{※1}	mm/s	300	600	1200	1920	
	最大可搬重量 Maximum Payload	水平使用 Horizontal	kg	70	47	24	13
		垂直使用 Vertical	kg	17	12	6	-
	定格推力 Rated Thrust	N	683	341	174	107	
部品	標準行程 Stroke (increments)	mm	50-1050mm/50 間隔 (50 increments)				
	AC 伺服馬達容量 AC Servo Motor Output	W	200				
	滾珠螺桿外徑 Ball Screw Ø	mm	C7Ø16				
	高剛性直線滑軌 High Rigidity Linear Guide	mm	W15XH12.5				
	連軸器 Coupling	mm	10X14/11 ^{※2}				
	原點感應器 Home Sensor	外掛 Outside		T62N2 (NPN+2 米線) (NPN+2M Cable)			
		內置 Built-In		T64N2 (NPN+2 米線) (NPN+2M Cable)			

※1 長行程時，會產生螺桿偏擺，需將速度調降 (線速度請參閱尺寸圖下方表格)
During in a long stroke, it causes ballscrew deflection, the speed must reduce. (Please refer to the linear velocity from the data sheet below the dimension graph.)
※2 使用 Panasonic 200W 馬達時，馬達軸心為 Ø11；其他廠牌，馬達軸心為 Ø14。
Motor (200W) Shaft Diameter: Panasonic: 11mm; Other: 14mm.

容許負載力距表 Allowable Overhang

水平安裝 Horizontal Installation				壁掛安裝 Wall Installation				垂直安裝 Vertical Installation		
導程 Lead	重量 Weight	A	B	A	B	C	導程 Lead	A	C	
5	40kg	647	62	211	62	647	5	5kg	567	567
	55kg	453	42	145	42	453	5	11kg	258	258
	70kg	342	31	107	31	342		17kg	167	167
10	25kg	470	91	245	91	470	10	4kg	616	616
	35kg	327	62	168	62	327	10	8kg	308	308
	47kg	235	44	120	44	235		12kg	205	205
20	6kg	772	308	546	308	772	20	2kg	868	868
	15kg	299	117	210	117	299	20	3kg	578	578
	24kg	181	70	126	70	126		6kg	289	289
32	3kg	660	422	528	422	660	32	3kg	578	578
	7kg	277	175	221	175	221	32	7kg	221	221
	13kg	145	90	115	90	115		13kg	115	115

靜額定扭矩 Static Loading Moment

MY	174
MP	175
MR	153

* 力矩表所表示的數據，代表荷重的重心位置於單一方容許懸出的長度。
The data represented by the moment table is the center of gravity of the load. The length of the overhang is allowed in a single direction.
* 符合型錄規範的正常使用下，保證壽命為 10000 公里。
Operation life is 10,000km when the product is using under the specified conditions.
* 倒吊使用無法套用標準規範，如有需求請洽詢我司業務。
Data information is not for ceiling-mount inverse use. Contact us for the details if you want to apply ceiling-mount inverse usage.
* 壽命及力矩是以馬達加減速設定 0.2 秒計算。
The life and torque are calculated by setting the motor acceleration and deceleration for 0.2 seconds.

選配 Options

NL	P	EB	MM	CMK																																																								
外拉式注油嘴位置 External oil injection nozzle position <table border="1"> <tr><th>代號 Code</th><th>說明 Instructions</th><th>需參照 Refer to</th></tr> <tr><td>NL</td><td>滑座右側 On The Right of The Slider</td><td rowspan="3">P.675 ~ P.676</td></tr> <tr><td>NR</td><td>滑座右側 On The Right of The Slider</td></tr> <tr><td>NRL</td><td>滑座雙邊注油 Slide both sides for oil injection</td></tr> </table>	代號 Code	說明 Instructions	需參照 Refer to	NL	滑座右側 On The Right of The Slider	P.675 ~ P.676	NR	滑座右側 On The Right of The Slider	NRL	滑座雙邊注油 Slide both sides for oil injection	標準 PIN 孔 Standard PIN hole <table border="1"> <tr><th>代號 Code</th><th>說明 Instructions</th><th>需參照 Refer to</th></tr> <tr><td>P</td><td>標準 PIN 孔 Standard PIN hole</td><td>P.677</td></tr> </table>	代號 Code	說明 Instructions	需參照 Refer to	P	標準 PIN 孔 Standard PIN hole	P.677	外觀黑色處理 Outer layer is treated with black oxide <table border="1"> <tr><th>代號 Code</th><th>說明 Instructions</th><th>需參照 Refer to</th></tr> <tr><td rowspan="2">EB</td><td>黑色 Black</td><td>本體 Main Body</td><td rowspan="2">P.678</td></tr> <tr><td>原色 Original color</td><td>不銹鋼板材 Screw</td></tr> </table>	代號 Code	說明 Instructions	需參照 Refer to	EB	黑色 Black	本體 Main Body	P.678	原色 Original color	不銹鋼板材 Screw	指定馬達出線方向 Selectable Cable Leading Direction <table border="1"> <tr><th>代號 Code</th><th>說明 Instructions</th><th>需參照 Refer to</th></tr> <tr><td>MW</td><td>朝上 Upper side</td><td rowspan="4">P.679 ~ P.680</td></tr> <tr><td>MM</td><td>朝下 Bottom side</td></tr> <tr><td>ML</td><td>朝左 Left side</td></tr> <tr><td>MR</td><td>朝右 Right side</td></tr> </table>	代號 Code	說明 Instructions	需參照 Refer to	MW	朝上 Upper side	P.679 ~ P.680	MM	朝下 Bottom side	ML	朝左 Left side	MR	朝右 Right side	馬達傳動配件追加鍵槽 Additional keyway for motor drive parts <table border="1"> <tr><th>代號 Code</th><th>說明 Instructions</th><th>需參照 Refer to</th></tr> <tr><td rowspan="2">CMK</td><td>單邊 (限馬達側) Single (Limited to the motor side)</td><td>BC/M 鍵槽式聯軸器 Keyway Coupling</td><td rowspan="4">P.681 ~ P.682</td></tr> <tr><td>雙邊 Double</td><td>BL/BR/BM 鍵槽式皮帶輪 Keyway Belt Pulley</td></tr> <tr><td rowspan="2">SKY</td><td>雙邊 Double</td><td>BC/M 鍵槽式聯軸器 Keyway Coupling</td></tr> <tr><td>雙邊 Double</td><td>BL/BR/BM 不適用 Not Applicable</td></tr> <tr><td rowspan="2">SKN</td><td>雙邊 Double</td><td>BC/M 無聯軸器 (請自行購買安裝) Without Coupling (Please purchase and install by yourself)</td></tr> <tr><td>雙邊 Double</td><td>BL/BR/BM 不適用 Not Applicable</td></tr> </table>	代號 Code	說明 Instructions	需參照 Refer to	CMK	單邊 (限馬達側) Single (Limited to the motor side)	BC/M 鍵槽式聯軸器 Keyway Coupling	P.681 ~ P.682	雙邊 Double	BL/BR/BM 鍵槽式皮帶輪 Keyway Belt Pulley	SKY	雙邊 Double	BC/M 鍵槽式聯軸器 Keyway Coupling	雙邊 Double	BL/BR/BM 不適用 Not Applicable	SKN	雙邊 Double	BC/M 無聯軸器 (請自行購買安裝) Without Coupling (Please purchase and install by yourself)	雙邊 Double	BL/BR/BM 不適用 Not Applicable
代號 Code	說明 Instructions	需參照 Refer to																																																										
NL	滑座右側 On The Right of The Slider	P.675 ~ P.676																																																										
NR	滑座右側 On The Right of The Slider																																																											
NRL	滑座雙邊注油 Slide both sides for oil injection																																																											
代號 Code	說明 Instructions	需參照 Refer to																																																										
P	標準 PIN 孔 Standard PIN hole	P.677																																																										
代號 Code	說明 Instructions	需參照 Refer to																																																										
EB	黑色 Black	本體 Main Body	P.678																																																									
	原色 Original color	不銹鋼板材 Screw																																																										
代號 Code	說明 Instructions	需參照 Refer to																																																										
MW	朝上 Upper side	P.679 ~ P.680																																																										
MM	朝下 Bottom side																																																											
ML	朝左 Left side																																																											
MR	朝右 Right side																																																											
代號 Code	說明 Instructions	需參照 Refer to																																																										
CMK	單邊 (限馬達側) Single (Limited to the motor side)	BC/M 鍵槽式聯軸器 Keyway Coupling	P.681 ~ P.682																																																									
	雙邊 Double	BL/BR/BM 鍵槽式皮帶輪 Keyway Belt Pulley																																																										
SKY	雙邊 Double	BC/M 鍵槽式聯軸器 Keyway Coupling																																																										
	雙邊 Double	BL/BR/BM 不適用 Not Applicable																																																										
SKN	雙邊 Double	BC/M 無聯軸器 (請自行購買安裝) Without Coupling (Please purchase and install by yourself)																																																										
	雙邊 Double	BL/BR/BM 不適用 Not Applicable																																																										

ETH13 單軸 /1-axis



M 馬達直結 Motor Hidden In



• CAD圖面可至www.toyorobot.com下載 •
Please download the CAD file from TOYO's website : www.toyorobot.com

單位 Unit : mm

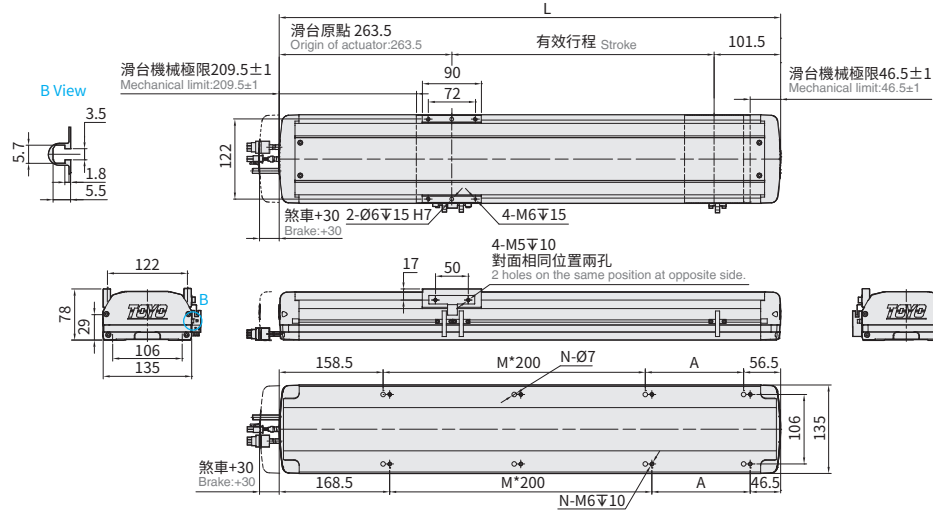

有效行程 Stroke	50	100	150	200	250	300	350	400	450	500	550	600	650	700	750	800	850	900	950	1000	1050	
極限行程 Limit Stroke (±1)	69	119	169	219	269	319	369	419	469	519	569	619	669	719	769	819	869	919	969	1019	1069	
L	415	465	515	565	615	665	715	765	815	865	915	965	1015	1065	1115	1165	1215	1265	1315	1365	1415	
A	200	50	100	150	200	50	100	150	200	50	100	150	200	50	100	150	200	50	100	150	200	
M	0	1	1	1	1	2	2	2	2	3	3	3	3	4	4	4	4	5	5	5	5	
N	4	6	6	6	6	8	8	8	8	10	10	10	10	12	12	12	12	14	14	14	14	
KG	8.3	8.86	9.42	9.98	10.54	11.1	11.66	12.22	12.78	13.34	13.9	14.46	15.02	15.58	16.14	16.7	17.26	17.82	18.38	18.94	19.5	
線速度 Linear Speed mm/s	導程 Lead 5														267	250	225	200	175	150	125	100
	導程 Lead 10														600							
	導程 Lead 20														533	500	450	400	350	300	250	200
	導程 Lead 32														1067	1000	900	800	700	600	500	400

BC 馬達外露 Motor Exposed



• CAD圖面可至www.toyorobot.com下載 •
Please download the CAD file from TOYO's website : www.toyorobot.com

單位 Unit : mm

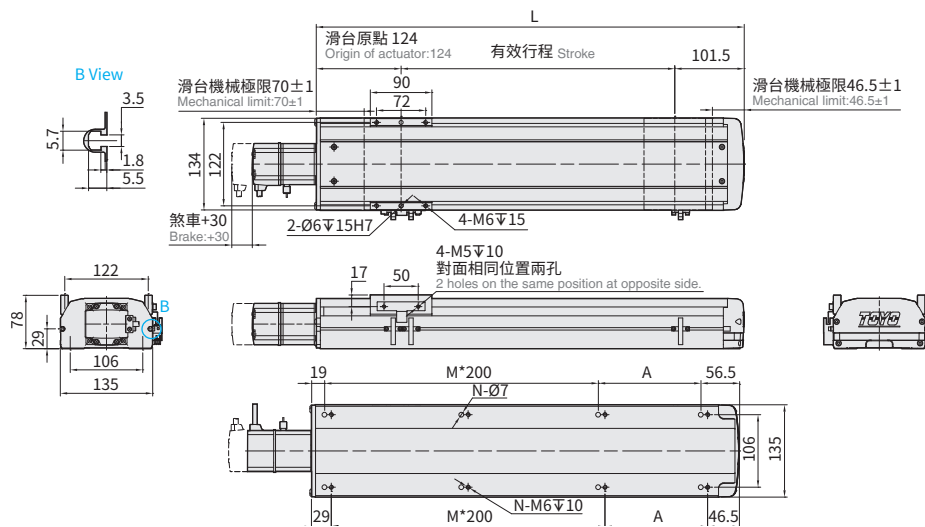

有效行程 Stroke	50	100	150	200	250	300	350	400	450	500	550	600	650	700	750	800	850	900	950	1000	1050	
極限行程 Limit Stroke (±1)	69	119	169	219	269	319	369	419	469	519	569	619	669	719	769	819	869	919	969	1019	1069	
L	275.5	325.5	375.5	425.5	475.5	525.5	575.5	625.5	675.5	725.5	775.5	825.5	875.5	925.5	975.5	1025.5	1075.5	1125.5	1175.5	1225.5	1275.5	
A	200	50	100	150	200	50	100	150	200	50	100	150	200	50	100	150	200	50	100	150	200	
M	0	1	1	1	1	2	2	2	2	3	3	3	3	4	4	4	4	5	5	5	5	
N	4	6	6	6	6	8	8	8	8	10	10	10	10	12	12	12	12	14	14	14	14	
KG	7.4	7.96	8.52	9.08	9.64	10.2	10.76	11.32	11.88	12.44	13	13.56	14.12	14.68	15.24	15.8	16.36	16.92	17.48	18.04	18.6	
線速度 Linear Speed mm/s	導程 Lead 5														267	250	225	200	175	150	125	100
	導程 Lead 10														600							
	導程 Lead 20														533	500	450	400	350	300	250	200
	導程 Lead 32														1067	1000	900	800	700	600	500	400

BL 馬達左折 Motor Left Side



CAD圖面可至www.toyorobot.com下載

Please download the CAD file from TOYO's website : www.toyorobot.com

單位 Unit : mm

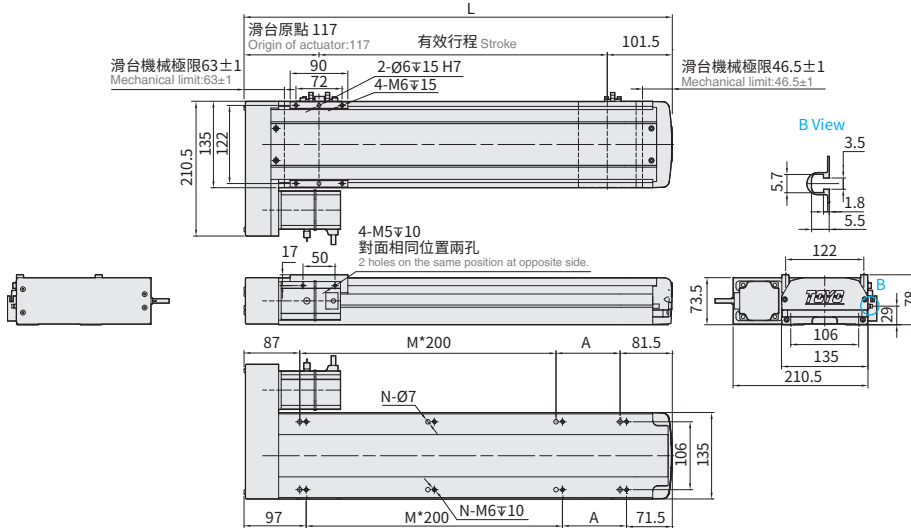

有效行程 Stroke	50	100	150	200	250	300	350	400	450	500	550	600	650	700	750	800	850	900	950	1000	1050						
極限行程 Limit Stroke (± 1)	69	119	169	219	269	319	369	419	469	519	569	619	669	719	769	819	869	919	969	1019	1069						
L	268.5	318.5	368.5	418.5	468.5	518.5	568.5	618.5	668.5	718.5	768.5	818.5	868.5	918.5	968.5	1018.5	1068.5	1118.5	1168.5	1218.5	1268.5						
A	100	150	200	50	100	150	200	50	100	150	200	50	100	150	200	50	100	150	200	50	100						
M	0	0	0	1	1	1	1	2	2	2	2	3	3	3	3	4	4	4	4	5	5						
N	4	4	4	6	6	6	6	8	8	8	8	10	10	10	10	12	12	12	12	14	14						
KG	7.94	8.5	9.06	9.62	10.18	10.74	11.3	11.86	12.42	12.98	13.54	14.1	14.66	15.22	15.78	16.34	16.9	17.46	18.02	18.58	19.14						
線速度 Linear Speed mm/s	導程 Lead 5													300													
	導程 Lead 10													600													
	導程 Lead 20													1200	533	500	450	400	350	300	250	200					
	導程 Lead 32													1920	1067	1000	900	800	700	600	500	400					

BR 馬達右折 Motor Right Side



CAD圖面可至www.toyorobot.com下載

Please download the CAD file from TOYO's website : www.toyorobot.com

單位 Unit : mm

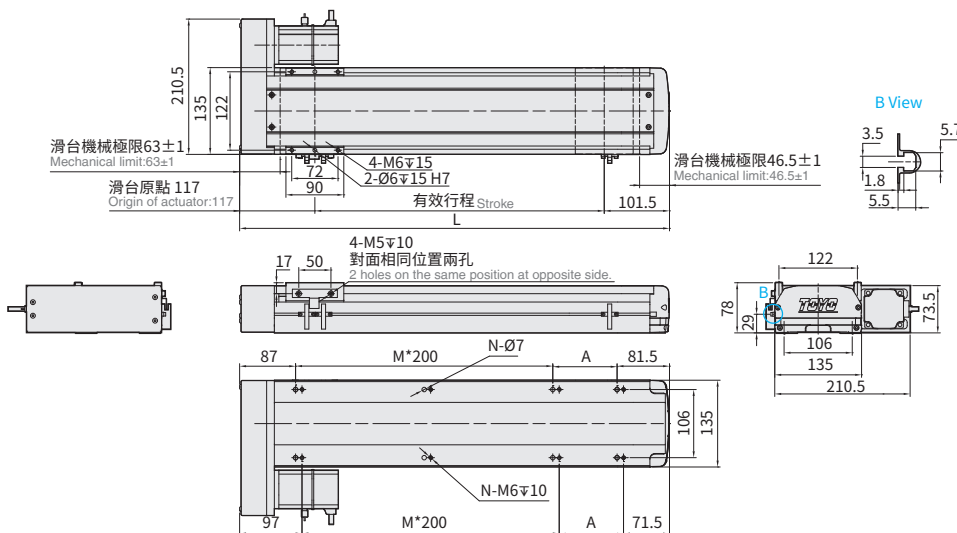

有效行程 Stroke	50	100	150	200	250	300	350	400	450	500	550	600	650	700	750	800	850	900	950	1000	1050						
極限行程 Limit Stroke (± 1)	69	119	169	219	269	319	369	419	469	519	569	619	669	719	769	819	869	919	969	1019	1069						
L	268.5	318.5	368.5	418.5	468.5	518.5	568.5	618.5	668.5	718.5	768.5	818.5	868.5	918.5	968.5	1018.5	1068.5	1118.5	1168.5	1218.5	1268.5						
A	100	150	200	50	100	150	200	50	100	150	200	50	100	150	200	50	100	150	200	50	100						
M	0	0	0	1	1	1	1	2	2	2	2	3	3	3	3	4	4	4	4	5	5						
N	4	4	4	6	6	6	6	8	8	8	8	10	10	10	10	12	12	12	12	14	14						
KG	7.94	8.5	9.06	9.62	10.18	10.74	11.3	11.86	12.42	12.98	13.54	14.1	14.66	15.22	15.78	16.34	16.9	17.46	18.02	18.58	19.14						
線速度 Linear Speed mm/s	導程 Lead 5													300													
	導程 Lead 10													600													
	導程 Lead 20													1200	533	500	450	400	350	300	250	200					
	導程 Lead 32													1920	1067	1000	900	800	700	600	500	400					

ETH Series

ETH13

ETH14

ETH17

ETH22

ETH17M

ETH22M

ETH13 單軸 /1-axis

BM 馬達下折 Motor Bottom Side



CAD圖面可至www.toyorobot.com下載
Please download the CAD file from TOYO's website : www.toyorobot.com

單位 Unit : mm

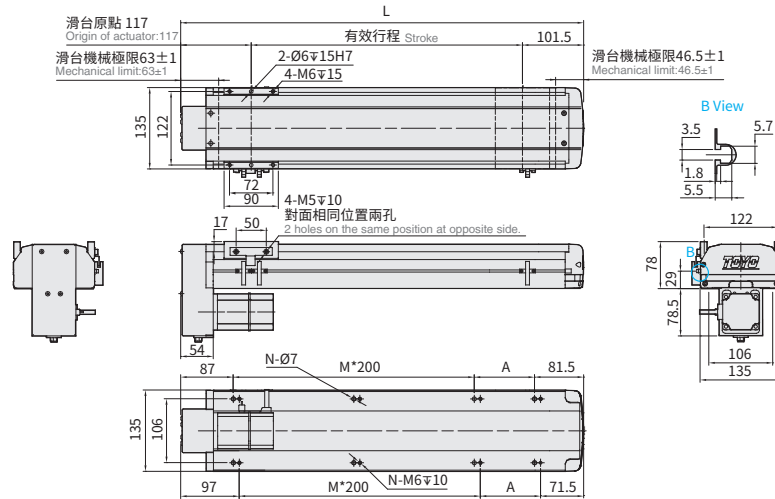

有效行程 Stroke	50	100	150	200	250	300	350	400	450	500	550	600	650	700	750	800	850	900	950	1000	1050
極限行程 Limit Stroke (±1)	69	119	169	219	269	319	369	419	469	519	569	619	669	719	769	819	869	919	969	1019	1069
L	268.5	318.5	368.5	418.5	468.5	518.5	568.5	618.5	668.5	718.5	768.5	818.5	868.5	918.5	968.5	1018.5	1068.5	1118.5	1168.5	1218.5	1268.5
A	100	150	200	50	100	150	200	50	100	150	200	50	100	150	200	50	100	150	200	50	100
M	0	0	0	1	1	1	1	2	2	2	2	3	3	3	3	4	4	4	4	5	5
N	4	4	4	6	6	6	6	8	8	8	8	10	10	10	10	12	12	12	12	14	14
KG	7.94	8.5	9.06	9.62	10.18	10.74	11.3	11.86	12.42	12.98	13.54	14.1	14.66	15.22	15.78	16.34	16.9	17.46	18.02	18.58	19.14
線速度 Linear Speed mm/s	導程 Lead 5													267	250	225	200	175	150	125	100
	導程 Lead 10													533	500	450	400	350	300	250	200
	導程 Lead 20													1067	1000	900	800	700	600	500	400
	導程 Lead 32													1707	1600	1440	1280	1120	960	800	640

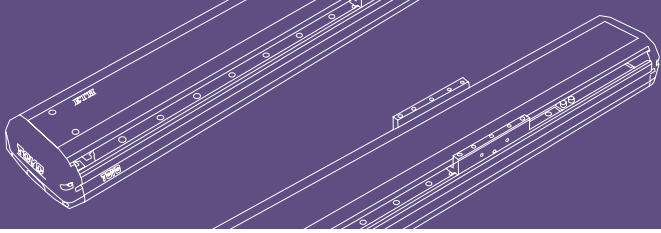

免費服務專線：大陸 400-875-0009 台灣 0800-800-893
Toll-Free Number China Taiwan

應用例
Application

一般 / 螺桿仕様
ETH

一般 / 皮帶仕様
ETB / M

無塵 / 螺桿仕様
GCH / ECH

無塵 / 皮帶仕様
ECB

直交連結
XYGT / XTH / XYTB

參考資料
Reference

Memo

ETH Series

ETH13

ETH14

ETH17

ETH22

ETH17M

ETH22M

ETH13 單軸 /1-axis

▶ 螺桿驅動
Ball Screw Drive

精度
±0.005 mm



- 最大行程 1050mm
Maximum Stroke
- 最高速度 1920mm/s
Maximum Speed
- 馬達容量 400W
Motor Output
- 滾珠螺桿 ø16mm
Ball Screw
- 直線滑軌 15X12.5-2 支
Linear Guide

型號表示方式 Ordering Method

ETH13 - L5 - 50 - BC - M40B - C4N5 - 參照右頁 - 0001

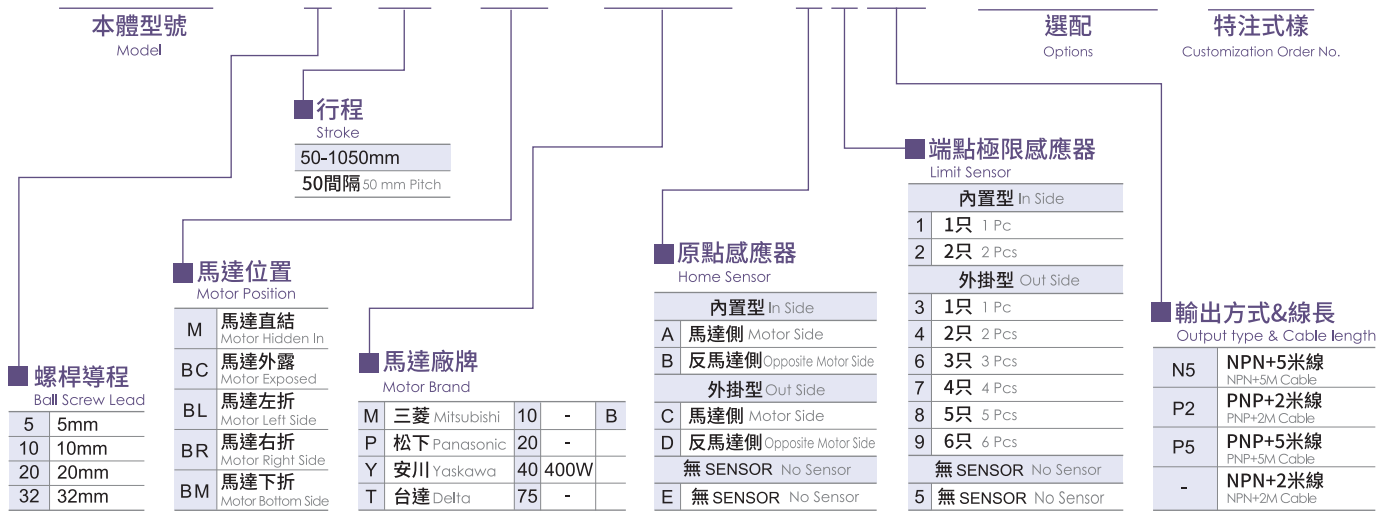

*若無煞車則不表示。*If No Brake, No Description.

*感應器由客戶自行安裝,圖面最多示意為3只

*The sensors are installed by customers themselves, and the diagram shows a maximum of 3 sensors.

基本仕様 Specification

性能	位置重複精度 Repeatability	mm	±0.005				
	螺桿導程 Lead	mm	5	10	20	32	
	最高轉速 Maximum Rotating speed	rpm	3600	3600	3600	3600	
	最高速度 Maximum linear speed ※1	mm/s	300	600	1200	1920	
	最大可搬重量 Maximum Payload	水平使用 Horizontal	kg	70	47	24	13
		垂直使用 Vertical	kg	17	12	6	-
	定格推力 Rated Thrust	N	1388	694	433	347	
	標準行程 Stroke (increments)	mm	50-1050mm/50 間隔 (50 increments)				
部品	AC 伺服馬達容量 AC Servo Motor Output	W	400				
	滾珠螺桿外徑 Ball Screw Ø	mm	C7Ø16				
	高剛性直線滑軌 High Rigidity Linear Guide	mm	W15XH12.5				
	連軸器 Coupling	mm	10X14				
	原點感應器 Home Sensor	外掛 Outside		T62N2 (NPN+2 米線) (NPN+2M Cable)			
		內置 Built-In		T64N2 (NPN+2 米線) (NPN+2M Cable)			

※1 長行程時，會產生螺桿偏擺，需將速度調降 (線速度請參閱尺寸圖下方表格)

During in a long stroke, it causes ballscrew deflection, the speed must reduce. (Please refer to the linear velocity from the data sheet below the dimension graph.)

容許負載力距表 Allowable Overhang

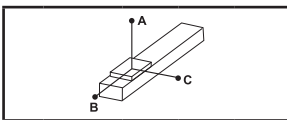

(單位 Unit : mm)

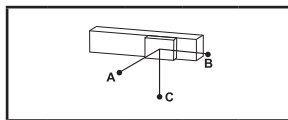

(單位 Unit : mm)

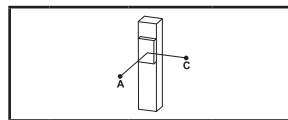

(單位 Unit : mm)

水平安裝 Horizontal Installation		A	B	C
導程 5 Lead	40kg	647	62	211
	55kg	453	42	145
	70kg	342	31	107
導程 10 Lead	25kg	470	91	245
	35kg	327	62	168
	47kg	235	44	120
導程 20 Lead	6kg	772	308	546
	15kg	299	117	210
	24kg	181	70	126
導程 32 Lead	3kg	660	422	528
	7kg	277	175	221
	13kg	145	90	115

壁掛安裝 Wall Installation		A	B	C
導程 5 Lead	40kg	211	62	647
	55kg	145	42	453
	70kg	107	31	342
導程 10 Lead	25kg	245	91	470
	35kg	168	62	327
	47kg	120	44	235
導程 20 Lead	6kg	546	308	772
	15kg	210	117	299
	24kg	126	70	181
導程 32 Lead	3kg	528	422	660
	7kg	221	175	277
	13kg	115	90	145

垂直安裝 Vertical Installation		A	C
導程 5 Lead	5kg	567	567
	11kg	258	258
	17kg	167	167
導程 10 Lead	4kg	616	616
	8kg	308	308
	12kg	205	205
導程 20 Lead	2kg	868	868
	3kg	578	578
	6kg	289	289

靜額定扭矩 Static Loading Moment

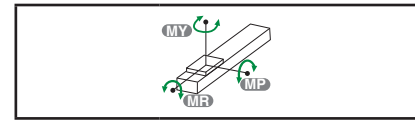

(單位 Unit : N.m)

MY	174
MP	175
MR	153

* 力矩表所表示的數據，代表荷重的重心位置於單一方向容許懸出的長度。
 The data represented by the moment table is the center of gravity of the load. The length of the overhang is allowed in a single direction.
 * 符合型錄規範的正常使用下，保證壽命為 10,000 公里。
 Operation life is 10,000km when the product is using under the specified conditions.
 * 倒吊使用無法套用標準規範，如有需求請洽詢我業務。
 Data information is not for ceiling-mount inverse use. Contact us for the details if you want to apply ceiling-mount inverse usage.
 * 壽命及力矩是以馬達加速減速設定 0.2 秒計算。
 The life and torque are calculated by setting the motor acceleration and deceleration for 0.2 seconds.

選配 Options

NL		P		EB		MM		CMK					
外拉式注油嘴位置 External oil injection nozzle position		標準 PIN 孔 Standard PIN hole		外觀黑色處理 Outer layer is treated with black oxide		指定馬達出線方向 Selectable Cable Leading Direction		馬達傳動配件追加鍵槽 Additional keyway for motor drive parts					
代號 Code	說明 Instructions	需參照 Refer to	代號 Code	說明 Instructions	需參照 Refer to	代號 Code	說明 Instructions	代號 Code	說明 Instructions	馬達位置 Motor Position	出貨型式 Shipment type	需參照 Refer to	
NL	滑座右側 On The Right of The Slider	P.675 ~ P.676	P	標準 PIN 孔 Standard PIN hole	P.677	EB	黑色 Black	本體 Main Body	MW	朝上 Upper side	BC/M	鍵槽式聯軸器 Keyway Coupling	P.681 ~ P.682
NR	滑座右側 On The Right of The Slider		EB	原色 Original color		不銹鋼 板材 Stainless steel plate 螺絲 Screw	MM	朝下 Bottom side	BL/BR/BM	鍵槽式皮帶輪 Keyway Belt Pulley			
NRL	滑座雙邊注油 Slide both sides for oil injection		SKY	雙邊 Double		BC/M	鍵槽式聯軸器 Keyway Coupling	BL/BR/BM	不適用 Not Applicable	無聯軸器 (請自行購買安裝) Without Coupling (Please purchase and install by yourself)			
						MR	朝右 Right side	BL/BR/BM	不適用 Not Applicable				

M 馬達直結 Motor Hidden In



CAD圖面可至www.toyorobot.com下載
Please download the CAD file from TOYO's website : www.toyorobot.com

單位 Unit : mm

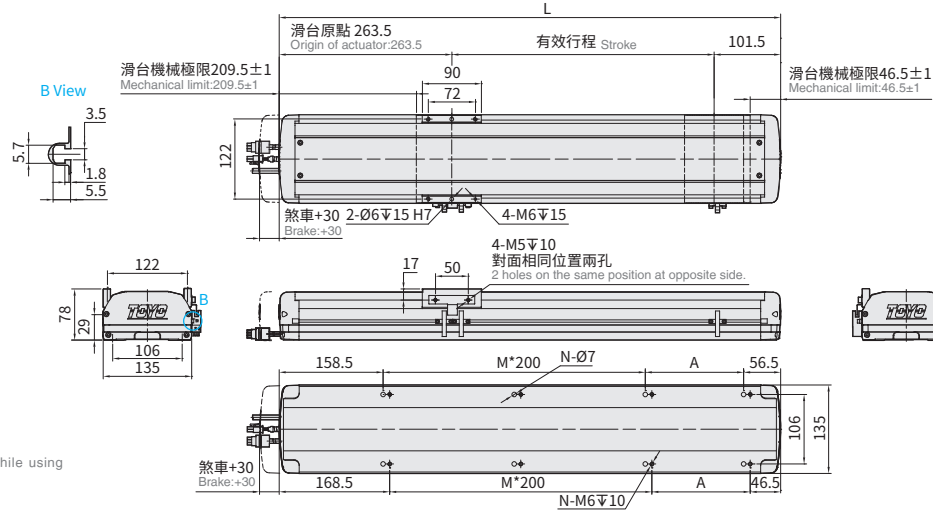

※ 台達 400W 時，煞車 +40 -
Length will be added 40mm while using
Delta 400w motor.

有效行程 Stroke	50	100	150	200	250	300	350	400	450	500	550	600	650	700	750	800	850	900	950	1000	1050		
極限行程 Limit Stroke (±1)	69	119	169	219	269	319	369	419	469	519	569	619	669	719	769	819	869	919	969	1019	1069		
L	415	465	515	565	615	665	715	765	815	865	915	965	1015	1065	1115	1165	1215	1265	1315	1365	1415		
A	200	50	100	150	200	50	100	150	200	50	100	150	200	50	100	150	200	50	100	150	200		
M	0	1	1	1	1	2	2	2	2	3	3	3	3	4	4	4	4	5	5	5	5		
N	4	6	6	6	6	8	8	8	8	10	10	10	10	12	12	12	12	14	14	14	14		
KG	8.3	8.86	9.42	9.98	10.54	11.1	11.66	12.22	12.78	13.34	13.9	14.46	15.02	15.58	16.14	16.7	17.26	17.82	18.38	18.94	19.5		
線速度 Linear Speed mm/s	導程 Lead 5														267	250	225	200	175	150	125	100	
	導程 Lead 10														600								
	導程 Lead 20														533	500	450	400	350	300	250	200	
	導程 Lead 32														1067	1000	900	800	700	600	500	400	

BC 馬達外露 Motor Exposed



CAD圖面可至www.toyorobot.com下載
Please download the CAD file from TOYO's website : www.toyorobot.com

單位 Unit : mm

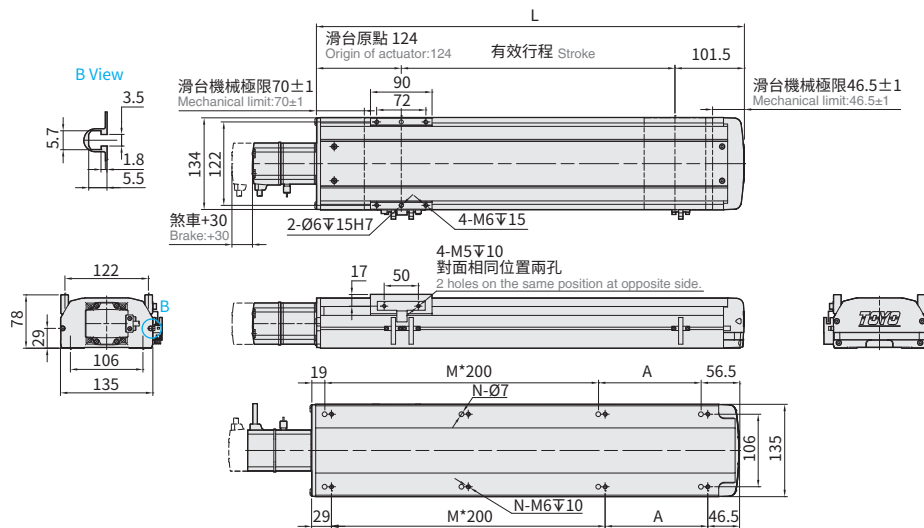

有效行程 Stroke	50	100	150	200	250	300	350	400	450	500	550	600	650	700	750	800	850	900	950	1000	1050		
極限行程 Limit Stroke (±1)	69	119	169	219	269	319	369	419	469	519	569	619	669	719	769	819	869	919	969	1019	1069		
L	275.5	325.5	375.5	425.5	475.5	525.5	575.5	625.5	675.5	725.5	775.5	825.5	875.5	925.5	975.5	1025.5	1075.5	1125.5	1175.5	1225.5	1275.5		
A	200	50	100	150	200	50	100	150	200	50	100	150	200	50	100	150	200	50	100	150	200		
M	0	1	1	1	1	2	2	2	2	3	3	3	3	4	4	4	4	5	5	5	5		
N	4	6	6	6	6	8	8	8	8	10	10	10	10	12	12	12	12	14	14	14	14		
KG	7.4	7.96	8.52	9.08	9.64	10.2	10.76	11.32	11.88	12.44	13	13.56	14.12	14.68	15.24	15.8	16.36	16.92	17.48	18.04	18.6		
線速度 Linear Speed mm/s	導程 Lead 5														267	250	225	200	175	150	125	100	
	導程 Lead 10														600								
	導程 Lead 20														533	500	450	400	350	300	250	200	
	導程 Lead 32														1067	1000	900	800	700	600	500	400	

ETH13 單軸 /1-axis

BM 馬達下折 Motor Bottom Side



CAD圖面可至www.toyorobot.com下載
Please download the CAD file from TOYO's website : www.toyorobot.com

單位 Unit : mm

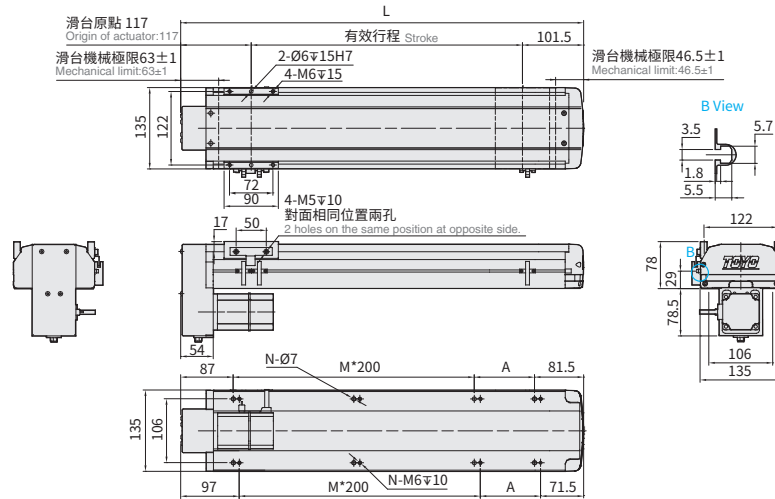

有效行程 Stroke	50	100	150	200	250	300	350	400	450	500	550	600	650	700	750	800	850	900	950	1000	1050
極限行程 Limit Stroke (± 1)	69	119	169	219	269	319	369	419	469	519	569	619	669	719	769	819	869	919	969	1019	1069
L	268.5	318.5	368.5	418.5	468.5	518.5	568.5	618.5	668.5	718.5	768.5	818.5	868.5	918.5	968.5	1018.5	1068.5	1118.5	1168.5	1218.5	1268.5
A	100	150	200	50	100	150	200	50	100	150	200	50	100	150	200	50	100	150	200	50	100
M	0	0	0	1	1	1	1	2	2	2	2	3	3	3	3	4	4	4	4	5	5
N	4	4	4	6	6	6	6	8	8	8	8	10	10	10	10	12	12	12	12	14	14
KG	7.94	8.5	9.06	9.62	10.18	10.74	11.3	11.86	12.42	12.98	13.54	14.1	14.66	15.22	15.78	16.34	16.9	17.46	18.02	18.58	19.14
線速度 Linear Speed mm/s	導程 Lead 5													267	250	225	200	175	150	125	100
	導程 Lead 10													533	500	450	400	350	300	250	200
	導程 Lead 20													1067	1000	900	800	700	600	500	400
	導程 Lead 32													1707	1600	1440	1280	1120	960	800	640

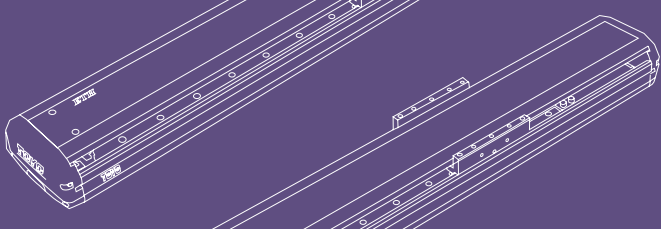

免費服務專線：大陸 400-875-0009 台灣 0800-800-893
Toll-Free Number China Taiwan

應用例
Application

一般 / 螺桿仕様
ETH

一般 / 皮帶仕様
ETB / M

無塵 / 螺桿仕様
GCH / ECH

無塵 / 皮帶仕様
ECB

直交連結
XYGT / XTH / XYTB

參考資料
Reference

Memo

ETH Series

ETH13

ETH14

ETH17

ETH22

ETH17M

ETH22M

ETH14 單軸 /1-axis

▶ 螺桿驅動
Ball Screw Drive



精度
±0.005 mm

- 最大行程 1050mm
Maximum Stroke
- 最高速度 1920mm/s
Maximum Speed
- 馬達容量 200W
Motor Output
- 滾珠螺桿 ø16mm
Ball Screw
- 直線滑軌 15X12.5-2 支
Linear Guide

型號表示方式 Ordering Method

ETH14 - L5 - 50 - M - M20B - C4N5 - 參照右頁
Refer to the right page. - 0001

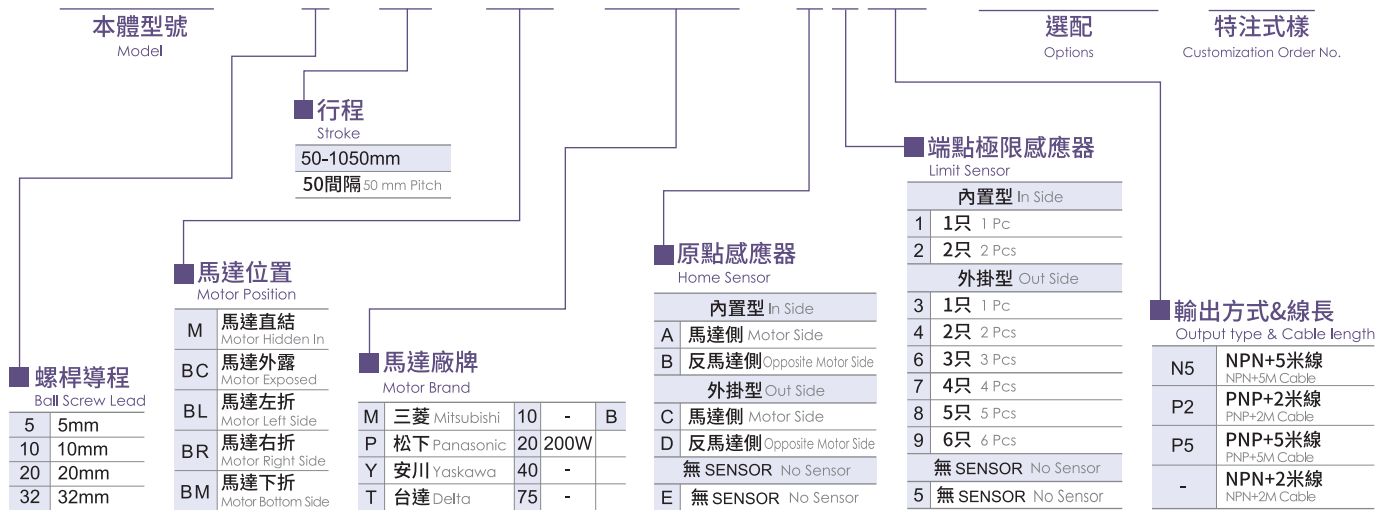

*若無煞車則不表示。†† No Brake, No Description.

*感應器由客戶自行安裝,圖面最多示意為3只

†The sensors are installed by customers themselves, and the diagram shows a maximum of 3 sensors.

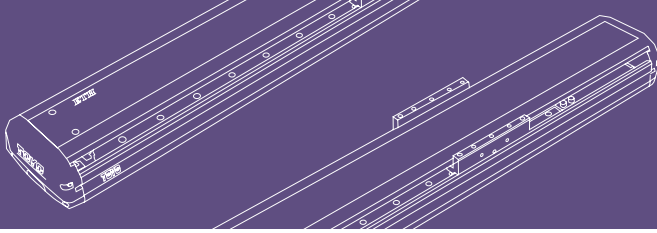

免費服務專線：大陸 400-875-0009 台灣 0800-800-893
 Toll-Free Number China Taiwan

應用例
Application

一般 / 螺桿仕様
ETH

一般 / 皮帶仕様
ETB / M

無塵 / 螺桿仕様
GCH / ECH

無塵 / 皮帶仕様
ECB

直交連結
XYGT / XYTH / XYTB

參考資料
Reference

基本仕様 Specification

性能	位置重複精度 Repeatability	mm	±0.005				
	螺桿導程 Lead	mm	5	10	20	32	
	最高轉速 Maximum Rotating speed	rpm	3600	3600	3600	3600	
	最高速度 Maximum linear speed ※1	mm/s	300	600	1200	1920	
	最大可搬重量 Maximum Payload	水平使用 Horizontal	kg	95	75	35	15
		垂直使用 Vertical	kg	27	18	7	-
	定格推力 Rated Thrust	N	683	341	174	107	
部品	標準行程 Stroke (increments)	mm	50-1050mm/50 間隔 (50 increments)				
	AC 伺服馬達容量 AC Servo Motor Output	W	200				
	滾珠螺桿外徑 Ball Screw Ø	mm	C7Ø16				
	高剛性直線滑軌 High Rigidity Linear Guide	mm	W15XH12.5				
	連軸器 Coupling	mm	10X14/11 ※2				
	原點感應器 Home Sensor	外掛 Outside		T62N2 (NPN+2 米線) (NPN+2M Cable)			
		內置 Built-In		T64N2 (NPN+2 米線) (NPN+2M Cable)			

※1 長行程時，會產生螺桿偏擺，需將速度調降 (線速度請參閱尺寸圖下方表格)
 During in a long stroke, it causes ballscrew deflection, the speed must reduce. (Please refer to the linear velocity from the data sheet below the dimension graph.)
 ※2 使用 Panasonic 200W 馬達時，馬達軸心為 Ø11；其他廠牌，馬達軸心為 Ø14。
 Motor (200W) Shaft Diameter: Panasonic: 11mm; Other: 14mm.

容許負載力距表 Allowable Overhang

(單位 Unit : mm)				(單位 Unit : mm)				(單位 Unit : mm)			
水平安裝 Horizontal Installation				壁掛安裝 Wall Installation				垂直安裝 Vertical Installation			
	A	B	C		A	B	C		A	C	
導程 5 Lead	60kg	2489	237	225	60kg	225	237	2489	15kg	1102	1102
	80kg	1799	168	159	80kg	159	168	1799	22kg	751	751
	95kg	1472	135	128	95kg	128	135	1472	27kg	612	612
導程 10 Lead	30kg	2303	450	406	30kg	406	450	2303	10kg	1435	1435
	50kg	1329	254	229	50kg	229	254	1329	14kg	1025	1025
	75kg	841	150	141	75kg	141	150	841	18kg	797	797
導程 20 Lead	10kg	2687	1069	859	10kg	859	1069	2687	3kg	3371	3371
	22kg	1185	464	374	22kg	374	464	1185	5kg	2023	2023
	35kg	720	277	223	35kg	223	277	720	7kg	1445	1445
導程 32 Lead	5kg	2300	1470	1026	5kg	1026	1470	2300			
	10kg	1129	715	500	10kg	500	715	1129			
	15kg	739	463	325	15kg	325	463	739			

靜額定扭矩 Static Loading Moment

(單位 Unit : N.m)		
MY		551
MP		552
MR		485

* 力矩表所表示的數據，代表荷重的重心位置於單一方向容許懸出的長度。
 The data represented by the moment table is the center of gravity of the load. The length of the overhang is allowed in a single direction.
 * 符合型錄規範的正常使用下，保證壽命為 10000 公里。
 Operation life is 10,000km when the product is using under the specified conditions.
 * 倒吊使用無法套用標準規範，如有需求請洽詢我司業務。
 Data information is not for ceiling-mount inverse use. Contact us for the details if you want to apply ceiling-mount inverse usage.
 * 壽命及力矩是以馬達加減速設定 0.2 秒計算。
 The life and torque are calculated by setting the motor acceleration and deceleration for 0.2 seconds.

選配 Options

NL			P			EB			MM			CMK			
外拉式注油嘴位置 External oil injection nozzle position			標準 PIN 孔 Standard PIN hole			外觀黑色處理 Outer layer is treated with black oxide			指定馬達出線方向 Selectable Cable Leading Direction			馬達傳動配件追加鍵槽 Additional keyway for motor drive parts			
代號 Code	說明 Instructions	需參照 Refer to	代號 Code	說明 Instructions	需參照 Refer to	代號 Code	說明 Instructions	需參照 Refer to	代號 Code	說明 Instructions	需參照 Refer to	代號 Code	說明 Instructions	需參照 Refer to	
NL	滑座右側 On The Right of The Slider	P.675 ~ P.676	P	標準 PIN 孔 Standard PIN hole	P.677	EB	黑色 Black	本體 Main Body	MW	朝上 Upper side	P.679 ~ P.680	CMK	單邊 (限定馬達側) Single (Limited to the motor side)	BC/M	鍵槽式聯軸器 Keyway Coupling
NR	滑座右側 On The Right of The Slider		EB	原色 Original color	不銹鋼 板材 Stainless steel plate	MM	朝下 Bottom side	CMK	BL/BR/BM	鍵槽式皮帶輪 Keyway Belt Pulley					
NRL	滑座雙邊注油 Slide both sides for oil injection		EB	原色 Original color	螺絲 Screw	ML	朝左 Left side	SKY	雙邊 Double	BC/M		鍵槽式聯軸器 Keyway Coupling			
		MR	朝右 Right side	不適用 Not Applicable	SKN	雙邊 Double	BC/M	無聯軸器 (請自行購買安裝) Without Coupling (Please purchase and install by yourself)	BL/BR/BM	不適用 Not Applicable					

ETH Series

- ETH13
- ETH14
- ETH17
- ETH22
- ETH17M
- ETH22M

M 馬達直結 Motor Hidden In



• CAD圖面可至www.toyorobot.com下載 •
Please download the CAD file from TOYO's website : www.toyorobot.com

單位 Unit : mm

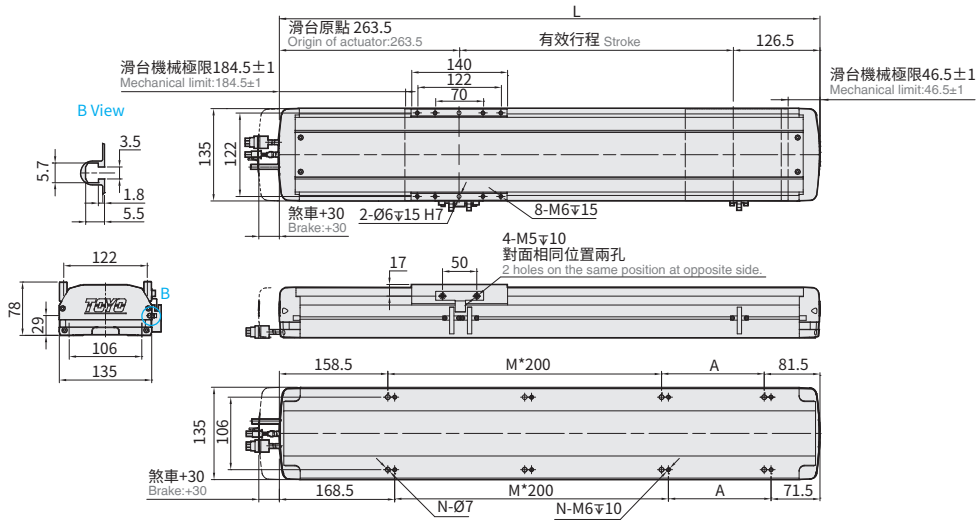

有效行程 Stroke	50	100	150	200	250	300	350	400	450	500	550	600	650	700	750	800	850	900	950	1000	1050								
極限行程 Limit Stroke (±1)	69	119	169	219	269	319	369	419	469	519	569	619	669	719	769	819	869	919	969	1019	1069								
L	440	490	540	590	640	690	740	790	840	890	940	990	1040	1090	1140	1190	1240	1290	1340	1390	1440								
A	200	50	100	150	200	50	100	150	200	50	100	150	200	50	100	150	200	50	100	150	200								
M	0	1	1	1	1	2	2	2	2	3	3	3	3	4	4	4	4	5	5	5	5								
N	4	6	6	6	6	8	8	8	8	10	10	10	10	12	12	12	12	14	14	14	14								
KG	9.5	10.06	10.62	11.18	11.74	12.3	12.86	13.42	13.98	14.54	15.1	15.66	16.22	16.78	17.34	17.9	18.46	19.02	19.58	20.14	20.7								
線速度 Linear Speed mm/s	導程 Lead 5											275		250		225		200		175		150		125		100			
	導程 Lead 10											600		550		500		450		400		350		300		250		200	
	導程 Lead 20											1200		1100		1000		900		800		700		600		500		400	
	導程 Lead 32											1920		1760		1600		1440		1280		1120		960		800		640	

BC 馬達外露 Motor Exposed



• CAD圖面可至www.toyorobot.com下載 •
Please download the CAD file from TOYO's website : www.toyorobot.com

單位 Unit : mm

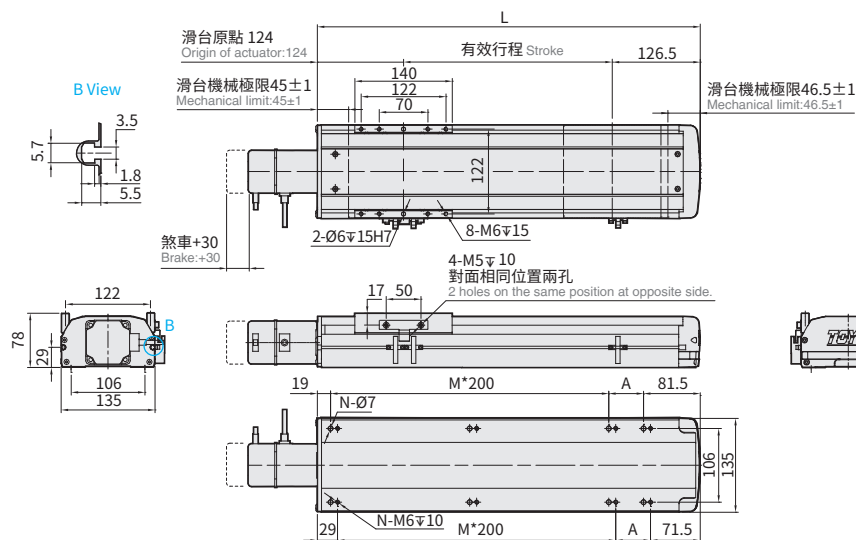

有效行程 Stroke	50	100	150	200	250	300	350	400	450	500	550	600	650	700	750	800	850	900	950	1000	1050								
極限行程 Limit Stroke (±1)	69	119	169	219	269	319	369	419	469	519	569	619	669	719	769	819	869	919	969	1019	1069								
L	300.5	350.5	400.5	450.5	500.5	550.5	600.5	650.5	700.5	750.5	800.5	850.5	900.5	950.5	1000.5	1050.5	1100.5	1150.5	1200.5	1250.5	1300.5								
A	200	50	100	150	200	50	100	150	200	50	100	150	200	50	100	150	200	50	100	150	200								
M	0	1	1	1	1	2	2	2	2	3	3	3	3	4	4	4	4	5	5	5	5								
N	4	6	6	6	6	8	8	8	8	10	10	10	10	12	12	12	12	14	14	14	14								
KG	8.75	9.3	9.85	10.4	10.95	11.5	12.05	12.6	13.15	13.7	14.25	14.8	15.35	15.9	16.45	17	17.55	18.1	18.65	19.2	19.75								
線速度 Linear Speed mm/s	導程 Lead 5											275		250		225		200		175		150		125		100			
	導程 Lead 10											600		550		500		450		400		350		300		250		200	
	導程 Lead 20											1200		1100		1000		900		800		700		600		500		400	
	導程 Lead 32											1920		1760		1600		1440		1280		1120		960		800		640	

BL 馬達左折 Motor Left Side



CAD圖面可至www.toyorobot.com下載

Please download the CAD file from TOYO's website : www.toyorobot.com

單位 Unit : mm

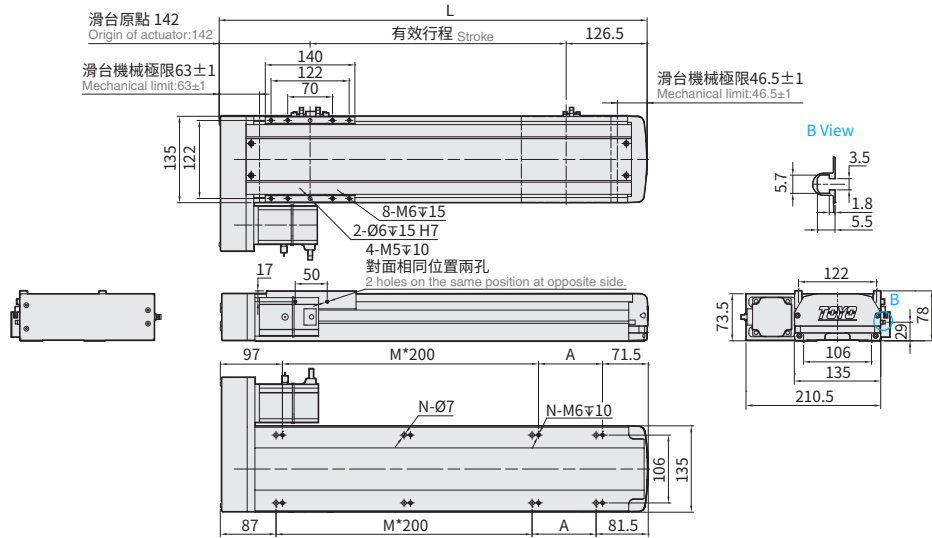

有效行程 Stroke	50	100	150	200	250	300	350	400	450	500	550	600	650	700	750	800	850	900	950	1000	1050	
極限行程 Limit Stroke (±1)	69	119	169	219	269	319	369	419	469	519	569	619	669	719	769	819	869	919	969	1019	1069	
L	318.5	368.5	418.5	468.5	518.5	568.5	618.5	668.5	718.5	768.5	818.5	868.5	918.5	968.5	1018.5	1068.5	1118.5	1168.5	1218.5	1268.5	1318.5	
A	150	200	50	100	150	200	50	100	150	200	50	100	150	200	50	100	150	200	50	100	150	
M	0	0	1	1	1	1	2	2	2	2	3	3	3	3	4	4	4	4	5	5	5	
N	4	4	6	6	6	6	8	8	8	8	10	10	10	10	12	12	12	12	14	14	14	
KG	9.4	9.94	10.48	11.02	11.56	12.1	12.64	13.18	13.72	14.26	14.8	15.34	15.88	16.42	16.96	17.5	18.04	18.58	19.12	19.66	20.2	
線速度 Linear Speed mm/s	導程 Lead 5	300										275	250	225	200	175	150	125	100			
	導程 Lead 10	600										550	500	450	400	350	300	250	200			
	導程 Lead 20	1200										1100	1000	900	800	700	600	500	400			
	導程 Lead 32	1920										1760	1600	1440	1280	1120	960	800	640			

BR 馬達右折 Motor Right Side



CAD圖面可至www.toyorobot.com下載

Please download the CAD file from TOYO's website : www.toyorobot.com

單位 Unit : mm

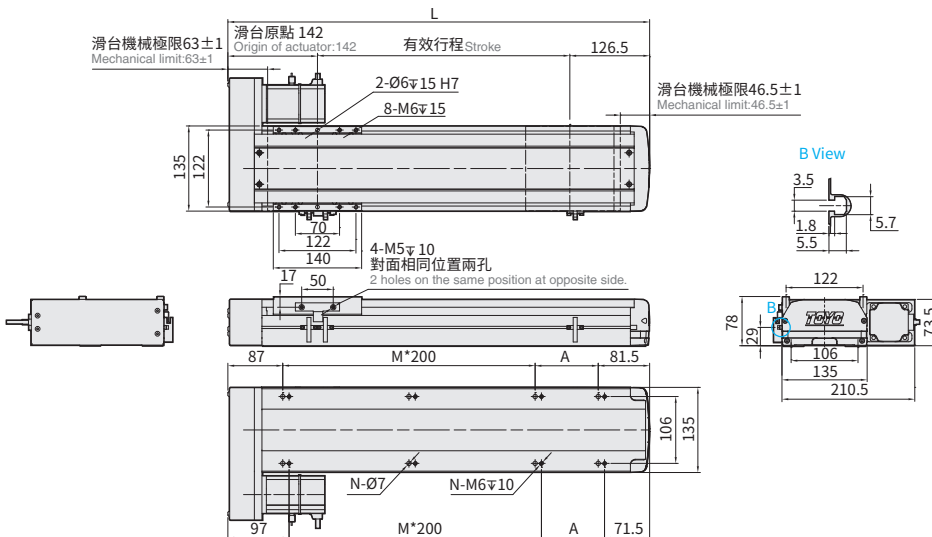

有效行程 Stroke	50	100	150	200	250	300	350	400	450	500	550	600	650	700	750	800	850	900	950	1000	1050	
極限行程 Limit Stroke (±1)	69	119	169	219	269	319	369	419	469	519	569	619	669	719	769	819	869	919	969	1019	1069	
L	318.5	368.5	418.5	468.5	518.5	568.5	618.5	668.5	718.5	768.5	818.5	868.5	918.5	968.5	1018.5	1068.5	1118.5	1168.5	1218.5	1268.5	1318.5	
A	150	200	50	100	150	200	50	100	150	200	50	100	150	200	50	100	150	200	50	100	150	
M	0	0	1	1	1	1	2	2	2	2	3	3	3	3	4	4	4	4	5	5	5	
N	4	4	6	6	6	6	8	8	8	8	10	10	10	10	12	12	12	12	14	14	14	
KG	9.4	9.94	10.48	11.02	11.56	12.1	12.64	13.18	13.72	14.26	14.8	15.34	15.88	16.42	16.96	17.5	18.04	18.58	19.12	19.66	20.2	
線速度 Linear Speed mm/s	導程 Lead 5	300										275	250	225	200	175	150	125	100			
	導程 Lead 10	600										550	500	450	400	350	300	250	200			
	導程 Lead 20	1200										1100	1000	900	800	700	600	500	400			
	導程 Lead 32	1920										1760	1600	1440	1280	1120	960	800	640			

ETH Series

ETH13

ETH14

ETH17

ETH22

ETH17M

ETH22M

ETH14 單軸 /1-axis

BM 馬達下折 Motor Bottom Side



CAD圖面可至www.toyorobot.com下載
Please download the CAD file from TOYO's website : www.toyorobot.com

單位 Unit : mm

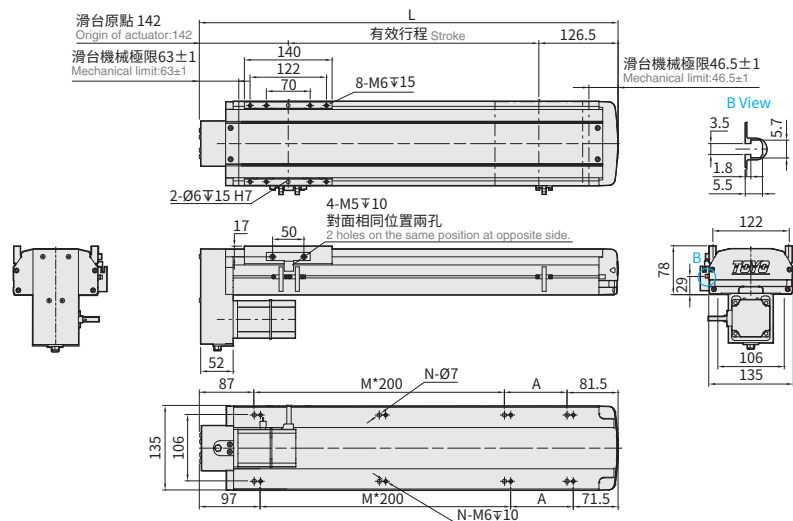

有效行程 Stroke	50	100	150	200	250	300	350	400	450	500	550	600	650	700	750	800	850	900	950	1000	1050		
極限行程 Limit Stroke (±1)	69	119	169	219	269	319	369	419	469	519	569	619	669	719	769	819	869	919	969	1019	1069		
L	318.5	368.5	418.5	468.5	518.5	568.5	618.5	668.5	718.5	768.5	818.5	868.5	918.5	968.5	1018.5	1068.5	1118.5	1168.5	1218.5	1268.5	1318.5		
A	150	200	50	100	150	200	50	100	150	200	50	100	150	200	50	100	150	200	50	100	150		
M	0	0	1	1	1	1	2	2	2	2	3	3	3	3	4	4	4	4	5	5	5		
N	4	4	6	6	6	6	8	8	8	8	10	10	10	10	12	12	12	12	14	14	14		
KG	9.4	9.94	10.48	11.02	11.56	12.1	12.64	13.18	13.72	14.26	14.8	15.34	15.88	16.42	16.96	17.5	18.04	18.58	19.12	19.66	20.2		
線速度 Linear Speed mm/s	導程 Lead 5												275	250	225	200	175	150	125	100			
	導程 Lead 10												550	500	450	400	350	300	250	200			
	導程 Lead 20												1100	1000	900	800	700	600	500	400			
	導程 Lead 32												1760	1600	1440	1280	1120	960	800	640			

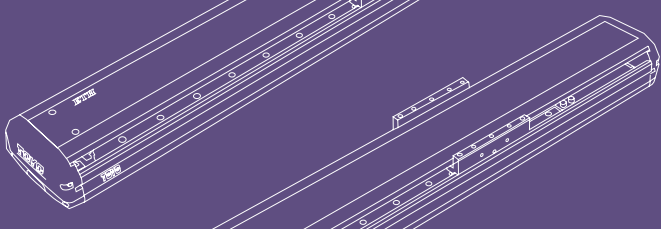

免費服務專線：大陸 400-875-0009 台灣 0800-800-893
Toll-Free Number China Taiwan

應用例
Application

一般 / 螺桿仕様
ETH

一般 / 皮帶仕様
ETB / M

無塵 / 螺桿仕様
GCH / ECH

無塵 / 皮帶仕様
ECB

直交連結
XYGT / XTH / XYTB

參考資料
Reference

Memo

ETH Series

ETH13

ETH14

ETH17

ETH22

ETH17M

ETH22M

ETH14 單軸 /1-axis

▶ 螺桿驅動
Ball Screw Drive



精度
±0.005 mm

- 最大行程 1050mm
Maximum Stroke
- 最高速度 1920mm/s
Maximum Speed
- 馬達容量 400W
Motor Output
- 滾珠螺桿 ø16mm
Ball Screw
- 直線滑軌 15X12.5-2 支
Linear Guide

型號表示方式 Ordering Method

ETH14 - L5 - 50 - M - M40B - C4N5 - 參照右頁 - 0001

本體型號
Model

行程
Stroke

50-1050mm
50間隔 50 mm Pitch

馬達位置
Motor Position

M	馬達直結 Motor Hidden In
BC	馬達外露 Motor Exposed
BL	馬達左折 Motor Left Side
BR	馬達右折 Motor Right Side
BM	馬達下折 Motor Bottom Side

馬達廠牌
Motor Brand

M	三菱 Mitsubishi	10	-	B
P	松下 Panasonic	20	-	
Y	安川 Yaskawa	40	400W	
T	台達 Delta	75	-	

*若無煞車則不表示。*If No Brake, No Description.

原點感應器
Home Sensor

內置型 In Side	
A	馬達側 Motor Side
B	反馬達側 Opposite Motor Side
外掛型 Out Side	
C	馬達側 Motor Side
D	反馬達側 Opposite Motor Side
無 SENSOR No Sensor	
E	無 SENSOR No Sensor

參照右頁
Refer to the right page.

選配
Options

端點極限感應器
Limit Sensor

內置型 In Side	
1	1只 1 Pc
2	2只 2 Pcs
外掛型 Out Side	
3	1只 1 Pc
4	2只 2 Pcs
6	3只 3 Pcs
7	4只 4 Pcs
8	5只 5 Pcs
9	6只 6 Pcs
無 SENSOR No Sensor	
5	無 SENSOR No Sensor

特注式樣
Customization Order No.

輸出方式&線長
Output type & Cable length

N5	NPN+5米線 NPN+5M Cable
P2	PNP+2米線 PNP+2M Cable
P5	PNP+5米線 PNP+5M Cable
-	NPN+2米線 NPN+2M Cable

*感應器由客戶自行安裝,圖面最多示意為3只

*The sensors are installed by customers themselves, and the diagram shows a maximum of 3 sensors.

基本仕様 Specification

性能	位置重複精度 Repeatability	mm	±0.005				
	螺桿導程 Lead	mm	5	10	20	32	
	最高轉速 Maximum Rotating speed	rpm	3600	3600	3600	3600	
	最高速度 Maximum linear speed *1	mm/s	300	600	1200	1920	
	最大可搬重量 Maximum Payload	水平使用 Horizontal	kg	110	88	40	30
		垂直使用 Vertical	kg	33	22	10	8
	定格推力 Rated Thrust	N	1388	694	347	218	
部品	標準行程 Stroke (increments)	mm	50-1050mm/50 間隔 (50 increments)				
	AC 伺服馬達容量 AC Servo Motor Output	W	400				
	滾珠螺桿外徑 Ball Screw Ø	mm	C7Ø16				
	高剛性直線滑軌 High Rigidity Linear Guide	mm	W15XH12.5				
	連軸器 Coupling	mm	10X14				
	原點感應器 Home Sensor	外掛 Outside		T62N2 (NPN+2 米線) (NPN+2M Cable)			
		內置 Built-In		T64N2 (NPN+2 米線) (NPN+2M Cable)			

*1 長行程時，會產生螺桿偏擺，需將速度調降 (線速度請參閱尺寸圖下方表格)

During in a long stroke, it causes ballscrew deflection, the speed must reduce. (Please refer to the linear velocity from the data sheet below the dimension graph.)

容許負載力距表 Allowable Overhang

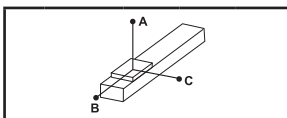

(單位 Unit : mm)

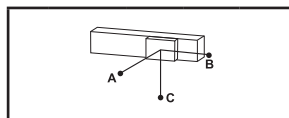

(單位 Unit : mm)

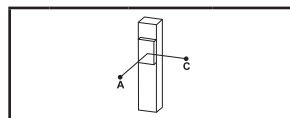

(單位 Unit : mm)

水平安裝 Horizontal Installation		A	B	C
導程 5 Lead	60kg	2489	237	225
	80kg	1799	168	159
	110kg	1233	111	105
導程 10 Lead	30kg	2303	450	406
	50kg	1329	254	229
	88kg	696	127	115
導程 20 Lead	10kg	2687	1069	859
	22kg	1185	464	374
	40kg	622	237	191
導程 32 Lead	15kg	739	463	325
	25kg	427	262	184
	30kg	349	211	149

壁掛安裝 Wall Installation		A	B	C
導程 5 Lead	60kg	225	237	2489
	80kg	159	168	1799
	110kg	105	111	1233
導程 10 Lead	30kg	406	450	2303
	50kg	229	254	1329
	88kg	115	127	696
導程 20 Lead	10kg	859	1069	2687
	22kg	374	464	1185
	40kg	191	237	622
導程 32 Lead	15kg	325	463	739
	25kg	184	262	427
	30kg	149	211	349

垂直安裝 Vertical Installation		A	C
導程 5 Lead	15kg	1102	1102
	22kg	751	751
	33kg	501	501
導程 10 Lead	10kg	1435	1435
	14kg	1025	1025
	22kg	652	652
導程 20 Lead	5kg	2023	2023
	7kg	1445	1445
	10kg	1011	1011
導程 32 Lead	3kg	2061	2061
	5kg	1236	1236
	8kg	772	772

靜額定扭矩 Static Loading Moment

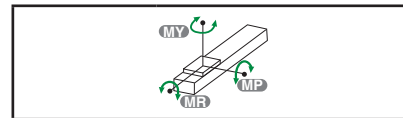

(單位 Unit : N.m)

MY	551
MP	552
MR	485

* 力矩表所表示的數據，代表荷重的重心位置於單一方向容許懸出的長度。
The data represented by the moment table is the center of gravity of the load. The length of the overhang is allowed in a single direction.
* 符合型錄規範的正常使用下，保證壽命為 10000 公里。
Operation life is 10,000km when the product is using under the specified conditions.
* 倒吊使用無法套用標準規範，如有需求請洽詢我司業務。
Data information is not for ceiling-mount inverse use. Contact us for the details if you want to apply ceiling-mount inverse usage.
* 壽命及力矩是以馬達加速減速設定 0.2 秒計算。
The life and torque are calculated by setting the motor acceleration and deceleration for 0.2 seconds.

選配 Options

NL		P		EB		MM		CMK	
外拉式注油嘴位置 External oil injection nozzle position		標準 PIN 孔 Standard PIN hole		外觀黑色處理 Outer layer is treated with black oxide		指定馬達出線方向 Selectable Cable Leading Direction		馬達傳動配件追加鍵槽 Additional keyway for motor drive parts	
代號 Code	說明 Instructions	代號 Code	說明 Instructions	代號 Code	說明 Instructions	代號 Code	說明 Instructions	代號 Code	說明 Instructions
NL	滑座右側 On The Right of The Slider	P	標準 PIN 孔 Standard PIN hole	EB	黑色 Black	MW	朝上 Upper side	CMK	單邊 (限定馬達側) Single (Limited to the motor side)
NR	滑座右側 On The Right of The Slider	P.675 ~ P.676	P.677	EB	原色 Original color	MM	朝下 Bottom side	SKY	雙邊 Double
NRL	滑座雙邊注油 Slide both sides for oil injection					ML	朝左 Left side	SKN	雙邊 Double
						MR	朝右 Right side		

ETH14 單軸 /1-axis

M 馬達直結 Motor Hidden In



• CAD圖面可至www.toyorobot.com下載 •
Please download the CAD file from TOYO's website : www.toyorobot.com

單位 Unit : mm

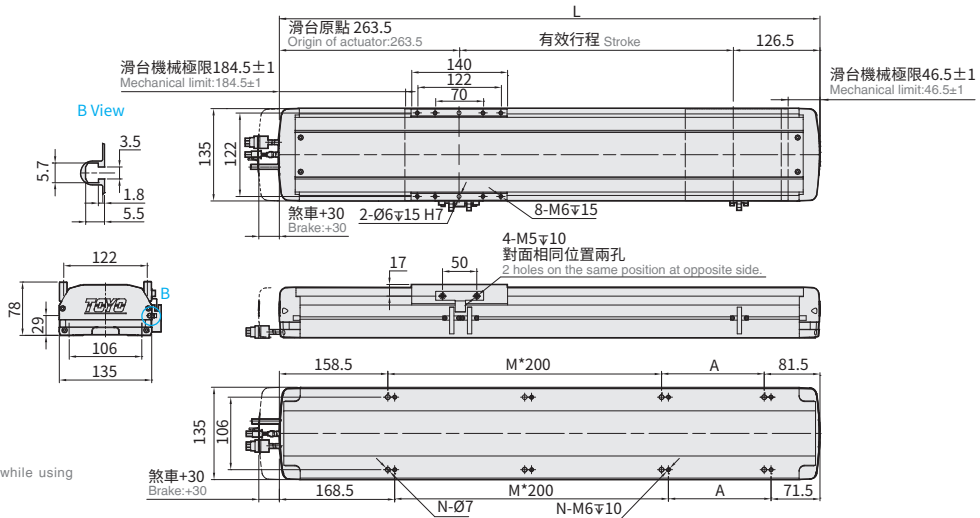

※ 台達 400W 時，煞車 +40 -
Length will be added 40mm while using
Delta 400w motor.

有效行程 Stroke	50	100	150	200	250	300	350	400	450	500	550	600	650	700	750	800	850	900	950	1000	1050
極限行程 Limit Stroke (±1)	69	119	169	219	269	319	369	419	469	519	569	619	669	719	769	819	869	919	969	1019	1069
L	440	490	540	590	640	690	740	790	840	890	940	990	1040	1090	1140	1190	1240	1290	1340	1390	1440
A	200	50	100	150	200	50	100	150	200	50	100	150	200	50	100	150	200	50	100	150	200
M	0	1	1	1	1	2	2	2	2	3	3	3	3	4	4	4	4	5	5	5	5
N	4	6	6	6	6	8	8	8	8	10	10	10	10	12	12	12	12	14	14	14	14
KG	9.5	10.06	10.62	11.18	11.74	12.3	12.86	13.42	13.98	14.54	15.1	15.66	16.22	16.78	17.34	17.9	18.46	19.02	19.58	20.14	20.7
線速度 Linear Speed mm/s	導程 Lead 5												275	250	225	200	175	150	125	100	
	導程 Lead 10												600	550	500	450	400	350	300	250	200
	導程 Lead 20												1200	1100	1000	900	800	700	600	500	400
	導程 Lead 32												1920	1760	1600	1440	1280	1120	960	800	640

BC 馬達外露 Motor Exposed



• CAD圖面可至www.toyorobot.com下載 •
Please download the CAD file from TOYO's website : www.toyorobot.com

單位 Unit : mm

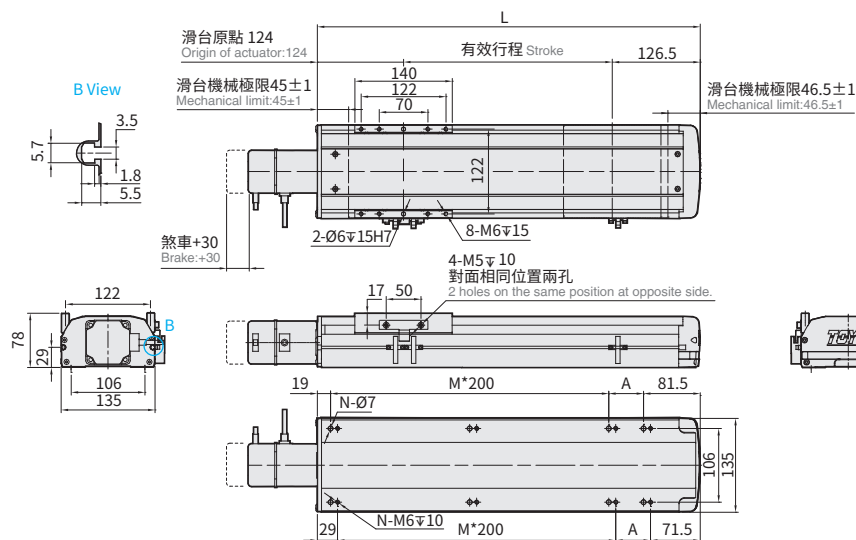

有效行程 Stroke	50	100	150	200	250	300	350	400	450	500	550	600	650	700	750	800	850	900	950	1000	1050
極限行程 Limit Stroke (±1)	69	119	169	219	269	319	369	419	469	519	569	619	669	719	769	819	869	919	969	1019	1069
L	300.5	350.5	400.5	450.5	500.5	550.5	600.5	650.5	700.5	750.5	800.5	850.5	900.5	950.5	1000.5	1050.5	1100.5	1150.5	1200.5	1250.5	1300.5
A	200	50	100	150	200	50	100	150	200	50	100	150	200	50	100	150	200	50	100	150	200
M	0	1	1	1	1	2	2	2	2	3	3	3	3	4	4	4	4	5	5	5	5
N	4	6	6	6	6	8	8	8	8	10	10	10	10	12	12	12	12	14	14	14	14
KG	8.75	9.3	9.85	10.4	10.95	11.5	12.05	12.6	13.15	13.7	14.25	14.8	15.35	15.9	16.45	17	17.55	18.1	18.65	19.2	19.75
線速度 Linear Speed mm/s	導程 Lead 5												275	250	225	200	175	150	125	100	
	導程 Lead 10												600	550	500	450	400	350	300	250	200
	導程 Lead 20												1200	1100	1000	900	800	700	600	500	400
	導程 Lead 32												1920	1760	1600	1440	1280	1120	960	800	640

BL 馬達左折 Motor Left Side



CAD圖面可至www.toyorobot.com下載

Please download the CAD file from TOYO's website : www.toyorobot.com

單位 Unit : mm

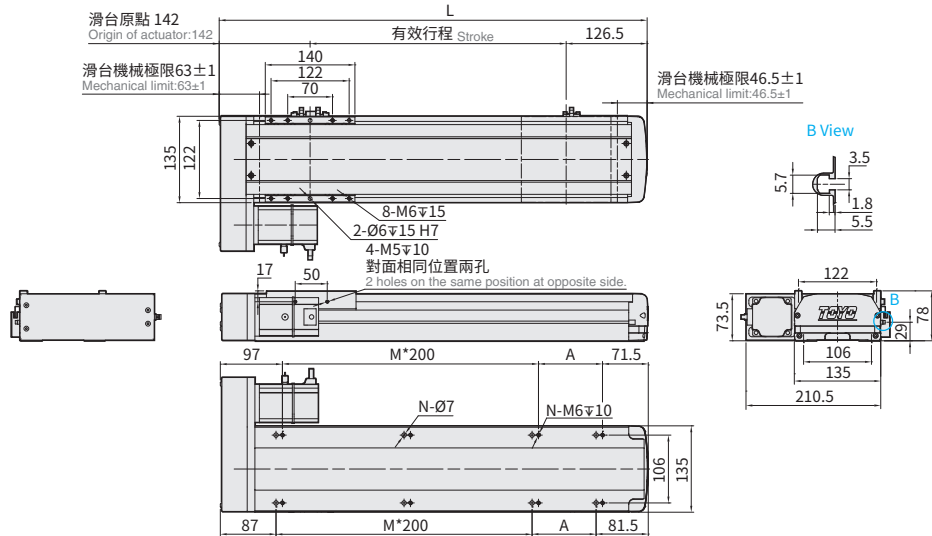

有效行程 Stroke	50	100	150	200	250	300	350	400	450	500	550	600	650	700	750	800	850	900	950	1000	1050
極限行程 Limit Stroke (±1)	69	119	169	219	269	319	369	419	469	519	569	619	669	719	769	819	869	919	969	1019	1069
L	318.5	368.5	418.5	468.5	518.5	568.5	618.5	668.5	718.5	768.5	818.5	868.5	918.5	968.5	1018.5	1068.5	1118.5	1168.5	1218.5	1268.5	1318.5
A	150	200	50	100	150	200	50	100	150	200	50	100	150	200	50	100	150	200	50	100	150
M	0	0	1	1	1	1	2	2	2	2	3	3	3	3	4	4	4	4	5	5	5
N	4	4	6	6	6	6	8	8	8	8	10	10	10	10	12	12	12	12	14	14	14
KG	9.4	9.94	10.48	11.02	11.56	12.1	12.64	13.18	13.72	14.26	14.8	15.34	15.88	16.42	16.96	17.5	18.04	18.58	19.12	19.66	20.2
線速度 Linear Speed mm/s	導程 Lead 5	300										275	250	225	200	175	150	125	100		
	導程 Lead 10	600										550	500	450	400	350	300	250	200		
	導程 Lead 20	1200										1100	1000	900	800	700	600	500	400		
	導程 Lead 32	1920										1760	1600	1440	1280	1120	960	800	640		

BR 馬達右折 Motor Right Side



CAD圖面可至www.toyorobot.com下載

Please download the CAD file from TOYO's website : www.toyorobot.com

單位 Unit : mm

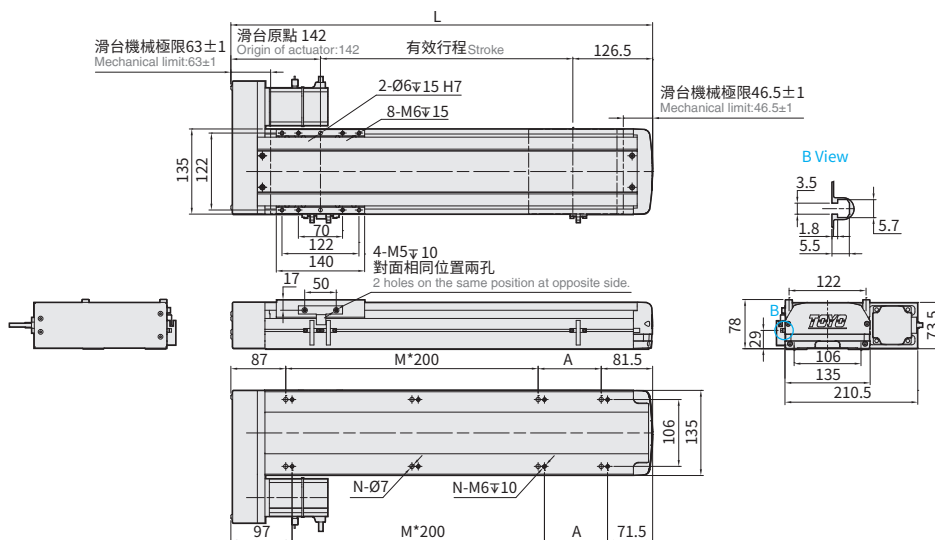

有效行程 Stroke	50	100	150	200	250	300	350	400	450	500	550	600	650	700	750	800	850	900	950	1000	1050
極限行程 Limit Stroke (±1)	69	119	169	219	269	319	369	419	469	519	569	619	669	719	769	819	869	919	969	1019	1069
L	318.5	368.5	418.5	468.5	518.5	568.5	618.5	668.5	718.5	768.5	818.5	868.5	918.5	968.5	1018.5	1068.5	1118.5	1168.5	1218.5	1268.5	1318.5
A	150	200	50	100	150	200	50	100	150	200	50	100	150	200	50	100	150	200	50	100	150
M	0	0	1	1	1	1	2	2	2	2	3	3	3	3	4	4	4	4	5	5	5
N	4	4	6	6	6	6	8	8	8	8	10	10	10	10	12	12	12	12	14	14	14
KG	9.4	9.94	10.48	11.02	11.56	12.1	12.64	13.18	13.72	14.26	14.8	15.34	15.88	16.42	16.96	17.5	18.04	18.58	19.12	19.66	20.2
線速度 Linear Speed mm/s	導程 Lead 5	300										275	250	225	200	175	150	125	100		
	導程 Lead 10	600										550	500	450	400	350	300	250	200		
	導程 Lead 20	1200										1100	1000	900	800	700	600	500	400		
	導程 Lead 32	1920										1760	1600	1440	1280	1120	960	800	640		

ETH Series

ETH13

ETH14

ETH17

ETH22

ETH17M

ETH22M

ETH14 單軸 /1-axis

BM 馬達下折 Motor Bottom Side



CAD圖面可至 www.toyorobot.com 下載
Please download the CAD file from TOYO's website : www.toyorobot.com

單位 Unit : mm

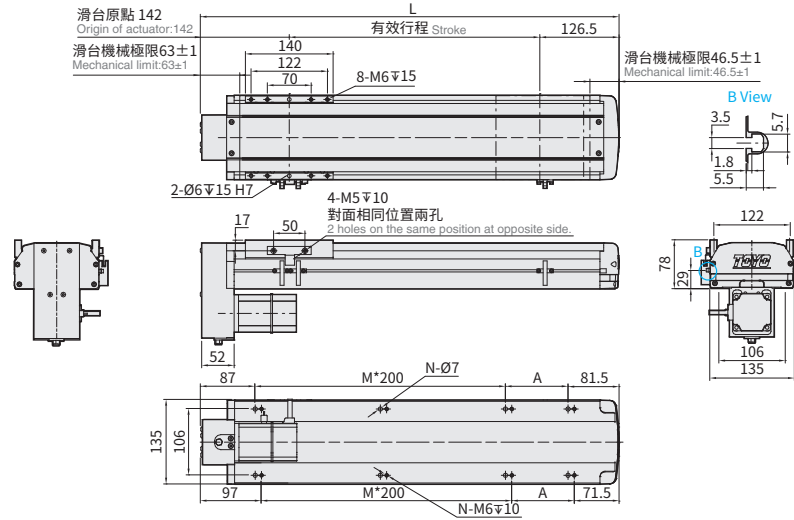

有效行程 Stroke	50	100	150	200	250	300	350	400	450	500	550	600	650	700	750	800	850	900	950	1000	1050		
極限行程 Limit Stroke (±1)	69	119	169	219	269	319	369	419	469	519	569	619	669	719	769	819	869	919	969	1019	1069		
L	318.5	368.5	418.5	468.5	518.5	568.5	618.5	668.5	718.5	768.5	818.5	868.5	918.5	968.5	1018.5	1068.5	1118.5	1168.5	1218.5	1268.5	1318.5		
A	150	200	50	100	150	200	50	100	150	200	50	100	150	200	50	100	150	200	50	100	150		
M	0	0	1	1	1	1	2	2	2	2	3	3	3	3	4	4	4	4	5	5	5		
N	4	4	6	6	6	6	8	8	8	8	10	10	10	10	12	12	12	12	14	14	14		
KG	9.4	9.94	10.48	11.02	11.56	12.1	12.64	13.18	13.72	14.26	14.8	15.34	15.88	16.42	16.96	17.5	18.04	18.58	19.12	19.66	20.2		
線速度 Linear Speed mm/s	導程 Lead 5												275	250	225	200	175	150	125	100			
	導程 Lead 10												550	500	450	400	350	300	250	200			
	導程 Lead 20												1100	1000	900	800	700	600	500	400			
	導程 Lead 32												1760	1600	1440	1280	1120	960	800	640			

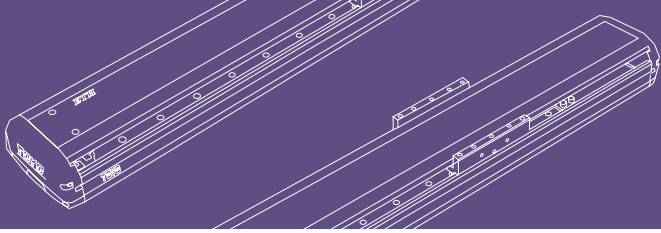

免費服務專線：大陸 400-875-0009 台灣 0800-800-893
Toll-Free Number China Taiwan

應用例
Application

一般 / 螺桿仕様
ETH

一般 / 皮帶仕様
ETB / M

無塵 / 螺桿仕様
GCH / ECH

無塵 / 皮帶仕様
ECB

直交連結
XYGT / XTH / XYTB

參考資料
Reference

Memo

ETH Series

ETH13

ETH14

ETH17

ETH22

ETH17M

ETH22M



精度
±0.005 mm

- 最大行程 1250mm (Maximum Stroke)
- 最高速度 2400mm/s (Maximum Speed)
- 馬達容量 400W (Motor Output)
- 滾珠螺桿 ø20mm (Ball Screw)
- 直線滑軌 20X15-2 支 (Linear Guide)

型號表示方式 Ordering Method

ETH17 - L5 - 100 - M - M40B - C4N5 - 參照右頁 - 0001

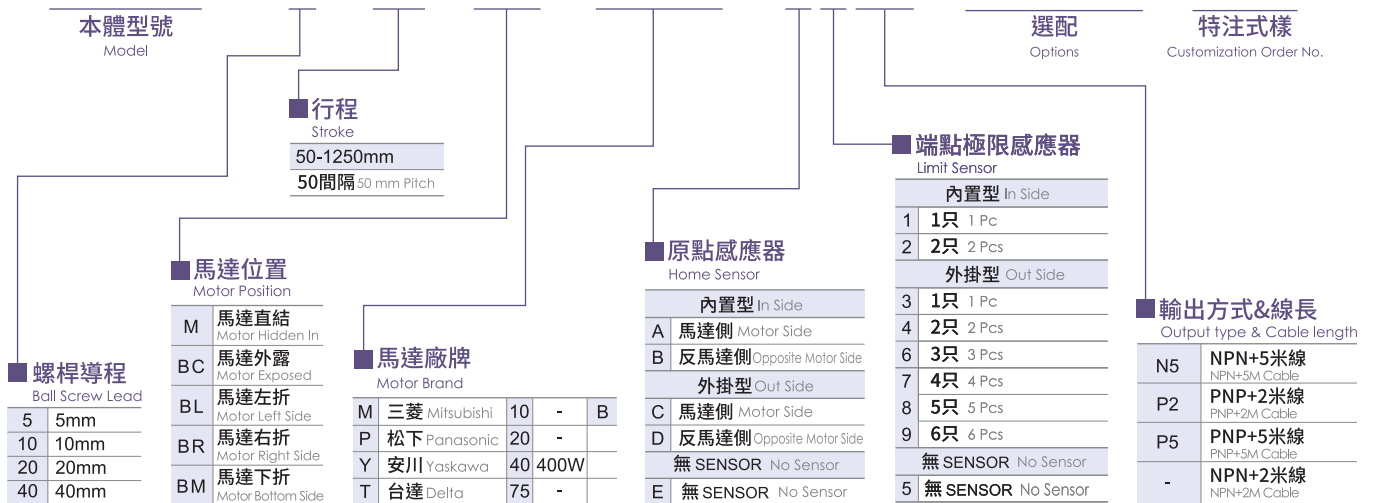

*若無煞車則不表示。*If No Brake, No Description.

*感應器由客戶自行安裝,圖面最多示意為3只
*The sensors are installed by customers themselves, and the diagram shows a maximum of 3 sensors.

基本仕様 Specification

性能	位置重複精度 Repeatability	mm	±0.005				
	螺桿導程 Lead	mm	5	10	20	40	
	最高轉速 Maximum Rotating speed	rpm	3600	3600	3600	3600	
	最高速度 Maximum linear speed ※1	mm/s	300	600	1200	2400	
	最大可搬重量 Maximum Payload	水平使用 Horizontal	kg	120	110	75	22
		垂直使用 Vertical	kg	40	30	14	7
	定格推力 Rated Thrust	N	1388	694	347	147	
部品	標準行程 Stroke (increments)	mm	50-1250mm/50 間隔 (50 increments)				
	AC 伺服馬達容量 AC Servo Motor Output	W	400				
	滾珠螺桿外徑 Ball Screw Ø	mm	C7Ø20				
	高剛性直線滑軌 High Rigidity Linear Guide	mm	W20XH15				
	連軸器 Coupling	mm	12X14				
	原點感應器 Home Sensor	外掛 Outside		T62N2 (NPN+2 米線) (NPN+2M Cable)			
		內置 Built-In		T64N2 (NPN+2 米線) (NPN+2M Cable)			

※1 長行程時，會產生螺桿偏擺，需將速度調降（線速度請參閱尺寸圖下方表格）
During in a long stroke, it causes ballscrew deflection, the speed must reduce. (Please refer to the linear velocity from the data sheet below the dimension graph.)

容許負載力距表 Allowable Overhang

(單位 Unit : mm)				(單位 Unit : mm)				(單位 Unit : mm)		
水平安裝 Horizontal Installation				壁掛安裝 Wall Installation				垂直安裝 Vertical Installation		
	A	B	C	A	B	C	A	C		
導程 5 Lead	70kg	3235	342	395	342	3235	20kg	1335	1335	
	90kg	2482	256	297	256	2482	30kg	890	890	
	120kg	1850	182	210	182	1850	40kg	667	667	
導程 10 Lead	65kg	1677	323	351	323	1677	15kg	1545	1545	
	85kg	1249	237	258	237	1249	25kg	927	927	
	110kg	933	174	189	174	933	30kg	772	772	
導程 20 Lead	35kg	1201	470	442	470	1201	8kg	2042	2042	
	55kg	739	283	268	283	739	10kg	1633	1633	
	75kg	523	197	186	197	523	14kg	1167	1167	
導程 40 Lead	10kg	1426	1136	809	1136	1426	3kg	2980	2980	
	15kg	939	743	531	743	939	5kg	1788	1788	
	22kg	629	493	354	493	629	7kg	1277	1277	

靜額定扭矩 Static Loading Moment

		(單位 Unit : N.m)
MY		1032
MP		1034
MR		908

* 力矩表所表示的數據，代表荷重的重心位置於單一方向容許懸出的長度。
The data represented by the moment table is the center of gravity of the load. The length of the overhang is allowed in a single direction.
* 符合型錄規範的正常使用下，保證壽命為 10000 公里。
Operation life is 10,000km when the product is using under the specified conditions.
* 倒吊使用無法套用標準規範，如有需求請洽詢我司業務。
Data information is not for ceiling-mount inverse use. Contact us for the details if you want to apply ceiling-mount inverse usage.
* 壽命及力矩是以馬達加速設定 0.2 秒計算。
The life and torque are calculated by setting the motor acceleration and deceleration for 0.2 seconds.

選配 Options

NL			P			EB			MM			CMK				
外拉式注油嘴位置 External oil injection nozzle position			標準 PIN 孔 Standard PIN hole			外觀黑色處理 Outer layer is treated with black oxide			指定馬達出線方向 Selectable Cable Leading Direction			馬達傳動配件追加鍵槽 Additional keyway for motor drive parts				
代號 Code	說明 Instructions	需參照 Refer to	代號 Code	說明 Instructions	需參照 Refer to	代號 Code	說明 Instructions	需參照 Refer to	代號 Code	說明 Instructions	需參照 Refer to	代號 Code	說明 Instructions	出貨型式 Shipment type	需參照 Refer to	
NL	滑座右側 On The Right of The Slider	P.675 ~ P.676	P	標準 PIN 孔 Standard PIN hole	P.677	EB	黑色 Black	本體 Main Body	P.678	MW	朝上 Upper side	P.679 ~ P.680	CMK	單邊 (限定馬達側) Single (Limited to the motor side)	BC/M	鍵槽式聯軸器 Keyway Coupling
NR	滑座右側 On The Right of The Slider		EB	原色 Original color			不銹鋼 板材 Stainless steel plate			MM	朝下 Bottom side			BL/BR/BM	鍵槽式皮帶輪 Keyway Belt Pulley	
NRL	滑座雙邊注油 Slide both sides for oil injection		SKY	雙邊 Double		不適用 Not Applicable	ML	朝左 Left side		SKN	雙邊 Double		BC/M	無聯軸器 (請自行購買安裝) Without Coupling (Please purchase and install by yourself)	P.681 ~ P.682	BL/BR/BM
					MR	朝右 Right side										

ETH17 單軸 /1-axis



M 馬達直結 Motor Hidden In



CAD圖面可至 www.toyorobot.com 下載
Please download the CAD file from TOYO's website : www.toyorobot.com

單位 Unit : mm

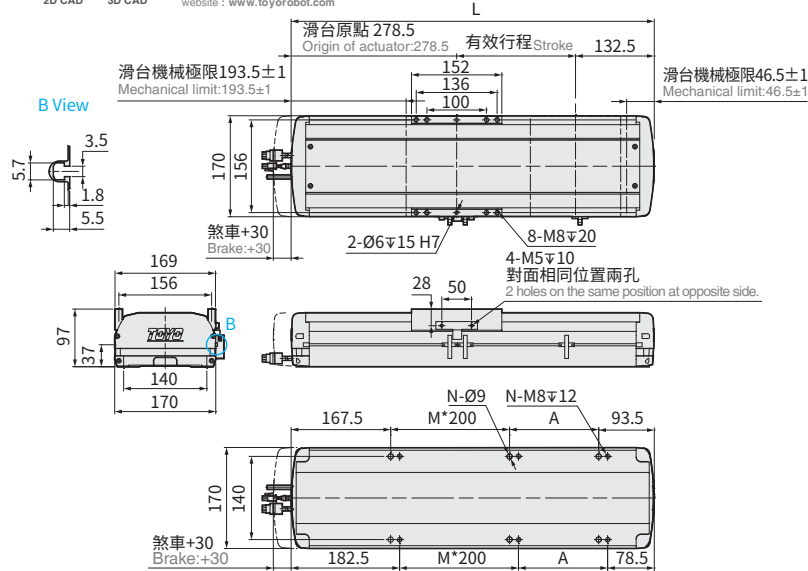

有效行程 Stroke	50	100	150	200	250	300	350	400	450	500	550	600	650	700	750	800	850	900	950	1000	1050	1100	1150	1200	1250																
極限行程 Limit Stroke (±1)	69	119	169	219	269	319	369	419	469	519	569	619	669	719	769	819	869	919	969	1019	1069	1119	1169	1219	1269																
L	461	511	561	611	661	711	761	811	861	911	961	1011	1061	1111	1161	1211	1261	1311	1361	1411	1461	1511	1561	1611	1661																
A	200	50	100	150	200	50	100	150	200	50	100	150	200	50	100	150	200	50	100	150	200	50	100	150	200																
M	0	1	1	1	1	2	2	2	2	3	3	3	3	4	4	4	4	5	5	5	5	6	6	6	6																
N	4	6	6	6	6	8	8	8	8	10	10	10	10	12	12	12	12	14	14	14	14	16	16	16	16																
KG	10.11	10.89	11.67	12.45	13.22	14	14.78	15.55	16.33	17.11	17.88	18.66	19.44	20.22	20.99	21.77	22.55	23.33	24.1	24.88	25.66	26.44	27.21	27.99	28.77																
線速度 Linear Speed mm/s	導程 Lead 5	300																																							
	導程 Lead 10	600																																							
	導程 Lead 20	1200																																							
	導程 Lead 40	2400																																							
		267	250	225	225	200	200	175	175	150	150	533	500	450	450	400	400	350	350	300	300	1067	1000	900	900	800	800	700	700	600	600	2133	2000	1800	1800	1600	1600	1400	1400	1200	1200

BC 馬達外露 Motor Exposed



CAD圖面可至 www.toyorobot.com 下載
Please download the CAD file from TOYO's website : www.toyorobot.com

單位 Unit : mm

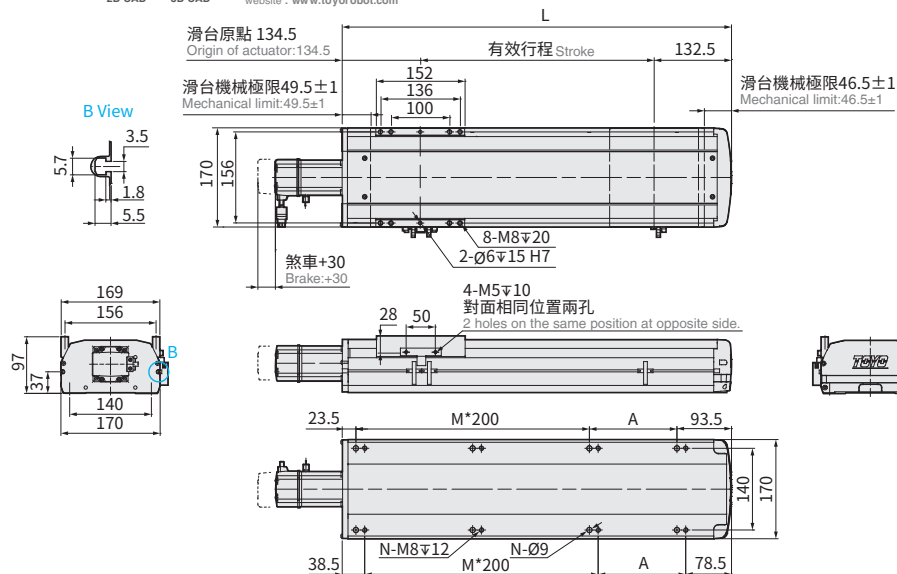

有效行程 Stroke	50	100	150	200	250	300	350	400	450	500	550	600	650	700	750	800	850	900	950	1000	1050	1100	1150	1200	1250																
極限行程 Limit Stroke (±1)	69	119	169	219	269	319	369	419	469	519	569	619	669	719	769	819	869	919	969	1019	1069	1119	1169	1219	1269																
L	317	367	417	467	517	567	617	667	717	767	817	867	917	967	1017	1067	1117	1167	1217	1267	1317	1367	1417	1467	1517																
A	200	50	100	150	200	50	100	150	200	50	100	150	200	50	100	150	200	50	100	150	200	50	100	150	200																
M	0	1	1	1	1	2	2	2	2	3	3	3	3	4	4	4	4	5	5	5	5	6	6	6	6																
N	4	6	6	6	6	8	8	8	8	10	10	10	10	12	12	12	12	14	14	14	14	16	16	16	16																
KG	9.61	10.2	10.79	11.57	12.34	13.11	13.88	14.65	15.42	16.19	16.96	17.73	18.5	19.28	20.05	20.82	21.59	22.36	23.13	23.9	24.67	25.44	26.21	26.98	27.75																
線速度 Linear Speed mm/s	導程 Lead 5	300																																							
	導程 Lead 10	600																																							
	導程 Lead 20	1200																																							
	導程 Lead 40	2400																																							
		267	250	225	225	200	200	175	175	150	150	533	500	450	450	400	400	350	350	300	300	1067	1000	900	900	800	800	700	700	600	600	2133	2000	1800	1800	1600	1600	1400	1400	1200	1200

BL 馬達左折 Motor Left Side



CAD圖面可至www.toyorobot.com下載

Please download the CAD file from TOYO's website : www.toyorobot.com

單位 Unit : mm

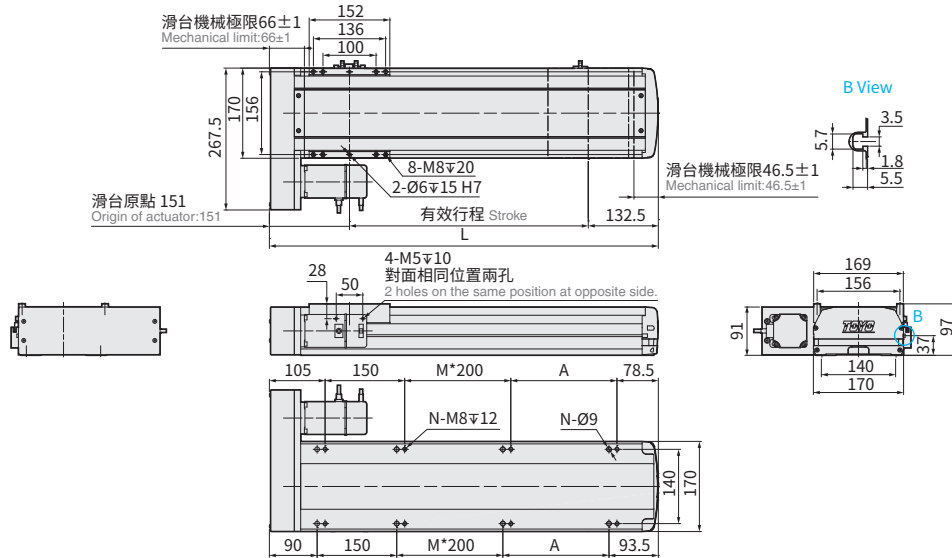

有效行程 Stroke	50	100	150	200	250	300	350	400	450	500	550	600	650	700	750	800	850	900	950	1000	1050	1100	1150	1200	1250
極限行程 Limit Stroke (±1)	69	119	169	219	269	319	369	419	469	519	569	619	669	719	769	819	869	919	969	1019	1069	1119	1169	1219	1269
L	333.5	383.5	433.5	483.5	533.5	583.5	633.5	683.5	733.5	783.5	833.5	883.5	933.5	983.5	1033.5	1083.5	1133.5	1183.5	1233.5	1283.5	1333.5	1383.5	1433.5	1483.5	1533.5
A	0	50	100	150	200	50	100	150	200	50	100	150	200	50	100	150	200	50	100	150	200	50	100	150	200
M	0	0	0	0	0	1	1	1	1	2	2	2	2	3	3	3	3	4	4	4	4	5	5	5	5
N	4	6	6	6	6	8	8	8	8	10	10	10	10	12	12	12	12	14	14	14	14	16	16	16	16
KG	9.53	10.3	11.07	11.84	12.61	13.38	14.15	14.92	15.69	16.47	17.24	18.01	18.78	19.55	20.32	21.09	21.86	22.63	23.4	24.18	24.95	25.72	26.49	27.26	28.03
線速度 Linear Speed mm/s	導程 Lead 5	300																							
	導程 Lead 10	600																							
	導程 Lead 20	1200																							
	導程 Lead 40	2400																							

BR 馬達右折 Motor Right Side



CAD圖面可至www.toyorobot.com下載

Please download the CAD file from TOYO's website : www.toyorobot.com

單位 Unit : mm

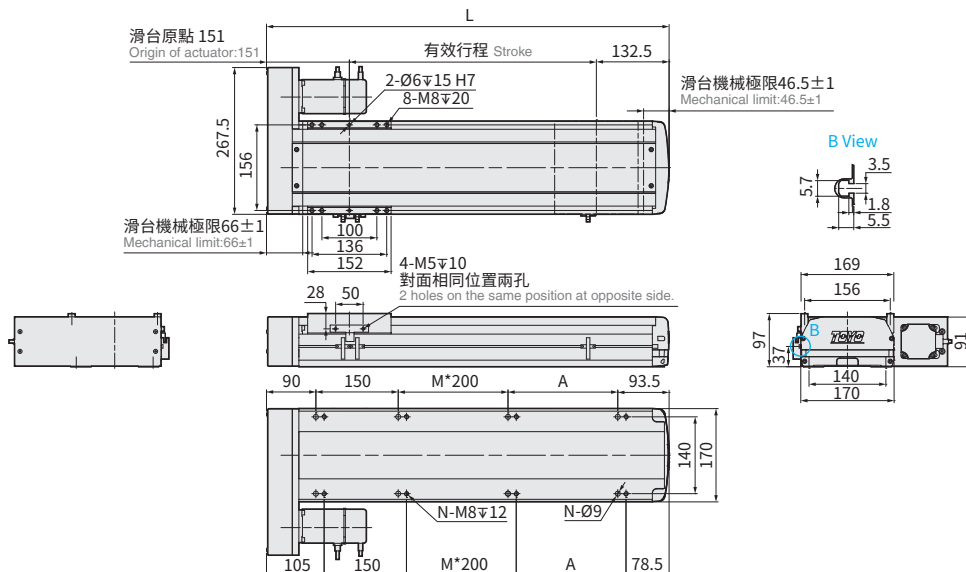

有效行程 Stroke	50	100	150	200	250	300	350	400	450	500	550	600	650	700	750	800	850	900	950	1000	1050	1100	1150	1200	1250
極限行程 Limit Stroke (±1)	69	119	169	219	269	319	369	419	469	519	569	619	669	719	769	819	869	919	969	1019	1069	1119	1169	1219	1269
L	333.5	383.5	433.5	483.5	533.5	583.5	633.5	683.5	733.5	783.5	833.5	883.5	933.5	983.5	1033.5	1083.5	1133.5	1183.5	1233.5	1283.5	1333.5	1383.5	1433.5	1483.5	1533.5
A	0	50	100	150	200	50	100	150	200	50	100	150	200	50	100	150	200	50	100	150	200	50	100	150	200
M	0	0	0	0	0	1	1	1	1	2	2	2	2	3	3	3	3	4	4	4	4	5	5	5	5
N	4	6	6	6	6	8	8	8	8	10	10	10	10	12	12	12	12	14	14	14	14	16	16	16	16
KG	9.53	10.3	11.07	11.84	12.61	13.38	14.15	14.92	15.69	16.47	17.24	18.01	18.78	19.55	20.32	21.09	21.86	22.63	23.4	24.18	24.95	25.72	26.49	27.26	28.03
線速度 Linear Speed mm/s	導程 Lead 5	300																							
	導程 Lead 10	600																							
	導程 Lead 20	1200																							
	導程 Lead 40	2400																							

ETH17 單軸 /1-axis



BM 馬達下折 Motor Bottom Side



CAD圖面可至www.toyorobot.com下載
Please download the CAD file from TOYO's website : www.toyorobot.com

單位 Unit : mm

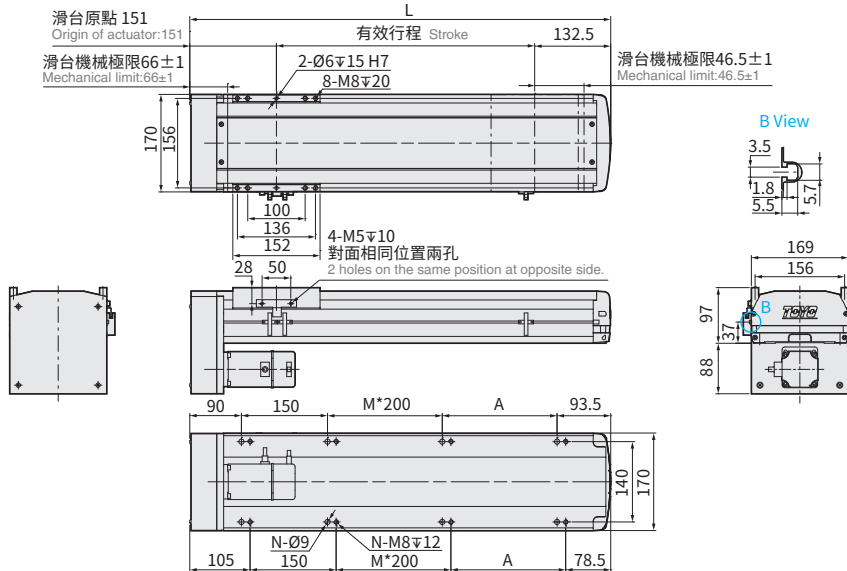

有效行程 Stroke	50	100	150	200	250	300	350	400	450	500	550	600	650	700	750	800	850	900	950	1000	1050	1100	1150	1200	1250	
極限行程 Limit Stroke (± 1)	69	119	169	219	269	319	369	419	469	519	569	619	669	719	769	819	869	919	969	1019	1069	1119	1169	1219	1269	
L	333.5	383.5	433.5	483.5	533.5	583.5	633.5	683.5	733.5	783.5	833.5	883.5	933.5	983.5	1033.5	1083.5	1133.5	1183.5	1233.5	1283.5	1333.5	1383.5	1433.5	1483.5	1533.5	
A	0	50	100	150	200	50	100	150	200	50	100	150	200	50	100	150	200	50	100	150	200	50	100	150	200	
M	0	0	0	0	0	1	1	1	1	2	2	2	2	3	3	3	3	4	4	4	4	5	5	5	5	
N	4	6	6	6	6	8	8	8	8	10	10	10	10	12	12	12	12	14	14	14	14	16	16	16	16	
KG	9.53	10.3	11.07	11.84	12.61	13.38	14.15	14.92	15.69	16.47	17.24	18.01	18.78	19.55	20.32	21.09	21.86	22.63	23.4	24.18	24.95	25.72	26.49	27.26	28.03	
線速度 Linear Speed mm/s	導程 Lead 5	300																								
	導程 Lead 10	600																								
	導程 Lead 20	1200																								
	導程 Lead 40	2400																								
																	267	250	225	225	200	200	175	175	150	150
																	533	500	450	450	400	400	350	350	300	300
																	1067	1000	900	900	800	800	700	700	600	600
																	2133	2000	1800	1800	1600	1600	1400	1400	1200	1200

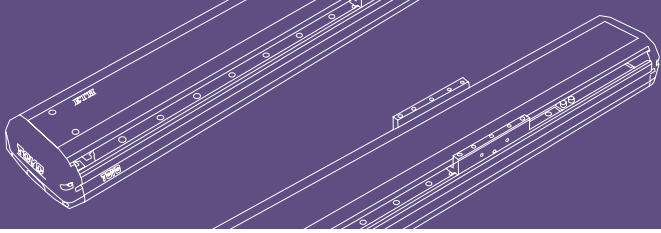

免費服務專線：大陸 400-875-0009 台灣 0800-800-893
Toll-Free Number China Taiwan

應用例
Application

一般 / 螺桿仕様
ETH

一般 / 皮帶仕様
ETB / M

無塵 / 螺桿仕様
GCH / ECH

無塵 / 皮帶仕様
ECB

直交連結
XYGT / XTH / XYTB

參考資料
Reference

Memo

ETH Series

ETH13

ETH14

ETH17

ETH22

ETH17M

ETH22M

精度
±0.005 mm



最大行程 1250mm
Maximum Stroke
最高速度 2400mm/s
Maximum Speed
馬達容量 750W
Motor Output
滾珠螺桿 ø20mm
Ball Screw
直線滑軌 20X15-2 支
Linear Guide

型號表示方式 Ordering Method

ETH17 - L5 - 50 - BC - M75B - C4N5 - 參照右頁 - 0001

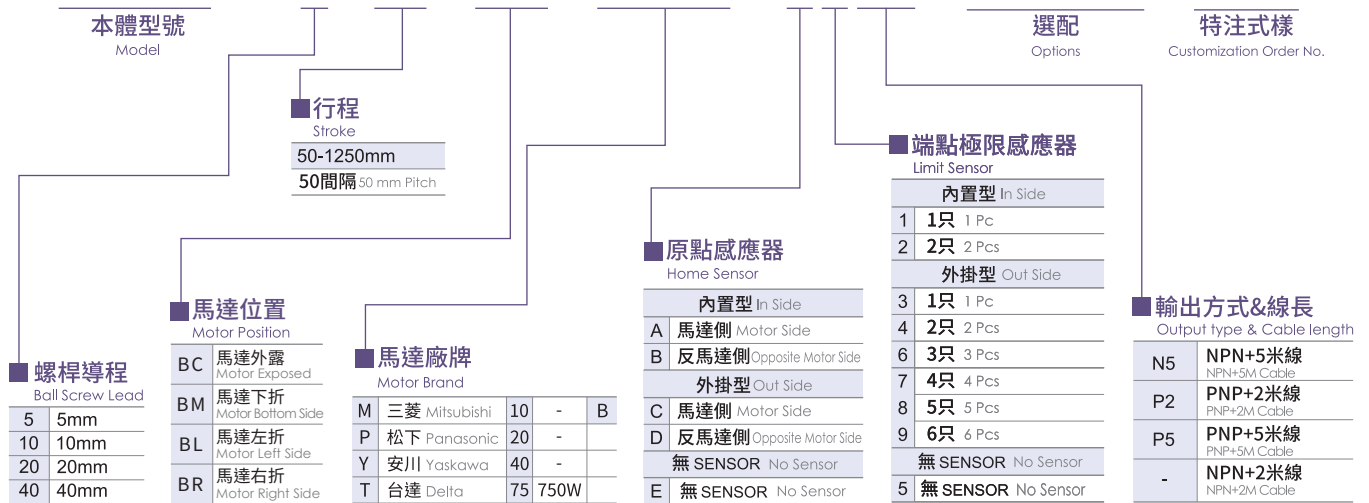

若無煞車則不表示。 If No Brake, No Description.

*感應器由客戶自行安裝,圖面最多示意為3只
*The sensors are installed by customers themselves, and the diagram shows a maximum of 3 sensors.

基本仕様 Specification

性能	位置重複精度 Repeatability	mm	±0.005				
	螺桿導程 Lead	mm	5	10	20	40	
	最高轉速 Maximum Rotating speed	rpm	3600	3600	3600	3600	
	最高速度 Maximum linear speed ※1	mm/s	300	600	1200	2400	
	最大可搬重量 Maximum Payload	水平使用 Horizontal	kg	120	120	83	43
		垂直使用 Vertical	kg	50	40	25	12
	定格推力 Rated Thrust	N	2563	1281	640	320	
	標準行程 Stroke (increments)	mm	50-1250mm/50 間隔 (50 increments)				
部品	AC 伺服馬達容量 AC Servo Motor Output	W	750				
	滾珠螺桿外徑 Ball Screw Ø	mm	C7Ø20				
	高剛性直線滑軌 High Rigidity Linear Guide	mm	W20XH15				
	連軸器 Coupling	mm	12X19				
	原點感應器 Home Sensor	外掛 Outside		T62N2 (NPN+2 米線) (NPN+2M Cable)			
		內置 Built-In		T64N2 (NPN+2 米線) (NPN+2M Cable)			

※1 長行程時，會產生螺桿偏擺，需將速度調降 (線速度請參閱尺寸圖下方表格)

During in a long stroke, it causes ballscrew deflection, the speed must reduce. (Please refer to the linear velocity from the data sheet below the dimension graph.)

容許負載力距表 Allowable Overhang

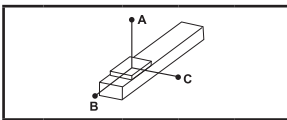

(單位 Unit : mm)

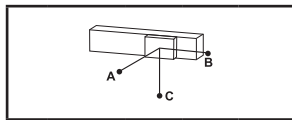

(單位 Unit : mm)

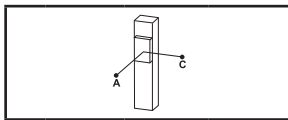

(單位 Unit : mm)

水平安裝 Horizontal Installation		A	B	C
導程 5 Lead	70kg	3235	342	395
	95kg	2337	241	279
	120kg	1850	182	210
導程 10 Lead	65kg	1677	323	351
	93kg	1130	213	232
導程 20 Lead	35kg	1201	470	442
	60kg	671	256	242
導程 40 Lead	83kg	466	174	165
	15kg	939	743	531
	29kg	469	364	262
	43kg	305	231	168

壁掛安裝 Wall Installation		A	B	C
導程 5 Lead	70kg	395	342	3235
	95kg	279	241	2337
	120kg	210	182	1850
導程 10 Lead	65kg	351	323	1677
	93kg	232	213	1130
導程 20 Lead	35kg	442	470	1201
	60kg	242	256	671
導程 40 Lead	83kg	165	174	466
	15kg	531	743	939
	29kg	262	364	469
	43kg	168	231	305

垂直安裝 Vertical Installation		A	C
導程 5 Lead	20kg	1335	1335
	35kg	763	763
	50kg	534	534
導程 10 Lead	15kg	1545	1545
	25kg	927	927
導程 20 Lead	10kg	1633	1633
	18kg	907	907
導程 40 Lead	25kg	653	653
	7kg	1277	1277
	9kg	993	993
	12kg	745	745

靜額定扭矩 Static Loading Moment

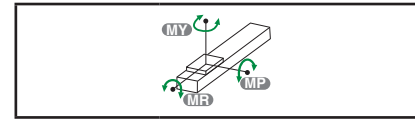

(單位 Unit : N.m)

MY	1032
MP	1034
MR	908

* 力矩表所表示的數據，代表荷重的重心位置於單一方向容許懸出的長度。
 The data represented by the moment table is the center of gravity of the load. The length of the overhang is allowed in a single direction.
 * 符合型錄規範的正常使用下，保證壽命為 10000 公里。
 Operation life is 10,000km when the product is using under the specified conditions.
 * 倒吊使用無法套用標準規範，如有需求請洽詢我司業務。
 Data information is not for ceiling-mount inverse use. Contact us for the details if you want to apply ceiling-mount inverse usage.
 * 壽命及力矩是以馬達加減速設定 0.2 秒計算。
 The life and torque are calculated by setting the motor acceleration and deceleration for 0.2 seconds.

選配 Options

NL		P		EB		MM		CMK	
外拉式注油嘴位置 External oil injection nozzle position		標準 PIN 孔 Standard PIN hole		外觀黑色處理 Outer layer is treated with black oxide		指定馬達出線方向 Selectable Cable Leading Direction		馬達傳動配件追加鍵槽 Additional keyway for motor drive parts	
代號 Code	說明 Instructions	代號 Code	說明 Instructions	代號 Code	說明 Instructions	代號 Code	說明 Instructions	代號 Code	說明 Instructions
	需參照 Refer to		需參照 Refer to		需參照 Refer to		需參照 Refer to		需參照 Refer to
NL	滑座右側 On The Right of The Slider	P	標準 PIN 孔 Standard PIN hole	EB	黑色 Black	MW	朝上 Upper side	CMK	單邊 (限定馬達側) Single (Limited to the motor side)
NR	滑座右側 On The Right of The Slider	P.675 ~ P.676			本體 Main Body	MM	朝下 Bottom side		BC
NRL	滑座雙邊注油 Slide both sides for oil injection		P.677		不銹鋼 Stainless steel plate	ML	朝左 Left side		BL/BR/BM
					螺絲 Screw	MR	朝右 Right side		不適用 Not Applicable
								SKY	雙邊 Double
									BC
									BL/BR/BM
								SKN	雙邊 Double
									BC
									BL/BR/BM

ETH17 單軸 /1-axis



BC 馬達外露 Motor Exposed



• CAD圖面可至www.toyorobot.com下載 •
Please download the CAD file from TOYO's website : www.toyorobot.com

單位 Unit : mm

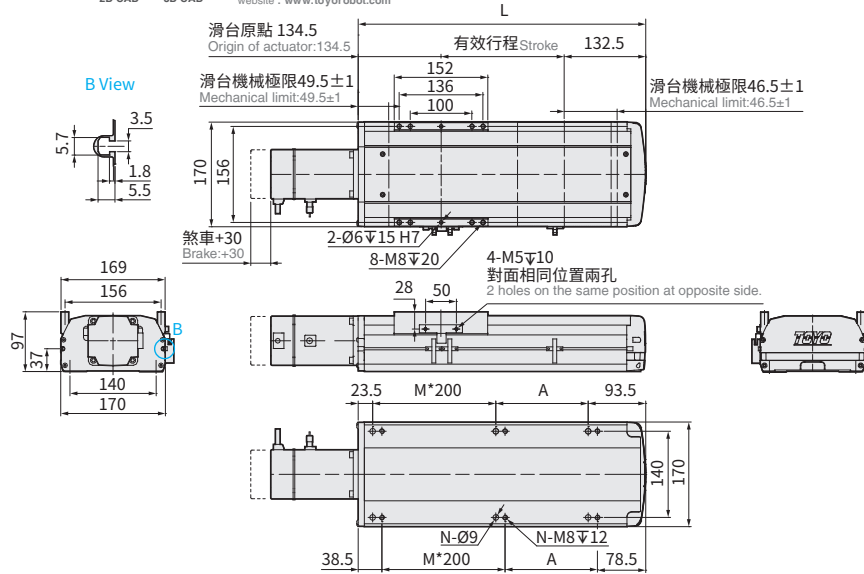

有效行程 Stroke	50	100	150	200	250	300	350	400	450	500	550	600	650	700	750	800	850	900	950	1000	1050	1100	1150	1200	1250
極限行程 Limit Stroke (±1)	69	119	169	219	269	319	369	419	469	519	569	619	669	719	769	819	869	919	969	1019	1069	1119	1169	1219	1269
L	317	367	417	467	517	567	617	667	717	767	817	867	917	967	1017	1067	1117	1167	1217	1267	1317	1367	1417	1467	1517
A	200	50	100	150	200	50	100	150	200	50	100	150	200	50	100	150	200	50	100	150	200	50	100	150	200
M	0	1	1	1	1	2	2	2	2	3	3	3	3	4	4	4	4	5	5	5	5	6	6	6	6
N	4	6	6	6	6	8	8	8	8	10	10	10	10	12	12	12	12	14	14	14	14	16	16	16	16
KG	9.61	10.02	10.79	11.57	12.34	13.11	13.88	14.65	15.42	16.19	16.96	17.73	18.5	19.28	20.05	20.82	21.59	22.36	23.13	23.9	24.67	25.44	26.21	26.98	27.75
線速度 Linear Speed mm/s	導程 Lead 5	300																							
	導程 Lead 10	600																							
	導程 Lead 20	1200																							
	導程 Lead 40	2400																							

BM 馬達下折 Motor Bottom Side



• CAD圖面可至www.toyorobot.com下載 •
Please download the CAD file from TOYO's website : www.toyorobot.com

單位 Unit : mm

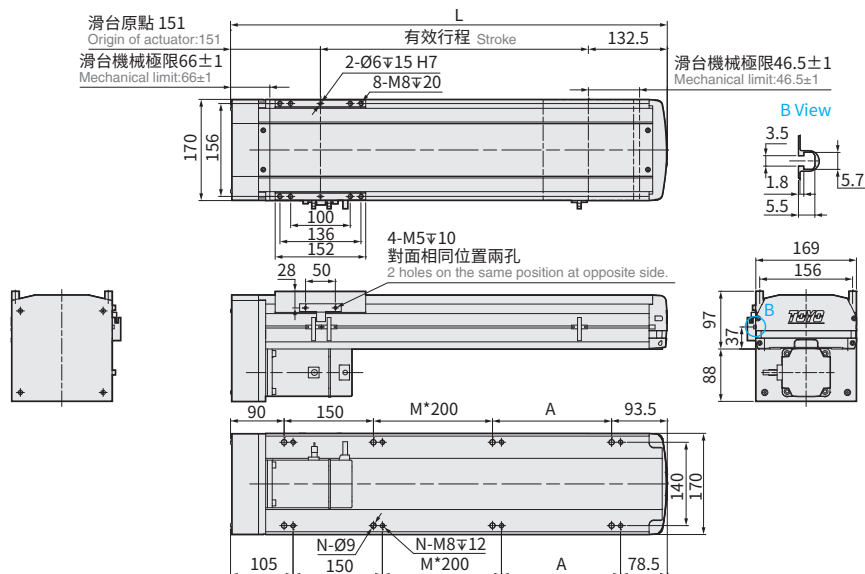

有效行程 Stroke	50	100	150	200	250	300	350	400	450	500	550	600	650	700	750	800	850	900	950	1000	1050	1100	1150	1200	1250
極限行程 Limit Stroke (±1)	69	119	169	219	269	319	369	419	469	519	569	619	669	719	769	819	869	919	969	1019	1069	1119	1169	1219	1269
L	333.5	383.5	433.5	483.5	533.5	583.5	633.5	683.5	733.5	783.5	833.5	883.5	933.5	983.5	1033.5	1083.5	1133.5	1183.5	1233.5	1283.5	1333.5	1383.5	1433.5	1483.5	1533.5
A	0	50	100	150	200	50	100	150	200	50	100	150	200	50	100	150	200	50	100	150	200	50	100	150	200
M	0	0	0	0	0	1	1	1	1	2	2	2	2	3	3	3	3	4	4	4	4	5	5	5	5
N	4	6	6	6	6	8	8	8	8	10	10	10	10	12	12	12	12	14	14	14	14	16	16	16	16
KG	9.53	10.3	11.07	11.84	12.61	13.38	14.15	14.92	15.69	16.47	17.24	18.01	18.78	19.55	20.32	21.09	21.86	22.63	23.4	24.18	24.95	25.72	26.49	27.26	28.03
線速度 Linear Speed mm/s	導程 Lead 5	300																							
	導程 Lead 10	600																							
	導程 Lead 20	1200																							
	導程 Lead 40	2400																							

BL 馬達左折 Motor Left Side



● CAD圖面可至www.toyorobot.com下載 ●

Please download the CAD file from TOYO's website : www.toyorobot.com

單位 Unit : mm

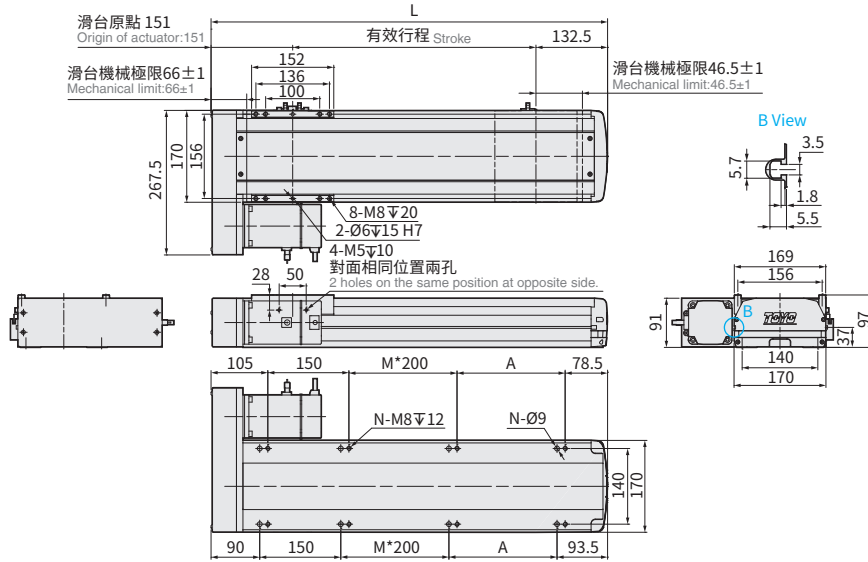

有效行程 Stroke	50	100	150	200	250	300	350	400	450	500	550	600	650	700	750	800	850	900	950	1000	1050	1100	1150	1200	1250
極限行程 Limit Stroke (±1)	69	119	169	219	269	319	369	419	469	519	569	619	669	719	769	819	869	919	969	1019	1069	1119	1169	1219	1269
L	333.5	383.5	433.5	483.5	533.5	583.5	633.5	683.5	733.5	783.5	833.5	883.5	933.5	983.5	1033.5	1083.5	1133.5	1183.5	1233.5	1283.5	1333.5	1383.5	1433.5	1483.5	1533.5
A	0	50	100	150	200	50	100	150	200	50	100	150	200	50	100	150	200	50	100	150	200	50	100	150	200
M	0	0	0	0	0	1	1	1	1	2	2	2	2	3	3	3	3	4	4	4	4	5	5	5	5
N	4	6	6	6	6	8	8	8	8	10	10	10	10	12	12	12	12	14	14	14	14	16	16	16	16
KG	9.53	10.3	11.07	11.84	12.61	13.38	14.15	14.92	15.69	16.47	17.24	18.01	18.78	19.55	20.32	21.09	21.86	22.63	23.4	24.18	24.95	25.72	26.49	27.26	28.03
線速度 Linear Speed mm/s	導程 Lead 5															300									
	導程 Lead 10															600									
	導程 Lead 20															1200									
	導程 Lead 40															2400									

BR 馬達右折 Motor Right Side



● CAD圖面可至www.toyorobot.com下載 ●

Please download the CAD file from TOYO's website : www.toyorobot.com

單位 Unit : mm

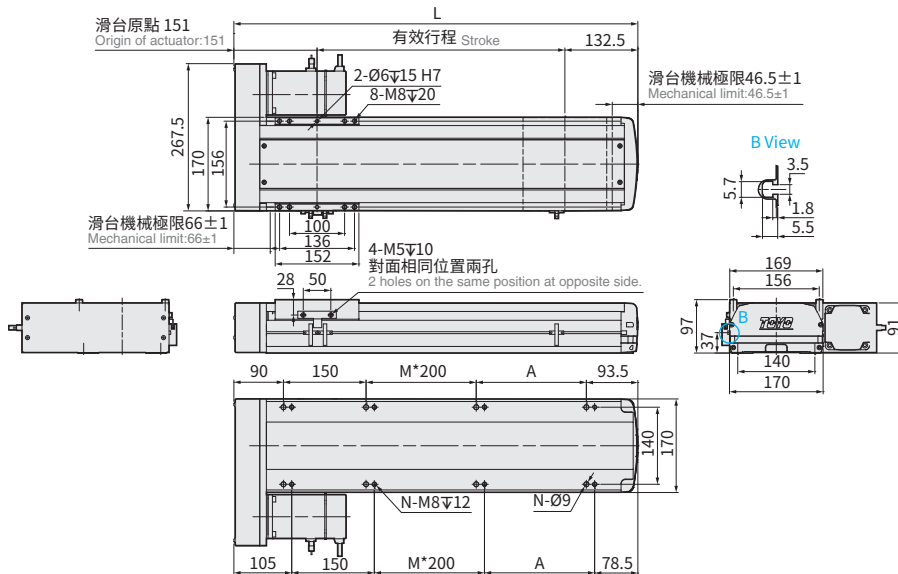

有效行程 Stroke	50	100	150	200	250	300	350	400	450	500	550	600	650	700	750	800	850	900	950	1000	1050	1100	1150	1200	1250
極限行程 Limit Stroke (±1)	69	119	169	219	269	319	369	419	469	519	569	619	669	719	769	819	869	919	969	1019	1069	1119	1169	1219	1269
L	333.5	383.5	433.5	483.5	533.5	583.5	633.5	683.5	733.5	783.5	833.5	883.5	933.5	983.5	1033.5	1083.5	1133.5	1183.5	1233.5	1283.5	1333.5	1383.5	1433.5	1483.5	1533.5
A	0	50	100	150	200	50	100	150	200	50	100	150	200	50	100	150	200	50	100	150	200	50	100	150	200
M	0	0	0	0	0	1	1	1	1	2	2	2	2	3	3	3	3	4	4	4	4	5	5	5	5
N	4	6	6	6	6	8	8	8	8	10	10	10	10	12	12	12	12	14	14	14	14	16	16	16	16
KG	9.53	10.3	11.07	11.84	12.61	13.38	14.15	14.92	15.69	16.47	17.24	18.01	18.78	19.55	20.32	21.09	21.86	22.63	23.4	24.18	24.95	25.72	26.49	27.26	28.03
線速度 Linear Speed mm/s	導程 Lead 5															300									
	導程 Lead 10															600									
	導程 Lead 20															1200									
	導程 Lead 40															2400									

ETH Series

ETH13

ETH14

ETH17

ETH22

ETH17M

ETH22M

精度
±0.005 mm



最大行程 1500mm
Maximum Stroke

最高速度 2400mm/s
Maximum Speed

馬達容量 750W
Motor Output

滾珠螺桿 ø25mm
Ball Screw

直線滑軌 23x18-2支
Linear Guide

型號表示方式 Ordering Method

ETH22 - L10 - 50 - M - M75B - C4N5 - 參照右頁 - 0001

本體型號
Model

行程
Stroke

50-1500mm
50間隔 50 mm Pitch

馬達位置
Motor Position

M	馬達直結 Motor Hidden In
BC	馬達外露 Motor Exposed
BL	馬達左折 Motor Left Side
BR	馬達右折 Motor Right Side
BM	馬達下折 Motor Bottom Side

馬達廠牌
Motor Brand

M	三菱 Mitsubishi	10	-	B
P	松下 Panasonic	20	-	
Y	安川 Yaskawa	40	-	
T	台達 Delta	75	750W	

若無煞車則不表示。 If No Brake, No Description.

螺桿導程
Ball Screw Lead

5	5mm
10	10mm
25	25mm
40	40mm

參照右頁
Refer to the right page.

選配
Options

特注式樣
Customization Order No.

端點極限感應器
Limit Sensor

內置型 In Side

1	1只	1 Pc
2	2只	2 Pcs
外掛型 Out Side		
3	1只	1 Pc
4	2只	2 Pcs
6	3只	3 Pcs
7	4只	4 Pcs
8	5只	5 Pcs
9	6只	6 Pcs
無 SENSOR No Sensor		
5	無 SENSOR	No Sensor

輸出方式&線長
Output type & Cable length

N5	NPN+5米線 NPN+5M Cable
P2	PNP+2米線 PNP+2M Cable
P5	PNP+5米線 PNP+5M Cable
-	NPN+2米線 NPN+2M Cable

*感應器由客戶自行安裝,圖面最多示意為3只

*The sensors are installed by customers themselves, and the diagram shows a maximum of 3 sensors.

基本仕様 Specification

性能	位置重複精度 Repeatability	mm	±0.005				
	螺桿導程 Lead	mm	5	10	25	40	
	最高轉速 Maximum Rotating speed	rpm	3600	3600	3600	3600	
	最高速度 Maximum linear speed ※1	mm/s	300	600	1500	2400	
	最大可搬重量 Maximum Payload	水平使用 Horizontal	kg	150	150	105	43
		垂直使用 Vertical	kg	55	45	20	12
	定格推力 Rated Thrust	N	2563	1281	640	320	
部品	標準行程 Stroke (increments)	mm	50-1500mm/50 間隔 (50 increments)				
	AC 伺服馬達容量 AC Servo Motor Output	W	750				
	滾珠螺桿外徑 Ball Screw Ø	mm	C7Ø25		C7Ø20		
	高剛性直線滑軌 High Rigidity Linear Guide	mm	W23XH18				
	連軸器 Coupling	mm	17X19		12X19		
	原點感應器 Home Sensor	外掛 Outside		T62N2 (NPN+2 米線) (NPN+2M Cable)			
		內置 Built-In		T64N2 (NPN+2 米線) (NPN+2M Cable)			

※1 長行程時，會產生螺桿偏擺，需將速度調降 (線速度請參閱尺寸圖下方表格)

During in a long stroke, it causes ballscrew deflection, the speed must reduce. (Please refer to the linear velocity from the data sheet below the dimension graph.)

容許負載力距表 Allowable Overhang

(單位 Unit : mm)				(單位 Unit : mm)				(單位 Unit : mm)										
水平安裝 Horizontal Installation		A	B	C	壁掛安裝 Wall Installation		A	B	C	垂直安裝 Vertical Installation		A	C					
導程 5 Lead	100kg	5000	618	539	100kg	539	618	5000	30kg	2305	2305	導程 5 Lead	40kg	1729	1729			
	125kg	3880	479	418	125kg	418	479	3880	55kg	1527	1527		導程 10 Lead	25kg	2401	2401		
	150kg	3357	386	337	150kg	337	386	3357	35kg	1715	1715			導程 25 Lead	45kg	1333	1333	
導程 10 Lead	100kg	2800	538	448	100kg	448	538	2800	15kg	2259	2259	導程 40 Lead	18kg		1883	1883		
	125kg	2188	415	345	125kg	345	415	2188	20kg	1694	1694		導程 25 Lead		7kg	3306	3306	
	150kg	1780	333	277	150kg	277	333	1780	9kg	2571	2571			導程 5 Lead	12kg	1928	1928	
導程 25 Lead	65kg	1083	519	371	65kg	371	519	1083	導程 10 Lead	18kg	1883	1883	導程 25 Lead		20kg	1694	1694	
	85kg	803	379	272	85kg	272	379	803		導程 40 Lead	7kg	3306			3306	導程 5 Lead	9kg	2571
	105kg	630	292	210	105kg	210	292	630			導程 25 Lead	18kg		1883	1883		導程 40 Lead	12kg
導程 40 Lead	18kg	2037	1616	982	18kg	982	1616	2037	導程 5 Lead	7kg		3306	3306	導程 25 Lead	20kg	1694		1694
	30kg	1197	938	572	30kg	572	938	1197		導程 10 Lead	9kg	2571	2571		導程 40 Lead	12kg	1928	1928
	43kg	816	630	386	43kg	386	630	816			導程 25 Lead	18kg	1883			1883	導程 5 Lead	20kg

靜額定扭矩 Static Loading Moment

		(單位 Unit : N.m)
MY		2052
MP		2052
MR		1810

* 力矩表所表示的數據，代表荷重的重心位置於單一方向容許懸出的長度。
The data represented by the moment table is the center of gravity of the load. The length of the overhang is allowed in a single direction.
* 符合型錄規範的正常使用下，保證壽命為 10000 公里。
Operation life is 10,000km when the product is using under the specified conditions.
* 倒吊使用無法套用標準規範，如有需求請洽詢我司業務。
Data information is not for ceiling-mount inverse use. Contact us for the details if you want to apply ceiling-mount inverse usage.
* 壽命及力矩是以馬達加減速設定 0.2 秒計算。
The life and torque are calculated by setting the motor acceleration and deceleration for 0.2 seconds.

選配 Options

NL		P		EB		MM		CMK				
外拉式注油嘴位置 External oil injection nozzle position		標準 PIN 孔 Standard PIN hole		外觀黑色處理 Outer layer is treated with black oxide		指定馬達出線方向 Selectable Cable Leading Direction		馬達傳動配件追加鍵槽 Additional keyway for motor drive parts				
代號 Code	說明 Instructions	需參照 Refer to	代號 Code	說明 Instructions	需參照 Refer to	代號 Code	說明 Instructions	代號 Code	說明 Instructions	馬達位置 Motor Position	出貨型式 Shipment type	需參照 Refer to
NL	滑座右側 On The Right of The Slider	P.675 ~ P.676	P	標準 PIN 孔 Standard PIN hole	P.677	EB	黑色 Black	MW	朝上 Upper side	BC/M	鍵槽式聯軸器 Keyway Coupling	P.681 ~ P.682
NR	滑座右側 On The Right of The Slider		EB	原色 Original color		MM	朝下 Bottom side	BL/BR/BM	鍵槽式皮帶輪 Keyway Belt Pulley			
NRL	滑座雙邊注油 Slide both sides for oil injection		EB	不銹鋼 板材 Stainless steel plate 螺絲 Screw		ML	朝左 Left side	不適用 Not Applicable	鍵槽式聯軸器 Keyway Coupling			
						MR	朝右 Right side	SKY	雙邊 Double	BL/BR/BM	不適用 Not Applicable	
								SKN	雙邊 Double	BC/M	無聯軸器 (請自行購買安裝) Without Coupling (Please purchase and install by yourself)	
										BL/BR/BM	不適用 Not Applicable	

M 馬達直結 Motor Hidden In



• CAD圖面可至www.toyorobot.com下載 •
Please download the CAD file from TOYO's website : www.toyorobot.com

單位 Unit : mm

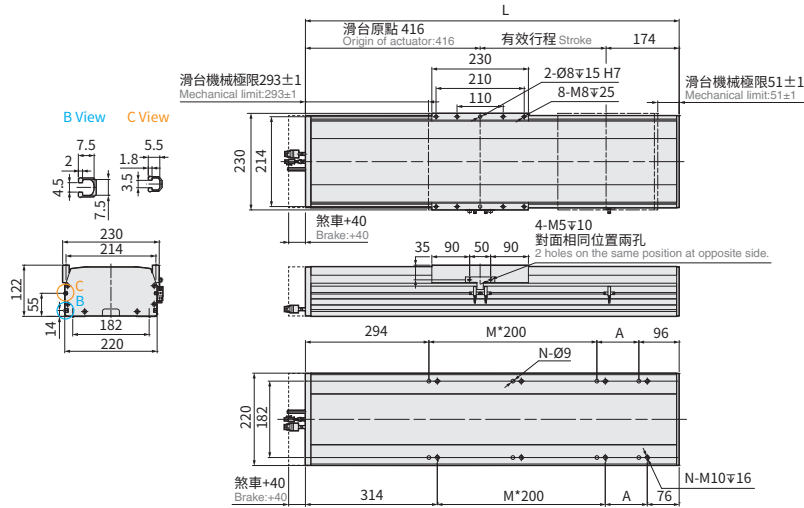

有效行程 Stroke	50	100	150	200	250	300	350	400	450	500	550	600	650	700	750	800	850	900	950	1000	1050	1100	1150	1200	1250	1300	1350	1400	1450	1500						
極限行程 Limit Stroke (±1)	66	116	166	216	266	316	366	416	466	516	566	616	666	716	766	816	866	916	966	1016	1066	1116	1166	1216	1266	1316	1366	1416	1466	1516						
L	640	690	740	790	840	890	940	990	1040	1090	1140	1190	1240	1290	1340	1390	1440	1490	1540	1590	1640	1690	1740	1790	1840	1890	1940	1990	2040	2090						
A	50	100	150	200	50	100	150	200	50	100	150	200	50	100	150	200	50	100	150	200	50	100	150	200	50	100	150	200	50	100						
M	1	1	1	1	2	2	2	2	3	3	3	3	4	4	4	4	5	5	5	5	6	6	6	6	7	7	7	7	8	8						
N	6	6	6	6	8	8	8	8	10	10	10	10	12	12	12	12	14	14	14	14	16	16	16	16	18	18	18	18	20	20						
KG	29.32	29.32	30.79	32.26	33.73	35.2	36.67	38.14	39.61	41.08	42.55	44.02	45.49	46.96	48.43	49.9	51.37	52.84	54.31	55.78	57.25	58.72	60.19	61.66	63.13	64.6	66.07	67.54	69.01	70.48						
線速度 Linear Speed mm/s	導程 Lead 5																	300											275	250	225	200	175	150	125	100
	導程 Lead 10																	600											550	500	450	400	350	300	250	200
	導程 Lead 25																	1500											1375	1250	1125	1000	875	750	625	500
	導程 Lead 40																	2400	2200	2000	1800	1600	1400	1200	1000	800	600									

BC 馬達外露 Motor Exposed



• CAD圖面可至www.toyorobot.com下載 •
Please download the CAD file from TOYO's website : www.toyorobot.com

單位 Unit : mm

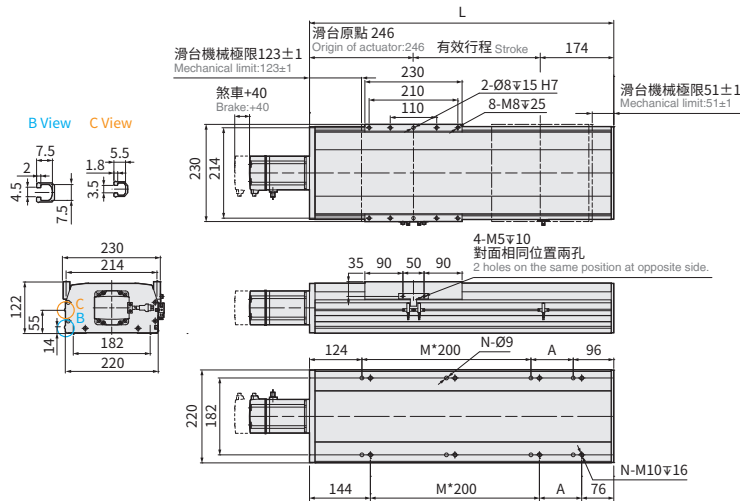

有效行程 Stroke	50	100	150	200	250	300	350	400	450	500	550	600	650	700	750	800	850	900	950	1000	1050	1100	1150	1200	1250	1300	1350	1400	1450	1500						
極限行程 Limit Stroke (±1)	66	116	166	216	266	316	366	416	466	516	566	616	666	716	766	816	866	916	966	1016	1066	1116	1166	1216	1266	1316	1366	1416	1466	1516						
L	470	520	570	620	670	720	770	820	870	920	970	1020	1070	1120	1170	1220	1270	1320	1370	1420	1470	1520	1570	1620	1670	1720	1770	1820	1870	1920						
A	50	100	150	200	50	100	150	200	50	100	150	200	50	100	150	200	50	100	150	200	50	100	150	200	50	100	150	200	50	100						
M	1	1	1	1	2	2	2	2	3	3	3	3	4	4	4	4	5	5	5	5	6	6	6	6	7	7	7	7	8	8						
N	6	6	6	6	8	8	8	8	10	10	10	10	12	12	12	12	14	14	14	14	16	16	16	16	18	18	18	18	20	20						
KG	25.4	26.86	28.32	29.78	31.24	32.7	34.16	35.62	37.08	38.54	40	41.46	42.92	44.38	45.84	47.3	48.76	50.22	51.68	53.14	54.6	56.06	57.52	58.98	60.44	61.9	63.36	64.82	66.28	67.74						
線速度 Linear Speed mm/s	導程 Lead 5																	300											275	250	225	200	175	150	125	100
	導程 Lead 10																	600											550	500	450	400	350	300	250	200
	導程 Lead 25																	1500											1375	1250	1125	1000	875	750	625	500
	導程 Lead 40																	2400	2200	2000	1800	1600	1400	1200	1000	800	600									

免費服務專線：大陸 400-875-0009 台灣 0800-800-893
 Toll-Free Number China Taiwan

應用例
Application

一般 / 螺桿仕様
ETH

一般 / 皮帶仕様
ETB / M

無塵 / 螺桿仕様
GCH / ECH

無塵 / 皮帶仕様
ECB

直交連結
XYGT / XYTH / XYTB

參考資料
Reference

BL 馬達左折 Motor Left Side



CAD圖面可至www.toyorobot.com下載
 Please download the CAD file from TOYO's website : www.toyorobot.com

單位 Unit : mm

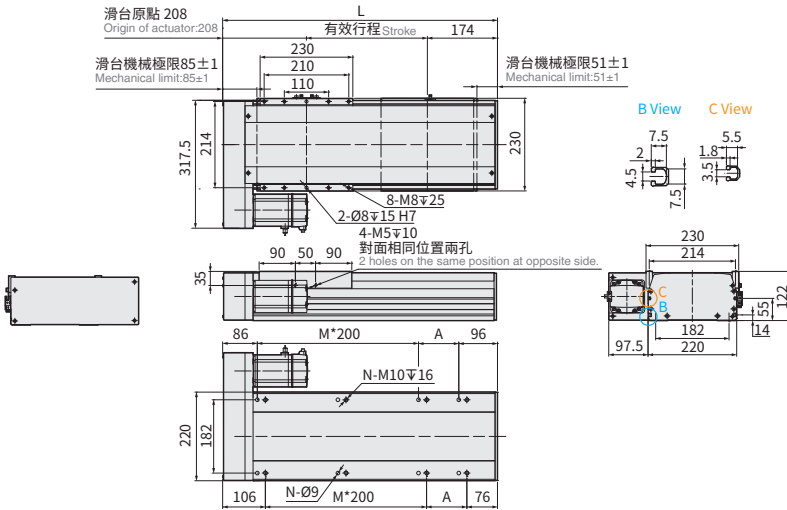

有效行程 Stroke	50	100	150	200	250	300	350	400	450	500	550	600	650	700	750	800	850	900	950	1000	1050	1100	1150	1200	1250	1300	1350	1400	1450	1500						
極限行程 Limit Stroke (±1)	66	116	166	216	266	316	366	416	466	516	566	616	666	716	766	816	866	916	966	1016	1066	1116	1166	1216	1266	1316	1366	1416	1466	1516						
L	432	482	532	582	632	682	732	782	832	882	932	982	1032	1082	1132	1182	1232	1282	1332	1382	1432	1482	1532	1582	1632	1682	1732	1782	1832	1882						
A	50	100	150	200	50	100	150	200	50	100	150	200	50	100	150	200	50	100	150	200	50	100	150	200	50	100	150	200	50	100						
M	1	1	1	1	2	2	2	2	3	3	3	3	4	4	4	4	5	5	5	5	6	6	6	6	7	7	7	7	8	8						
N	6	6	6	6	8	8	8	8	10	10	10	10	12	12	12	12	14	14	14	14	16	16	16	16	18	18	18	18	20	20						
KG	24.2	25.66	27.12	28.58	30.04	31.5	32.96	34.42	35.88	37.34	38.8	40.26	41.72	43.18	44.64	46.1	47.56	49.02	50.48	51.94	53.4	54.86	56.32	57.78	59.24	60.7	62.16	63.62	65.08	66.54						
線速度 Linear Speed mm/s	導程 Lead 5																	300											275	250	225	200	175	150	125	100
	導程 Lead 10																	600											550	500	450	400	350	300	250	200
	導程 Lead 25																	1500											1375	1250	1125	1000	875	750	625	500
	導程 Lead 40																	2400											2200	2000	1800	1600	1400	1200	1000	800

BR 馬達右折 Motor Right Side



CAD圖面可至www.toyorobot.com下載
 Please download the CAD file from TOYO's website : www.toyorobot.com

單位 Unit : mm

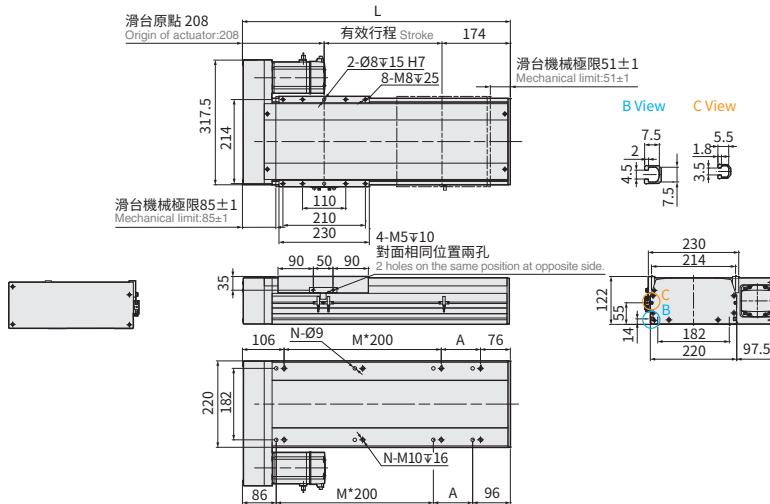

有效行程 Stroke	50	100	150	200	250	300	350	400	450	500	550	600	650	700	750	800	850	900	950	1000	1050	1100	1150	1200	1250	1300	1350	1400	1450	1500						
極限行程 Limit Stroke (±1)	66	116	166	216	266	316	366	416	466	516	566	616	666	716	766	816	866	916	966	1016	1066	1116	1166	1216	1266	1316	1366	1416	1466	1516						
L	432	482	532	582	632	682	732	782	832	882	932	982	1032	1082	1132	1182	1232	1282	1332	1382	1432	1482	1532	1582	1632	1682	1732	1782	1832	1882						
A	50	100	150	200	50	100	150	200	50	100	150	200	50	100	150	200	50	100	150	200	50	100	150	200	50	100	150	200	50	100						
M	1	1	1	1	2	2	2	2	3	3	3	3	4	4	4	4	5	5	5	5	6	6	6	6	7	7	7	7	8	8						
N	6	6	6	6	8	8	8	8	10	10	10	10	12	12	12	12	14	14	14	14	16	16	16	16	18	18	18	18	20	20						
KG	24.2	25.66	27.12	28.58	30.04	31.5	32.96	34.42	35.88	37.34	38.8	40.26	41.72	43.18	44.64	46.1	47.56	49.02	50.48	51.94	53.4	54.86	56.32	57.78	59.24	60.7	62.16	63.62	65.08	66.54						
線速度 Linear Speed mm/s	導程 Lead 5																	300											275	250	225	200	175	150	125	100
	導程 Lead 10																	600											550	500	450	400	350	300	250	200
	導程 Lead 25																	1500											1375	1250	1125	1000	875	750	625	500
	導程 Lead 40																	2400											2200	2000	1800	1600	1400	1200	1000	800

ETH Series

ETH13

ETH14

ETH17

ETH22

ETH17M

ETH22M

ETH22 單軸 /1-axis



BM 馬達下折 Motor Bottom Side



CAD圖面可至 www.toyorobot.com 下載
Please download the CAD file from TOYO's website : www.toyorobot.com

單位 Unit : mm

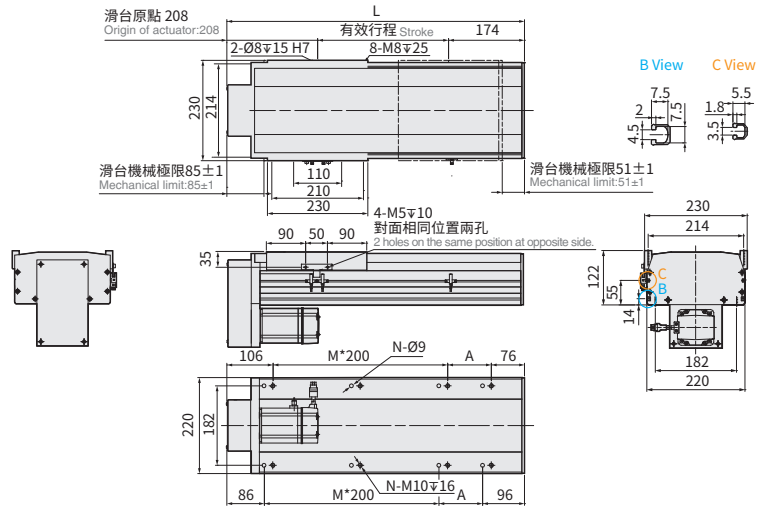

有效行程 Stroke	50	100	150	200	250	300	350	400	450	500	550	600	650	700	750	800	850	900	950	1000	1050	1100	1150	1200	1250	1300	1350	1400	1450	1500																																		
極限行程 Limit Stroke (± 1)	66	116	166	216	266	316	366	416	466	516	566	616	666	716	766	816	866	916	966	1016	1066	1116	1166	1216	1266	1316	1366	1416	1466	1516																																		
L	432	482	532	582	632	682	732	782	832	882	932	982	1032	1082	1132	1182	1232	1282	1332	1382	1432	1482	1532	1582	1632	1682	1732	1782	1832	1882																																		
A	50	100	150	200	50	100	150	200	50	100	150	200	50	100	150	200	50	100	150	200	50	100	150	200	50	100	150	200	50	100																																		
M	1	1	1	1	2	2	2	2	3	3	3	3	4	4	4	4	5	5	5	5	6	6	6	6	7	7	7	7	8	8																																		
N	6	6	6	6	8	8	8	8	10	10	10	10	12	12	12	12	14	14	14	14	16	16	16	16	18	18	18	18	20	20																																		
KG	24.2	25.66	27.12	28.58	30.04	31.5	32.96	34.42	35.88	37.34	38.8	40.26	41.72	43.18	44.64	46.1	47.56	49.02	50.48	51.94	53.4	54.86	56.32	57.78	59.24	60.7	62.16	63.62	65.08	66.54																																		
線速度 Linear Speed mm/s	導程 Lead 5																300																																															
	導程 Lead 10																600																																															
	導程 Lead 25																1500																																															
	導程 Lead 40																2400																																															
																2200						2000						1800						1600						1400						1200						1000						800						600

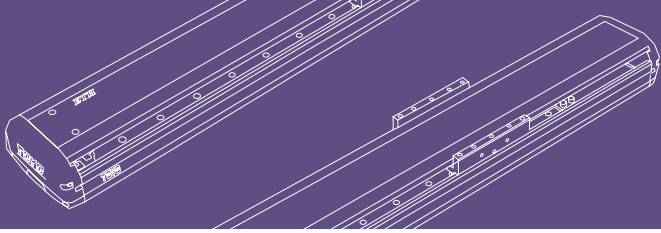

免費服務專線：大陸 400-875-0009 台灣 0800-800-893
Toll-Free Number China Taiwan

應用例
Application

一般 / 螺桿仕様
ETH

一般 / 皮帶仕様
ETB / M

無塵 / 螺桿仕様
GCH / ECH

無塵 / 皮帶仕様
ECB

直交連結
XYGT / XTH / XYTB

參考資料
Reference

Memo

ETH Series

ETH13

ETH14

ETH17

ETH22

ETH17M

ETH22M

ETH17M 單軸 /1-axis

▶ 螺桿驅動
Ball Screw Drive

精度
±0.005 mm

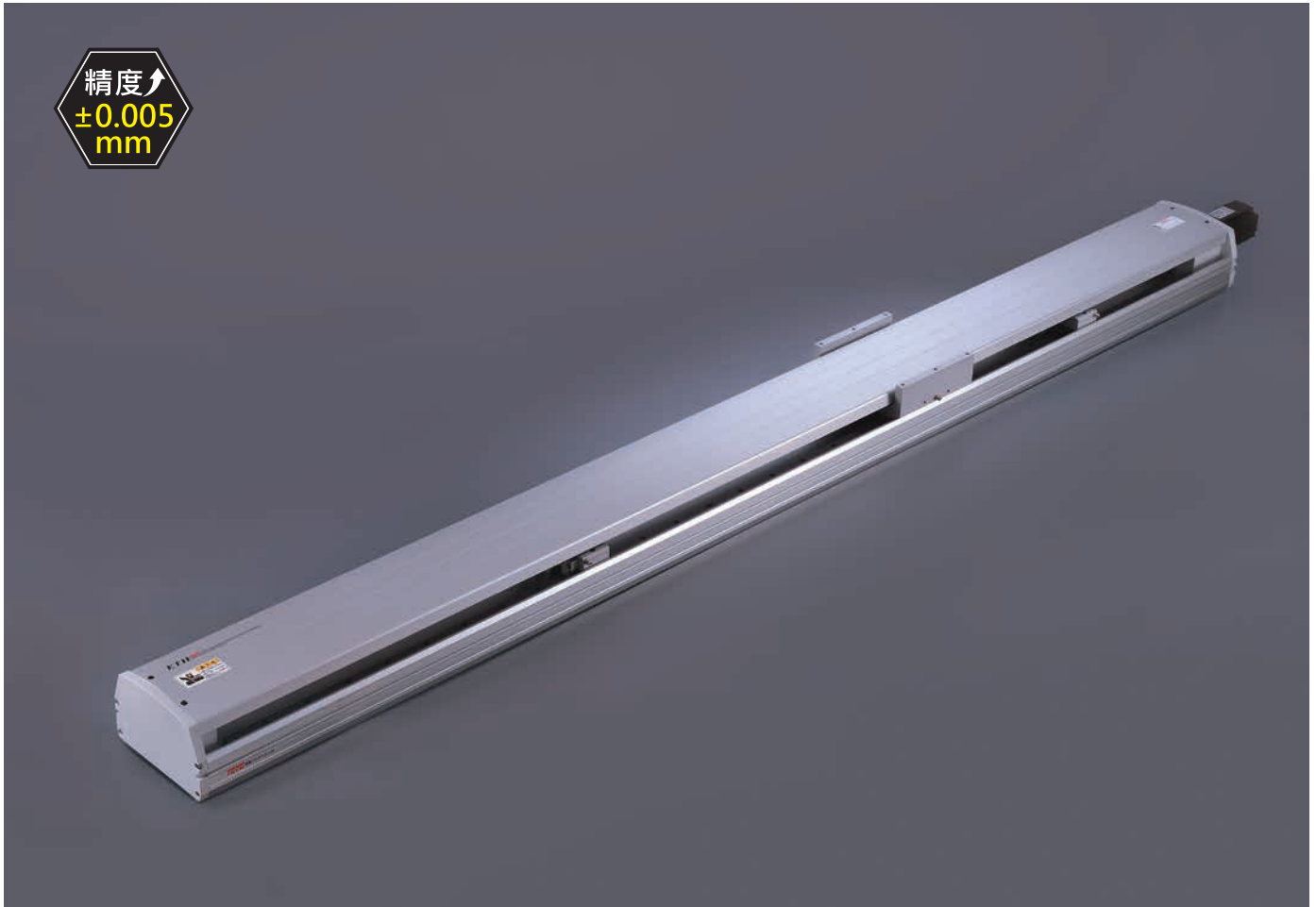

- 最大行程 Maximum Stroke: 2200mm
- 最高速度 Maximum Speed: 1920mm/s
- 馬達容量 Motor Output: 400W
- 滾珠螺桿 Ball Screw: ø16mm
- 直線滑軌 Linear Guide: 15X12.5-2 支

型號表示方式 Ordering Method

ETH17M - L5 - 800 - M - M40B - C4N5 - 參照右頁
Refer to the right page. - 0001

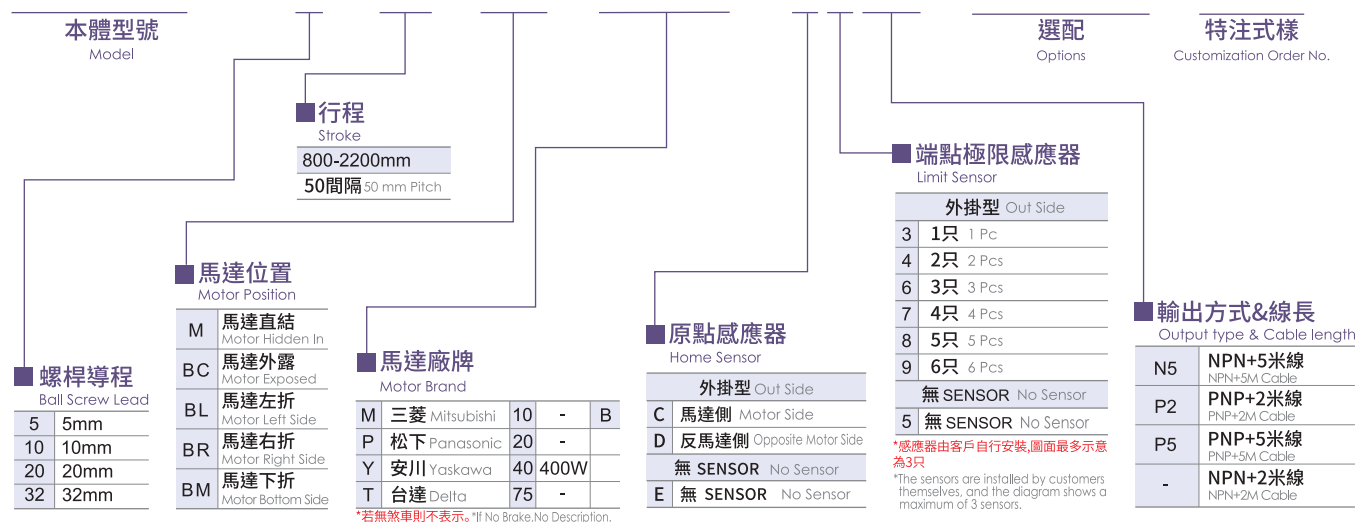

基本仕様 Specification

性能	位置重複精度 Repeatability	mm	±0.005				
	螺桿導程 Lead	mm	5	10	20	32	
	最高轉速 Maximum Rotating speed	rpm	3600	3600	3600	3600	
	最高速度 Maximum linear speed ※1	mm/s	300	600	1200	1920	
	最大可搬重量 Maximum Payload	水平使用 Horizontal	kg	110	90	40	30
		垂直使用 Vertical	kg	33	22	10	8
	定格推力 Rated Thrust	N	1388	694	347	218	
部品	標準行程 Stroke (increments)	mm	800-2200mm/50 間隔 (50 increments)				
	AC 伺服馬達容量 AC Servo Motor Output	W	400				
	滾珠螺桿外徑 Ball Screw ϕ	mm	C7 ϕ 16				
	高剛性直線滑軌 High Rigidity Linear Guide	mm	W15XH12.5				
	連軸器 Coupling	mm	10X14				
	原點感應器 Home Sensor	外掛 Outside	T62N2 (NPN+2 米線) (NPN+2M Cable)				

※1 長行程時，會產生螺桿偏擺，需將速度調降 (線速度請參閱尺寸圖下方表格)

During in a long stroke, it causes ballscrew deflection, the speed must reduce. (Please refer to the linear velocity from the data sheet below the dimension graph.)

容許負載力距表 Allowable Overhang

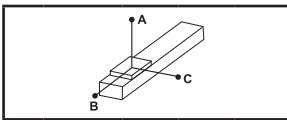

(單位 Unit : mm)

水平安裝 Horizontal Installation		A	B	C
導程 5 Lead	70kg	1701	158	200
	90kg	1261	114	144
	110kg	980	86	109
導程 10 Lead	60kg	882	164	194
	75kg	678	123	146
	90kg	541	96	114
導程 20 Lead	20kg	1081	422	425
	30kg	698	268	271
	40kg	507	191	194
導程 32 Lead	10kg	934	589	494
	20kg	446	274	232
	30kg	283	169	145

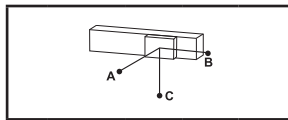

(單位 Unit : mm)

壁掛安裝 Wall Installation		A	B	C
導程 5 Lead	70kg	200	158	1701
	90kg	144	114	1261
	110kg	109	86	980
導程 10 Lead	60kg	194	164	882
	75kg	146	123	678
	90kg	114	96	541
導程 20 Lead	20kg	425	422	1081
	30kg	271	268	698
	40kg	194	191	507
導程 32 Lead	10kg	494	589	934
	20kg	232	274	446
	30kg	145	169	283

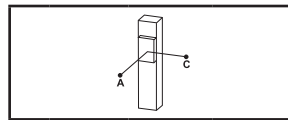

(單位 Unit : mm)

垂直安裝 Vertical Installation		A	C
導程 5 Lead	15kg	918	918
	22kg	626	626
	33kg	417	417
導程 10 Lead	10kg	1196	1196
	16kg	747	747
	22kg	543	543
導程 20 Lead	5kg	1686	1686
	7kg	1204	1204
	10kg	843	843
導程 32 Lead	3kg	1717	1717
	5kg	1030	1030
	8kg	644	644

靜額定扭矩 Static Loading Moment

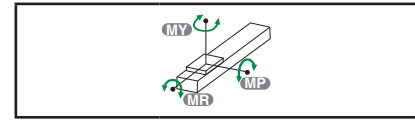

(單位 Unit : N.m)

MY	552
MP	552
MR	638

* 力矩表所表示的數據，代表荷重的重心位置於單一方向容許懸出的長度。
 The data represented by the moment table is the center of gravity of the load. The length of the overhang is allowed in a single direction.
 * 符合型錄規範的正常使用下，保證壽命為 10000 公里。
 Operation life is 10,000km when the product is using under the specified conditions.
 * 倒吊使用無法套用標準規範，如有需求請洽詢我司業務。
 Data information is not for ceiling-mount inverse use. Contact us for the details if you want to apply ceiling-mount inverse usage.
 * 壽命及力矩是以馬達加減速設定 0.2 秒計算。
 The life and torque are calculated by setting the motor acceleration and deceleration for 0.2 seconds.

選配 Options

NL		P		EB		MM		CMK								
外拉式注油嘴位置 External oil injection nozzle position		標準 PIN 孔 Standard PIN hole		外觀黑色處理 Outer layer is treated with black oxide		指定馬達出線方向 Selectable Cable Leading Direction		馬達傳動配件追加鍵槽 Additional keyway for motor drive parts								
代號 Code	說明 Instructions	需參照 Refer to	代號 Code	說明 Instructions	需參照 Refer to	代號 Code	說明 Instructions	代號 Code	說明 Instructions	代號 Code	說明 Instructions	代號 Code	說明 Instructions	需參照 Refer to		
NL	滑座右側 On The Right of The Slider	P.675 ~ P.676	P	標準 PIN 孔 Standard PIN hole	P.677	EB	黑色 Black	MW	朝上 Upper side	P.679 ~ P.680	CMK	SKY	單邊 (限定馬達側) Single (Limited to the motor side)	BC/M	鍵槽式聯軸器 Keyway Coupling	P.681 ~ P.682
NR	滑座右側 On The Right of The Slider		EB	原色 Original color		MM	朝下 Bottom side	BL/BR/BM	鍵槽式皮帶輪 Keyway Belt Pulley							
NRL	滑座雙邊注油 Slide both sides for oil injection		EB	不銹鋼板材 Stainless steel plate 螺絲 Screw		ML	朝左 Left side	不適用 Not Applicable								
		EB		MR	朝右 Right side	不適用 Not Applicable										
												SKN	雙邊 Double	BC/M	無聯軸器 (請自行購買安裝) Without Coupling (Please purchase and install by yourself)	
														BL/BR/BM	不適用 Not Applicable	

ETH17M 單軸 /1-axis



M 馬達直結 Motor Hidden In



• CAD圖面可至www.toyorobot.com下載 •
Please download the CAD file from TOYO's website : www.toyorobot.com

單位 Unit : mm

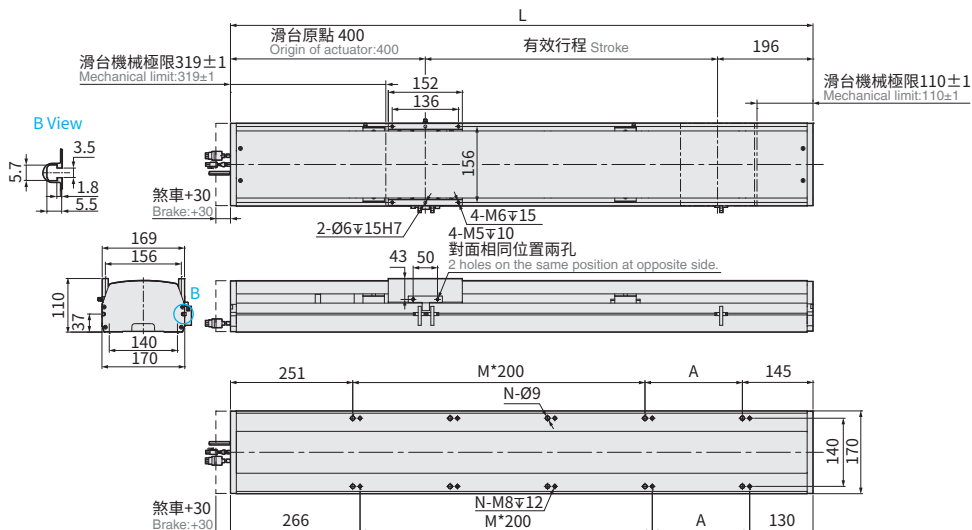

有效行程 Stroke	800	850	900	950	1000	1050	1100	1150	1200	1250	1300	1350	1400	1450	1500	1550	1600	1650	1700	1750	1800	1850	1900	1950	2000	2050	2100	2150	2200																															
極限行程 Limit Stroke (±1)	815	865	915	965	1015	1065	1115	1165	1215	1265	1315	1365	1415	1465	1515	1565	1615	1665	1715	1765	1815	1865	1915	1965	2015	2065	2115	2165	2215																															
L	1396	1446	1496	1546	1596	1646	1696	1746	1796	1846	1896	1946	1996	2046	2096	2146	2196	2246	2296	2346	2396	2446	2496	2546	2596	2646	2696	2746	2796																															
A	200	50	100	150	200	50	100	150	200	50	100	150	200	50	100	150	200	50	100	150	200	50	100	150	200	50	100	150	200																															
M	4	5	5	5	5	6	6	6	6	7	7	7	7	8	8	8	8	9	9	9	9	10	10	10	10	11	11	11	11																															
N	12	14	14	14	14	16	16	16	16	18	18	18	18	20	20	20	20	22	22	22	22	24	24	24	24	26	26	26	26																															
KG	29.88	30.56	31.24	31.92	32.6	33.28	33.96	34.64	35.32	36	36.68	37.36	38.04	38.72	39.4	40.08	40.76	41.44	42.12	42.8	43.48	44.16	44.84	45.52	46.2	46.88	47.56	48.24	48.92																															
線速度 Linear Speed mm/s	導程 Lead 5																300												283	267	250	233	217	200	183	175												150												125
	導程 Lead 10																600												567	533	500	467	433	400	367	350												300												250
	導程 Lead 20																1200												1133	1067	1000	933	867	800	733	700												600												500
	導程 Lead 32																1920												1813	1707	1600	1493	1387	1280	1173	1120												960												800

BC 馬達外露 Motor Exposed



• CAD圖面可至www.toyorobot.com下載 •
Please download the CAD file from TOYO's website : www.toyorobot.com

單位 Unit : mm

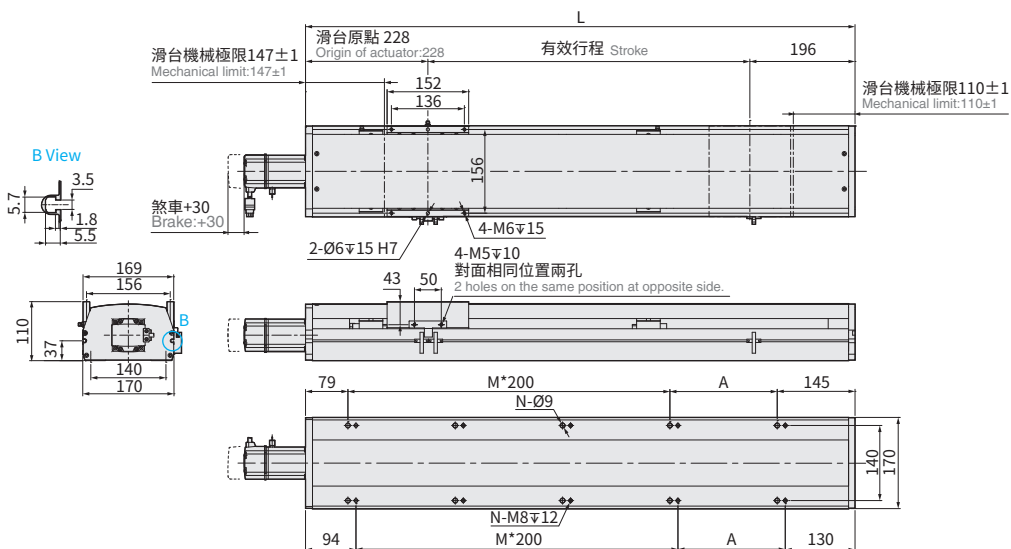

有效行程 Stroke	800	850	900	950	1000	1050	1100	1150	1200	1250	1300	1350	1400	1450	1500	1550	1600	1650	1700	1750	1800	1850	1900	1950	2000	2050	2100	2150	2200																															
極限行程 Limit Stroke (±1)	815	865	915	965	1015	1065	1115	1165	1215	1265	1315	1365	1415	1465	1515	1565	1615	1665	1715	1765	1815	1865	1915	1965	2015	2065	2115	2165	2215																															
L	1224	1274	1324	1374	1424	1474	1524	1574	1624	1674	1724	1774	1824	1874	1924	1974	2024	2074	2124	2174	2224	2274	2324	2374	2424	2474	2524	2574	2624																															
A	200	50	100	150	200	50	100	150	200	50	100	150	200	50	100	150	200	50	100	150	200	50	100	150	200	50	100	150	200																															
M	4	5	5	5	5	6	6	6	6	7	7	7	7	8	8	8	8	9	9	9	9	10	10	10	10	10	11	11	11	11																														
N	12	14	14	14	14	16	16	16	16	18	18	18	18	20	20	20	20	22	22	22	22	24	24	24	24	26	26	26	26																															
KG	28.99	29.67	30.35	31.03	31.71	32.39	33.07	33.75	34.43	35.11	35.79	36.47	37.15	37.83	38.51	39.19	39.87	40.55	41.23	41.91	42.59	43.27	43.95	44.63	45.31	45.99	46.67	47.35	48.03																															
線速度 Linear Speed mm/s	導程 Lead 5																300												283	267	250	233	217	200	183	175												150												125
	導程 Lead 10																600												567	533	500	467	433	400	367	350												300												250
	導程 Lead 20																1200												1133	1067	1000	933	867	800	733	700												600												500
	導程 Lead 32																1920												1813	1707	1600	1493	1387	1280	1173	1120												960												800

免費服務專線：大陸 400-875-0009 台灣 0800-800-893
 Toll-Free Number China Taiwan

應用例
Application

一般 / 螺桿仕様
ETH

一般 / 皮帶仕様
ETB / M

無塵 / 螺桿仕様
GCH / ECH

無塵 / 皮帶仕様
ECB

直交連結
XYGT / XYTH / XYTB

參考資料
Reference

BL 馬達左折 Motor Left Side



● CAD圖面可至www.toyorobot.com下載 ●

Please download the CAD file from TOYO's website : www.toyorobot.com

單位 Unit : mm

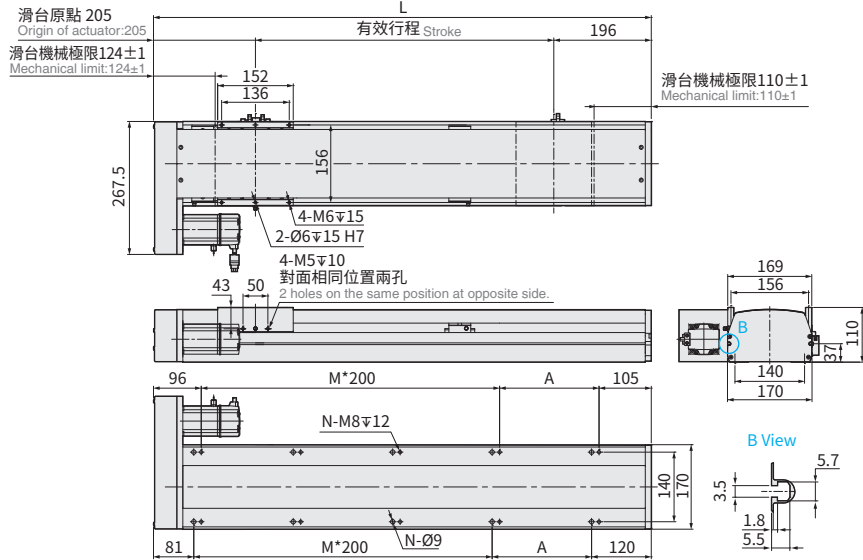

有效行程 Stroke	800	850	900	950	1000	1050	1100	1150	1200	1250	1300	1350	1400	1450	1500	1550	1600	1650	1700	1750	1800	1850	1900	1950	2000	2050	2100	2150	2200																					
極限行程 Limit Stroke (±1)	815	865	915	965	1015	1065	1115	1165	1215	1265	1315	1365	1415	1465	1515	1565	1615	1665	1715	1765	1815	1865	1915	1965	2015	2065	2115	2165	2215																					
L	1201	1251	1301	1351	1401	1451	1501	1551	1601	1651	1701	1751	1801	1851	1901	1951	2001	2051	2101	2151	2201	2251	2301	2351	2401	2451	2501	2551	2601																					
A	200	50	100	150	200	50	100	150	200	50	100	150	200	50	100	150	200	50	100	150	200	50	100	150	200	50	100	150	200																					
M	4	5	5	5	5	6	6	6	6	7	7	7	7	8	8	8	8	9	9	9	9	10	10	10	10	11	11	11	11																					
N	12	14	14	14	14	16	16	16	16	18	18	18	18	20	20	20	20	22	22	22	22	24	24	24	24	26	26	26	26																					
KG	29.86	30.54	31.22	31.9	32.58	33.26	33.94	34.62	35.3	35.98	36.66	37.34	38.02	38.7	39.38	40.06	40.74	41.42	42.1	42.78	43.46	44.14	44.82	45.5	46.18	46.86	47.54	48.22	48.9																					
線速度 Linear Speed mm/s	導程 Lead 5	300																									283	267	250	233	217	200	183	175										150	125					
	導程 Lead 10	600																									567	533	500	467	433	400	367	350										300	250					
	導程 Lead 20	1200																									1133	1067	1000	933	867	800	733	700										600	500					
	導程 Lead 32	1920																									1813	1707	1600	1493	1387	1280	1173										1120	960						

BR 馬達右折 Motor Right Side



● CAD圖面可至www.toyorobot.com下載 ●

Please download the CAD file from TOYO's website : www.toyorobot.com

單位 Unit : mm

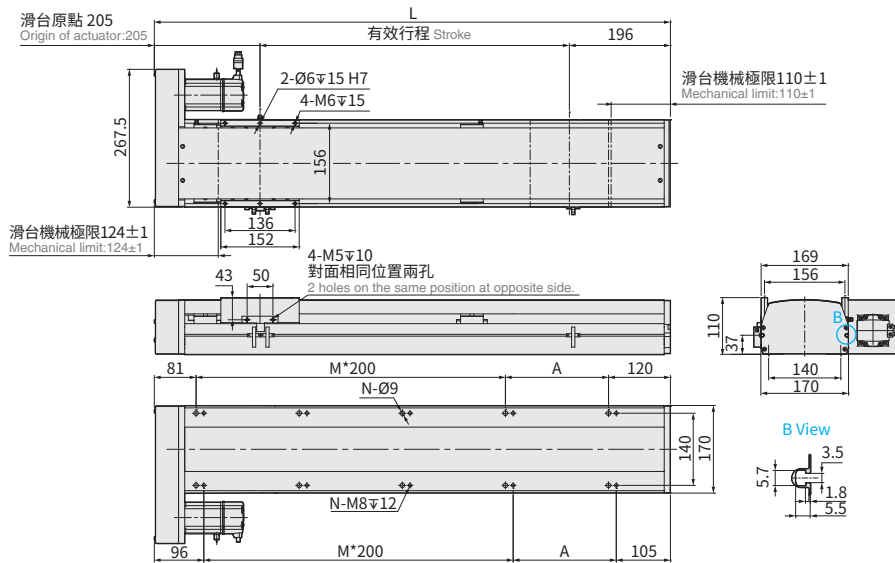

有效行程 Stroke	800	850	900	950	1000	1050	1100	1150	1200	1250	1300	1350	1400	1450	1500	1550	1600	1650	1700	1750	1800	1850	1900	1950	2000	2050	2100	2150	2200																					
極限行程 Limit Stroke (±1)	815	865	915	965	1015	1065	1115	1165	1215	1265	1315	1365	1415	1465	1515	1565	1615	1665	1715	1765	1815	1865	1915	1965	2015	2065	2115	2165	2215																					
L	1201	1251	1301	1351	1401	1451	1501	1551	1601	1651	1701	1751	1801	1851	1901	1951	2001	2051	2101	2151	2201	2251	2301	2351	2401	2451	2501	2551	2601																					
A	200	50	100	150	200	50	100	150	200	50	100	150	200	50	100	150	200	50	100	150	200	50	100	150	200	50	100	150	200																					
M	4	5	5	5	5	6	6	6	6	7	7	7	7	8	8	8	8	9	9	9	9	10	10	10	10	10	11	11	11																					
N	12	14	14	14	14	16	16	16	16	18	18	18	18	20	20	20	20	22	22	22	22	24	24	24	24	26	26	26	26																					
KG	29.86	30.54	31.22	31.9	32.58	33.26	33.94	34.62	35.3	35.98	36.66	37.34	38.02	38.7	39.38	40.06	40.74	41.42	42.1	42.78	43.46	44.14	44.82	45.5	46.18	46.86	47.54	48.22	48.9																					
線速度 Linear Speed mm/s	導程 Lead 5	300																									283	267	250	233	217	200	183	175										150	125					
	導程 Lead 10	600																									567	533	500	467	433	400	367	350										300	250					
	導程 Lead 20	1200																									1133	1067	1000	933	867	800	733	700										600	500					
	導程 Lead 32	1920																									1813	1707	1600	1493	1387	1280	1173										1120	960						

ETH Series

ETH13

ETH14

ETH17

ETH22

ETH17M

ETH22M

ETH17M 單軸 /1-axis

BM 馬達下折 Motor Bottom Side



CAD圖面可至 www.toyorobot.com 下載
Please download the CAD file from TOYO's website : www.toyorobot.com

單位 Unit : mm

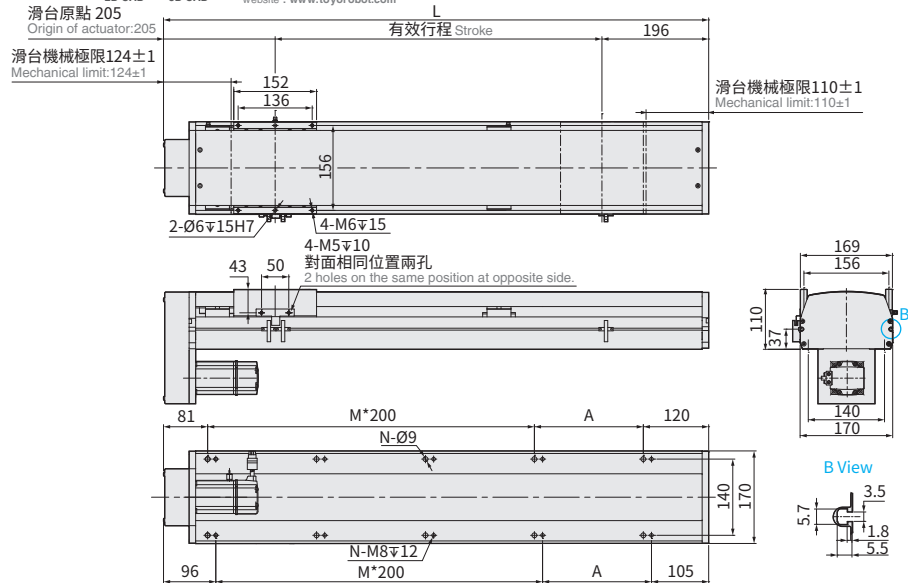

有效行程 Stroke	800	850	900	950	1000	1050	1100	1150	1200	1250	1300	1350	1400	1450	1500	1550	1600	1650	1700	1750	1800	1850	1900	1950	2000	2050	2100	2150	2200																																
極限行程 Limit Stroke (±1)	815	865	915	965	1015	1065	1115	1165	1215	1265	1315	1365	1415	1465	1515	1565	1615	1665	1715	1765	1815	1865	1915	1965	2015	2065	2115	2165	2215																																
L	1201	1251	1301	1351	1401	1451	1501	1551	1601	1651	1701	1751	1801	1851	1901	1951	2001	2051	2101	2151	2201	2251	2301	2351	2401	2451	2501	2551	2601																																
A	200	50	100	150	200	50	100	150	200	50	100	150	200	50	100	150	200	50	100	150	200	50	100	150	200	50	100	150	200																																
M	4	5	5	5	5	6	6	6	6	7	7	7	7	8	8	8	8	9	9	9	9	10	10	10	10	11	11	11	11																																
N	12	14	14	14	14	16	16	16	16	18	18	18	18	20	20	20	20	22	22	22	22	24	24	24	24	26	26	26	26																																
KG	29.86	30.54	31.22	31.9	32.58	33.26	33.94	34.62	35.3	35.98	36.66	37.34	38.02	38.7	39.38	40.06	40.74	41.42	42.1	42.78	43.46	44.14	44.82	45.5	46.18	46.86	47.54	48.22	48.9																																
線速度 Linear Speed mm/s	導程 Lead 5						300					283					267					250					233					217					200					183					175					150					125				
	導程 Lead 10						600					567					533					500					467					433					400					367					350					300					250				
	導程 Lead 20						1200					1133					1067					1000					933					867					800					733					700					600					500				
	導程 Lead 32						1920					1813					1707					1600					1493					1387					1280					1173					1120					960					800				

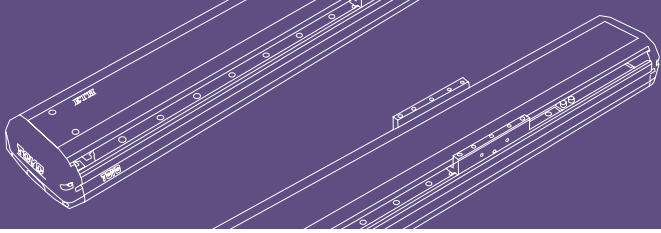

免費服務專線：大陸 400-875-0009 台灣 0800-800-893
Toll-Free Number China Taiwan

應用例
Application

一般 / 螺桿仕様
ETH

一般 / 皮帶仕様
ETB / M

無塵 / 螺桿仕様
GCH / ECH

無塵 / 皮帶仕様
ECB

直交連結
XYGT / XTH / XYTB

參考資料
Reference

Memo

ETH Series

ETH13

ETH14

ETH17

ETH22

ETH17M

ETH22M

ETH17M 單軸 /1-axis

▶ 螺桿驅動
Ball Screw Drive

精度
±0.005 mm

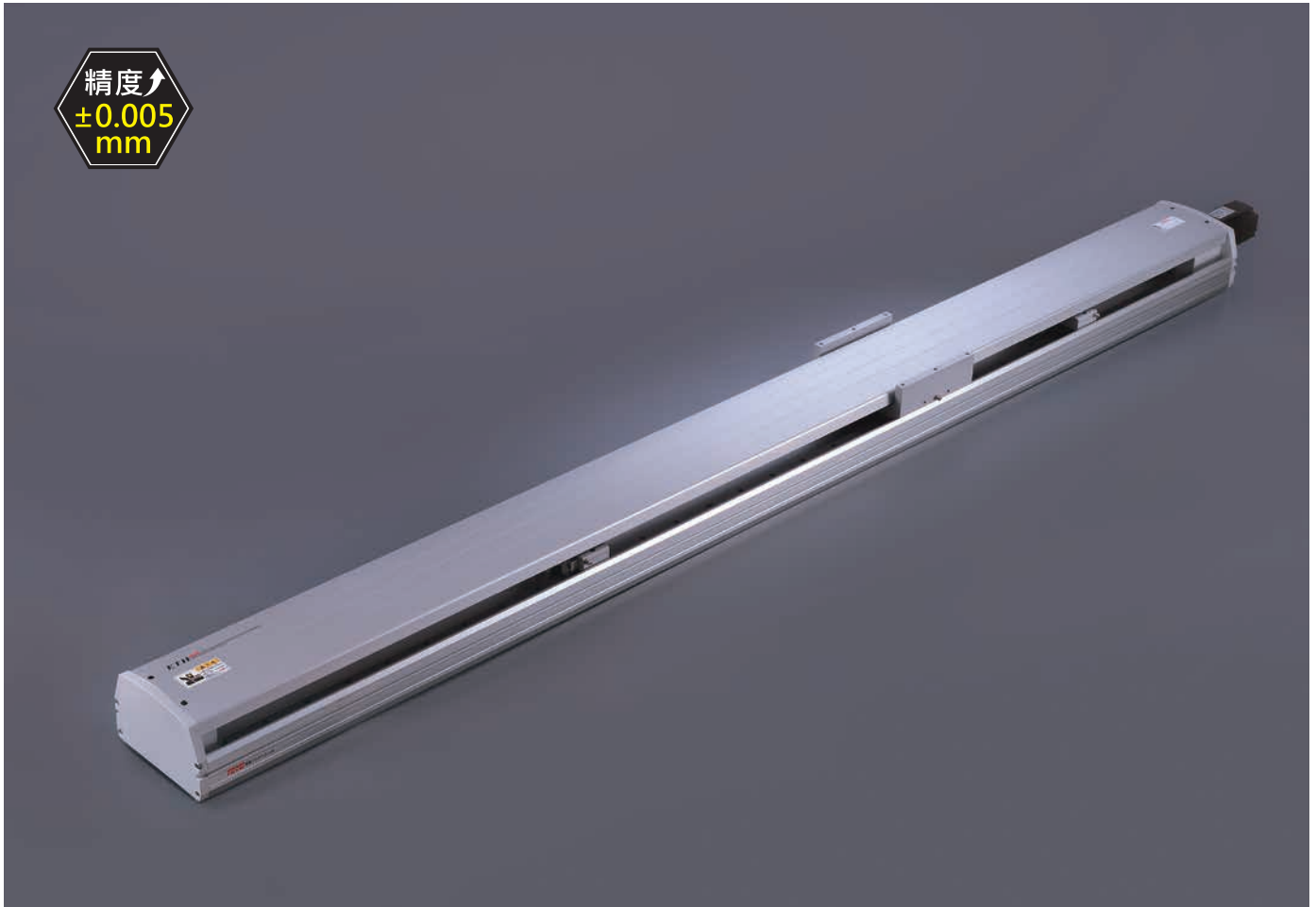

最大行程 2200mm (Maximum Stroke) | 最高速度 1920mm/s (Maximum Speed) | 馬達容量 750W (Motor Output) | 滾珠螺桿 ø16mm (Ball Screw) | 直線滑軌 15X12.5-2支 (Linear Guide)

型號表示方式 Ordering Method

ETH17M - L5 - 800 - BC - M75B - C4N5 - 參照右頁
Refer to the right page. - 0001

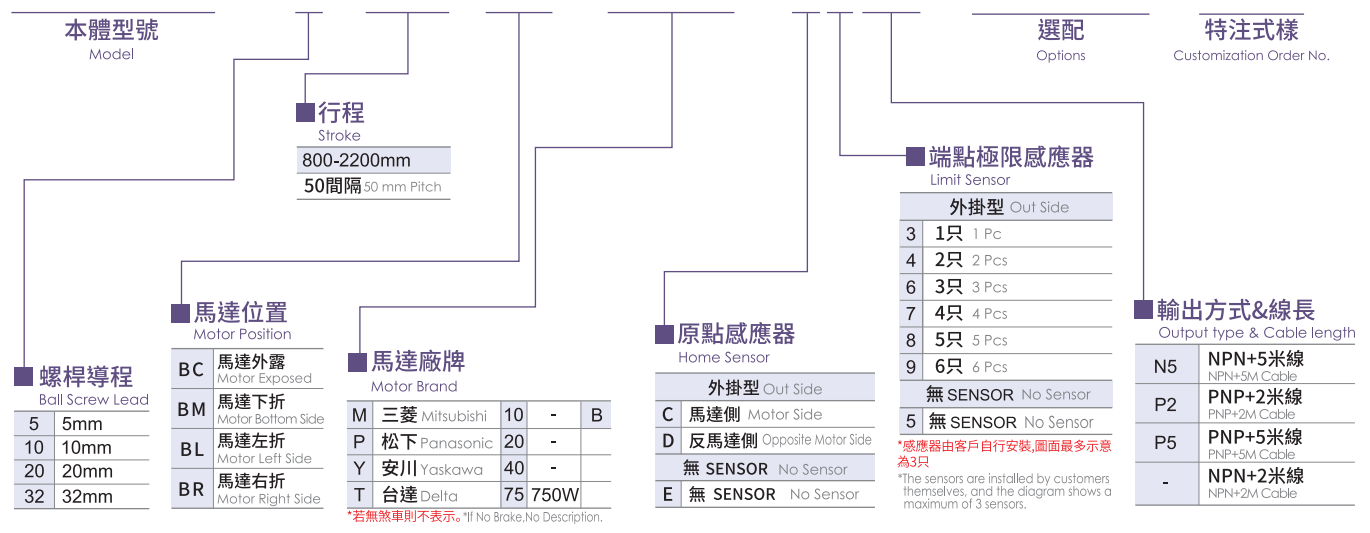

基本仕様 Specification

性能	位置重複精度 Repeatability	mm	±0.005				
	螺桿導程 Lead	mm	5	10	20	32	
	最高轉速 Maximum Rotating speed	rpm	3600	3600	3600	3600	
	最高速度 Maximum linear speed *1	mm/s	300	600	1200	1920	
	最大可搬重量 Maximum Payload	水平使用 Horizontal	kg	120	95	50	35
		垂直使用 Vertical	kg	40	25	15	12
	定格推力 Rated Thrust	N	2563	1281	640	400	
部品	標準行程 Stroke (increments)	mm	800-2200mm/50 間隔 (50 increments)				
	AC 伺服馬達容量 AC Servo Motor Output	W	750				
	滾珠螺桿外徑 Ball Screw Ø	mm	C7Ø16				
	高剛性直線滑軌 High Rigidity Linear Guide	mm	W15XH12.5				
	連軸器 Coupling	mm	10X19				
	原點感應器 Home Sensor	外掛 Outside	T62N2 (NPN+2 米線) (NPN+2M Cable)				

*1 長行程時，會產生螺桿偏擺，需將速度調降 (線速度請參閱尺寸圖下方表格)

During in a long stroke, it causes ballscrew deflection, the speed must reduce. (Please refer to the linear velocity from the data sheet below the dimension graph.)

容許負載力距表 Allowable Overhang

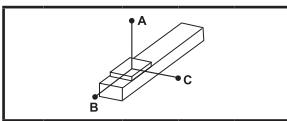

(單位 Unit : mm)

水平安裝 Horizontal Installation		A	B	C
導程 5 Lead	70kg	1701	158	200
	90kg	1261	114	144
	120kg	874	75	95
導程 10 Lead	60kg	882	164	194
	75kg	678	123	146
	95kg	505	89	105
導程 20 Lead	20kg	1081	422	425
	30kg	698	268	271
	50kg	392	145	147
導程 32 Lead	10kg	934	589	494
	20kg	446	274	232
	35kg	237	139	120

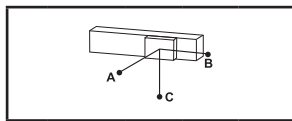

(單位 Unit : mm)

壁掛安裝 Wall Installation		A	B	C
導程 5 Lead	70kg	200	158	1701
	90kg	144	114	1261
	120kg	95	75	874
導程 10 Lead	60kg	194	164	882
	75kg	146	123	678
	95kg	105	89	505
導程 20 Lead	20kg	425	422	1081
	30kg	271	268	698
	50kg	147	145	392
導程 32 Lead	10kg	494	589	934
	20kg	232	274	446
	35kg	120	139	237

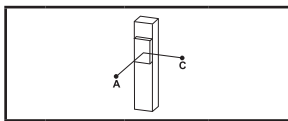

(單位 Unit : mm)

垂直安裝 Vertical Installation		A	C
導程 5 Lead	15kg	918	918
	22kg	626	626
	40kg	344	344
導程 10 Lead	10kg	1196	1196
	14kg	854	854
	25kg	478	478
導程 20 Lead	7kg	1204	1204
	10kg	843	843
	15kg	562	562
導程 32 Lead	5kg	1030	1030
	8kg	644	644
	12kg	429	429

靜額定扭矩 Static Loading Moment

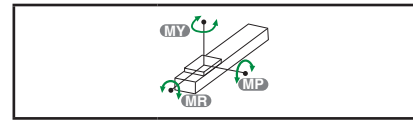

(單位 Unit : N.m)

MY	552
MP	552
MR	638

* 力矩表所表示的數據，代表荷重的重心位置於單一方向容許懸出的長度。
 The data represented by the moment table is the center of gravity of the load. The length of the overhang is allowed in a single direction.
 * 符合型錄規範的正常使用下，保證壽命為 10000 公里。
 Operation life is 10,000km when the product is using under the specified conditions.
 * 倒吊使用無法套用標準規範，如有需求請洽詢我司業務。
 Data information is not for ceiling-mount inverse use. Contact us for the details if you want to apply ceiling-mount inverse usage.
 * 壽命及力矩是以馬達加速減速設定 0.2 秒計算。
 The life and torque are calculated by setting the motor acceleration and deceleration for 0.2 seconds.

選配 Options

NL		P		EB		MM		CMK							
外拉式注油嘴位置 External oil injection nozzle position		標準 PIN 孔 Standard PIN hole		外觀黑色處理 Outer layer is treated with black oxide		指定馬達出線方向 Selectable Cable Leading Direction		馬達傳動配件追加鍵槽 Additional keyway for motor drive parts							
代號 Code	說明 Instructions	需參照 Refer to	代號 Code	說明 Instructions	需參照 Refer to	代號 Code	說明 Instructions	代號 Code	說明 Instructions	需參照 Refer to					
NL	滑座右側 On The Right of The Slider	P.675 ~ P.676	P	標準 PIN 孔 Standard PIN hole	P.677	EB	黑色 Black	MW	朝上 Upper side	P.679 ~ P.680	CMK	單邊 (限定馬達側) Single (Limited to the motor side)	BC	鍵槽式聯軸器 Keyway Coupling	P.681 ~ P.682
NR	滑座右側 On The Right of The Slider		EB	原色 Original color		MM	朝下 Bottom side	CMK	BL/BR/BM		鍵槽式皮帶輪 Keyway Belt Pulley				
NRL	滑座雙邊注油 Slide both sides for oil injection		EB	不銹鋼板材 Stainless steel plate 螺絲 Screw		ML	朝左 Left side	SKY	雙邊 Double		BC	鍵槽式聯軸器 Keyway Coupling			
		MR	朝右 Right side	SKN	雙邊 Double	BL/BR/BM	不適用 Not Applicable	BC	無聯軸器 (請自行購買安裝) Without Coupling (Please purchase and install by yourself)						
									BL/BR/BM	不適用 Not Applicable					

ETH17M 單軸 /1-axis



BC 馬達外露 Motor Exposed



• CAD圖面可至www.toyorobot.com下載 •
Please download the CAD file from TOYO's website : www.toyorobot.com

單位 Unit : mm

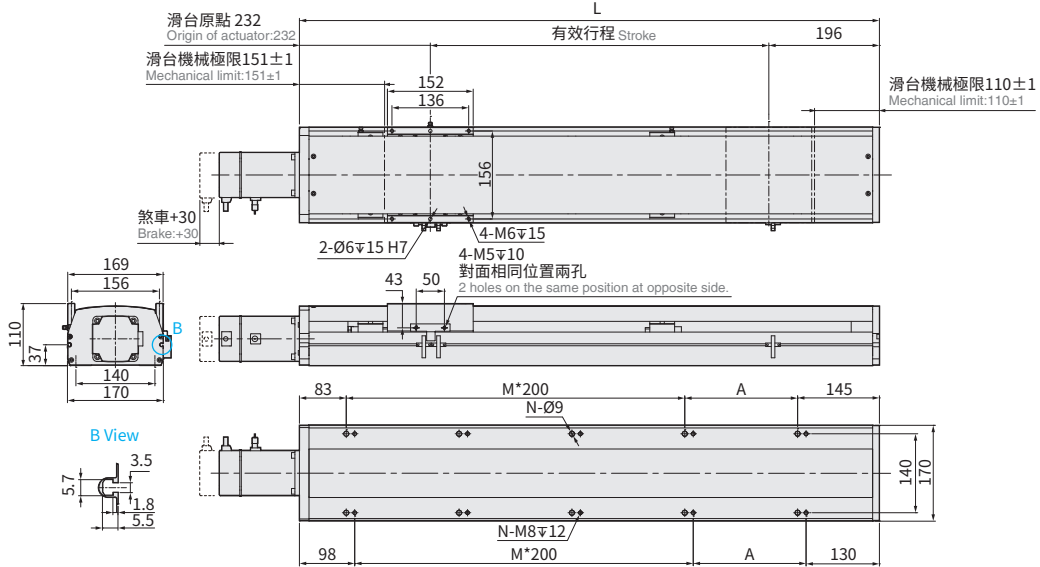

有效行程 Stroke	800	850	900	950	1000	1050	1100	1150	1200	1250	1300	1350	1400	1450	1500	1550	1600	1650	1700	1750	1800	1850	1900	1950	2000	2050	2100	2150	2200																							
極限行程 Limit Stroke (±1)	815	865	915	965	1015	1065	1115	1165	1215	1265	1315	1365	1415	1465	1515	1565	1615	1665	1715	1765	1815	1865	1915	1965	2015	2065	2115	2165	2215																							
L	1228	1278	1328	1378	1428	1478	1528	1578	1628	1678	1728	1778	1828	1878	1928	1978	2028	2078	2128	2178	2228	2278	2328	2378	2428	2478	2528	2578	2628																							
A	200	50	100	150	200	50	100	150	200	50	100	150	200	50	100	150	200	50	100	150	200	50	100	150	200	50	100	150	200																							
M	4	5	5	5	5	6	6	6	6	7	7	7	7	8	8	8	8	9	9	9	9	10	10	10	10	11	11	11	11																							
N	12	14	14	14	14	16	16	16	16	18	18	18	18	20	20	20	20	22	22	22	22	24	24	24	24	26	26	26	26																							
KG	29.74	30.42	31.1	31.78	32.46	33.14	33.82	34.5	35.18	35.86	36.54	37.22	37.9	38.58	39.26	39.94	40.62	41.3	41.98	42.66	43.34	44.02	44.7	45.38	46.06	46.74	47.42	48.1	48.78																							
線速度 Linear Speed mm/s	導程 Lead 5																300											283	267	250	233	217	200	183						175						150						125
	導程 Lead 10																600											567	533	500	467	433	400	367						350						300						250
	導程 Lead 20																1200											1133	1067	1000	933	867	800	733						700						600						500
	導程 Lead 32																1920											1813	1707	1600	1493	1387	1280						1173						960						800	

BM 馬達下折 Motor Bottom Side



• CAD圖面可至www.toyorobot.com下載 •
Please download the CAD file from TOYO's website : www.toyorobot.com

單位 Unit : mm

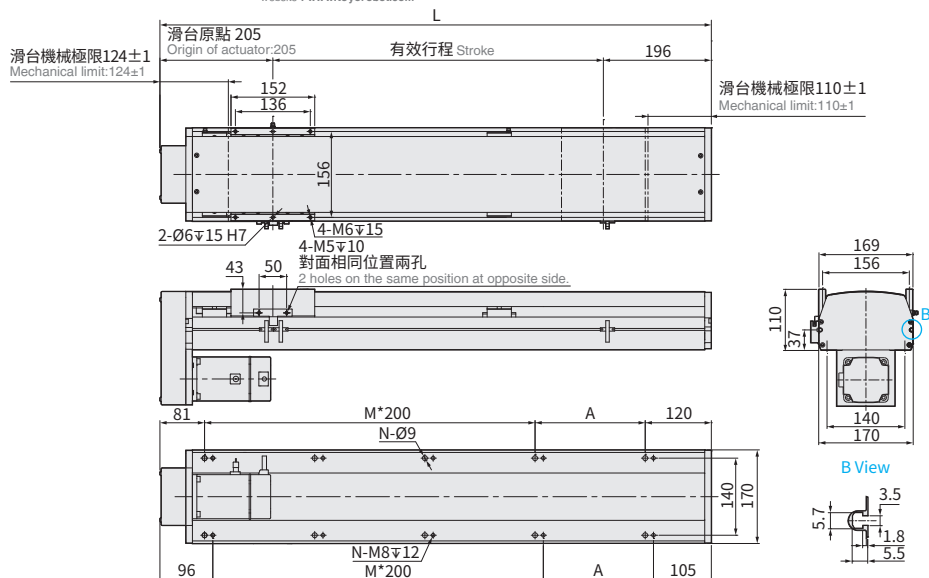

有效行程 Stroke	800	850	900	950	1000	1050	1100	1150	1200	1250	1300	1350	1400	1450	1500	1550	1600	1650	1700	1750	1800	1850	1900	1950	2000	2050	2100	2150	2200																							
極限行程 Limit Stroke (±1)	815	865	915	965	1015	1065	1115	1165	1215	1265	1315	1365	1415	1465	1515	1565	1615	1665	1715	1765	1815	1865	1915	1965	2015	2065	2115	2165	2215																							
L	1201	1251	1301	1351	1401	1451	1501	1551	1601	1651	1701	1751	1801	1851	1901	1951	2001	2051	2101	2151	2201	2251	2301	2351	2401	2451	2501	2551	2601																							
A	200	50	100	150	200	50	100	150	200	50	100	150	200	50	100	150	200	50	100	150	200	50	100	150	200	50	100	150	200																							
M	4	5	5	5	5	6	6	6	6	7	7	7	7	8	8	8	8	9	9	9	9	10	10	10	10	10	11	11	11																							
N	12	14	14	14	14	16	16	16	16	18	18	18	18	20	20	20	20	22	22	22	22	24	24	24	24	26	26	26	26																							
KG	30.61	31.29	31.97	32.65	33.33	34.01	34.69	35.37	36.05	36.73	37.41	38.09	38.77	39.45	40.13	40.81	41.49	42.17	42.85	43.53	44.21	44.89	45.57	46.25	46.93	47.61	48.29	48.97	49.65																							
線速度 Linear Speed mm/s	導程 Lead 5																300											283	267	250	233	217	200	183						175						150						125
	導程 Lead 10																600											567	533	500	467	433	400	367						350						300						250
	導程 Lead 20																1200											1133	1067	1000	933	867	800	733						700						600						500
	導程 Lead 32																1920											1813	1707	1600	1493	1387	1280						1173						960						800	

BL 馬達左折 Motor Left Side



● CAD圖面可至www.toyorobot.com下載 ●

Please download the CAD file from TOYO's website : www.toyorobot.com

單位 Unit : mm

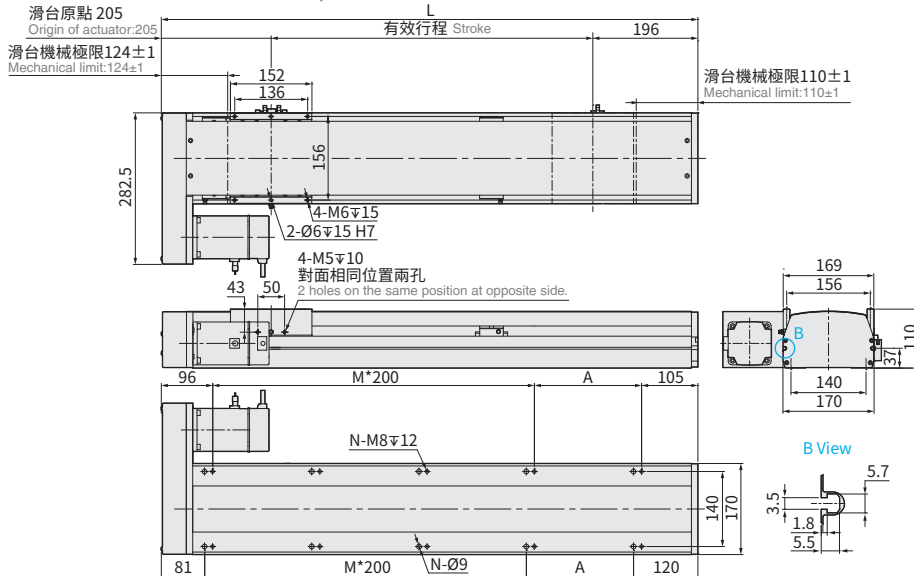

有效行程 Stroke	800	850	900	950	1000	1050	1100	1150	1200	1250	1300	1350	1400	1450	1500	1550	1600	1650	1700	1750	1800	1850	1900	1950	2000	2050	2100	2150	2200																																															
極限行程 Limit Stroke (±1)	815	865	915	965	1015	1065	1115	1165	1215	1265	1315	1365	1415	1465	1515	1565	1615	1665	1715	1765	1815	1865	1915	1965	2015	2065	2115	2165	2215																																															
L	1201	1251	1301	1351	1401	1451	1501	1551	1601	1651	1701	1751	1801	1851	1901	1951	2001	2051	2101	2151	2201	2251	2301	2351	2401	2451	2501	2551	2601																																															
A	200	50	100	150	200	50	100	150	200	50	100	150	200	50	100	150	200	50	100	150	200	50	100	150	200	50	100	150	200																																															
M	4	5	5	5	5	6	6	6	6	7	7	7	7	8	8	8	8	9	9	9	9	10	10	10	10	11	11	11	11																																															
N	12	14	14	14	14	16	16	16	16	18	18	18	18	20	20	20	20	22	22	22	22	24	24	24	24	26	26	26	26																																															
KG	30.61	31.29	31.97	32.65	33.33	34.01	34.69	35.37	36.05	36.73	37.41	38.09	38.77	39.45	40.13	40.81	41.49	42.17	42.85	43.53	44.21	44.89	45.57	46.25	46.93	47.61	48.29	48.97	49.65																																															
線速度 Linear Speed mm/s	導程 Lead 5																300											283	267	250	233	217	200	183											175											150											125									
	導程 Lead 10																600											567	533	500	467	433	400	367											350											300											250									
	導程 Lead 20																1200											1133	1067	1000	933	867	800	733											700											600											500									
	導程 Lead 32																1920											1813	1707	1600	1493	1387	1280											1173											1120											960										

BR 馬達右折 Motor Right Side



● CAD圖面可至www.toyorobot.com下載 ●

Please download the CAD file from TOYO's website : www.toyorobot.com

單位 Unit : mm

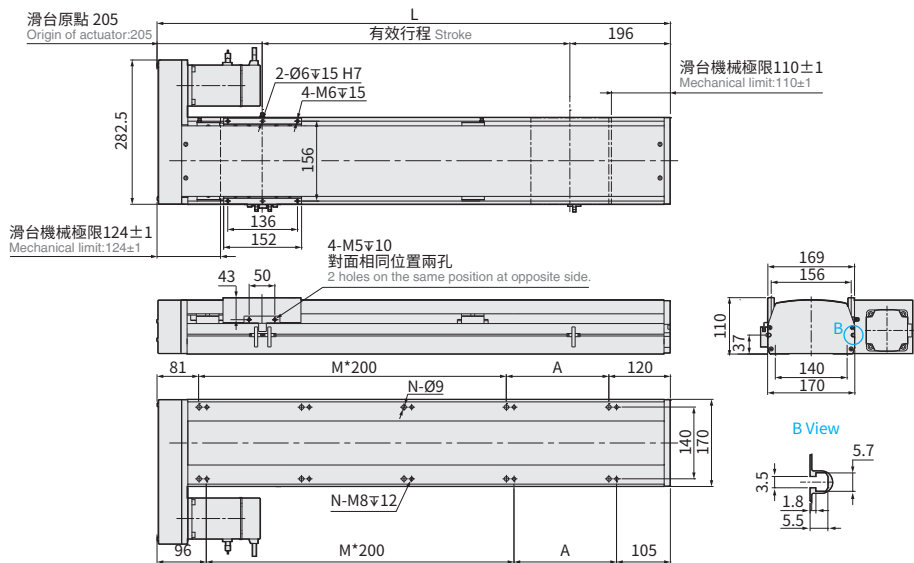

有效行程 Stroke	800	850	900	950	1000	1050	1100	1150	1200	1250	1300	1350	1400	1450	1500	1550	1600	1650	1700	1750	1800	1850	1900	1950	2000	2050	2100	2150	2200																																															
極限行程 Limit Stroke (±1)	815	865	915	965	1015	1065	1115	1165	1215	1265	1315	1365	1415	1465	1515	1565	1615	1665	1715	1765	1815	1865	1915	1965	2015	2065	2115	2165	2215																																															
L	1201	1251	1301	1351	1401	1451	1501	1551	1601	1651	1701	1751	1801	1851	1901	1951	2001	2051	2101	2151	2201	2251	2301	2351	2401	2451	2501	2551	2601																																															
A	200	50	100	150	200	50	100	150	200	50	100	150	200	50	100	150	200	50	100	150	200	50	100	150	200	50	100	150	200																																															
M	4	5	5	5	5	6	6	6	6	7	7	7	7	8	8	8	8	9	9	9	9	10	10	10	10	10	11	11	11	11																																														
N	12	14	14	14	14	16	16	16	16	18	18	18	18	20	20	20	20	22	22	22	22	24	24	24	24	26	26	26	26																																															
KG	30.61	31.29	31.97	32.65	33.33	34.01	34.69	35.37	36.05	36.73	37.41	38.09	38.77	39.45	40.13	40.81	41.49	42.17	42.85	43.53	44.21	44.89	45.57	46.25	46.93	47.61	48.29	48.97	49.65																																															
線速度 Linear Speed mm/s	導程 Lead 5																300											283	267	250	233	217	200	183											175											150											125									
	導程 Lead 10																600											567	533	500	467	433	400	367											350											300											250									
	導程 Lead 20																1200											1133	1067	1000	933	867	800	733											700											600											500									
	導程 Lead 32																1920											1813	1707	1600	1493	1387	1280											1173											1120											960										

ETH Series

ETH13

ETH14

ETH17

ETH22

ETH17M

ETH22M

ETH22M 單軸 /1-axis

▶ 螺桿驅動
Ball Screw Drive

精度
±0.005 mm

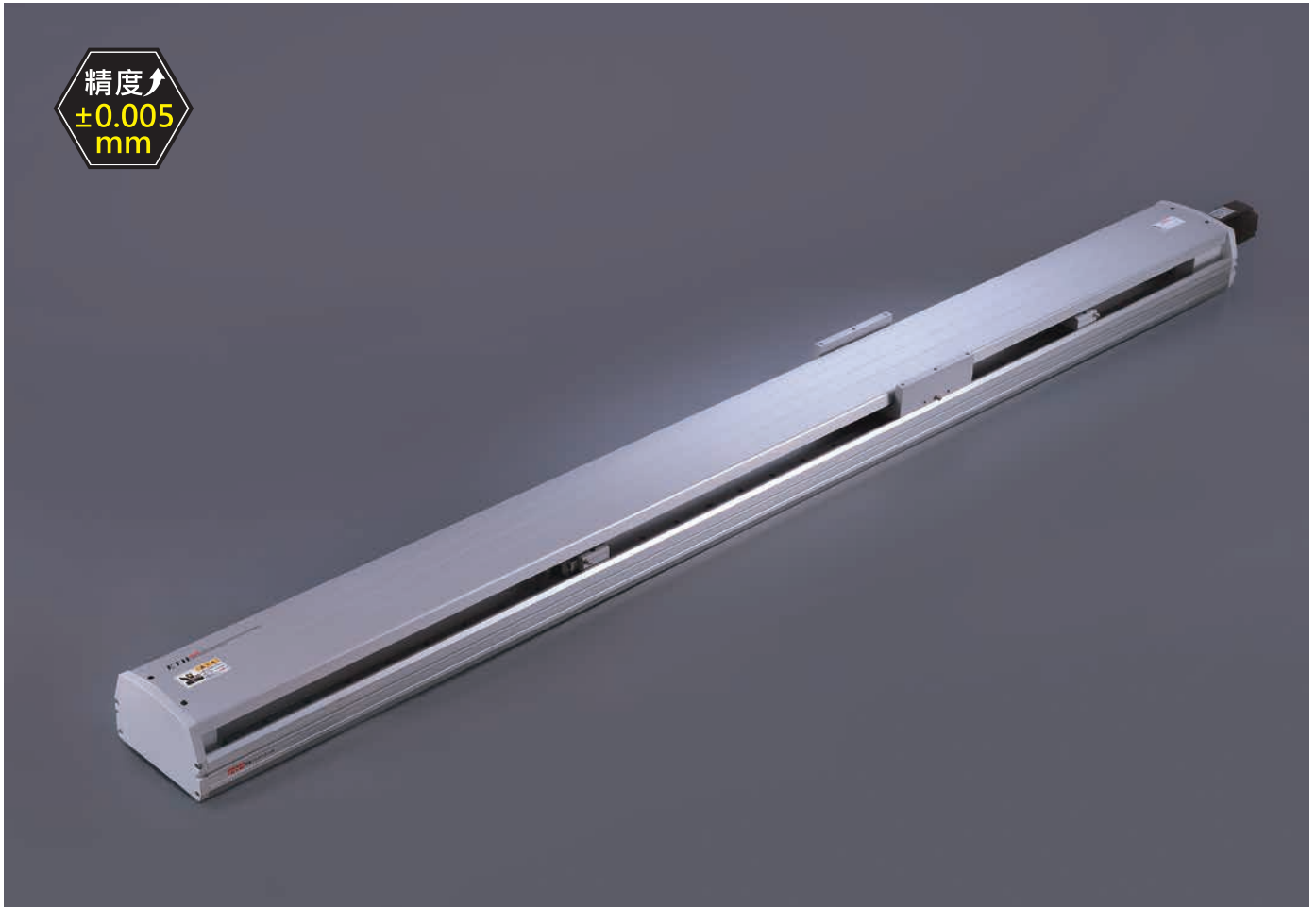

- 最大行程 Maximum Stroke: 2400mm
- 最高速度 Maximum Speed: 2400mm/s
- 馬達容量 Motor Output: 750W
- 滾珠螺桿 Ball Screw: ø20mm
- 直線滑軌 Linear Guide: 20X15-2 支

型號表示方式 Ordering Method

ETH22M - L10 - 850 - M - M75B - C4N5 - 參照右頁
Refer to the right page. - 0001

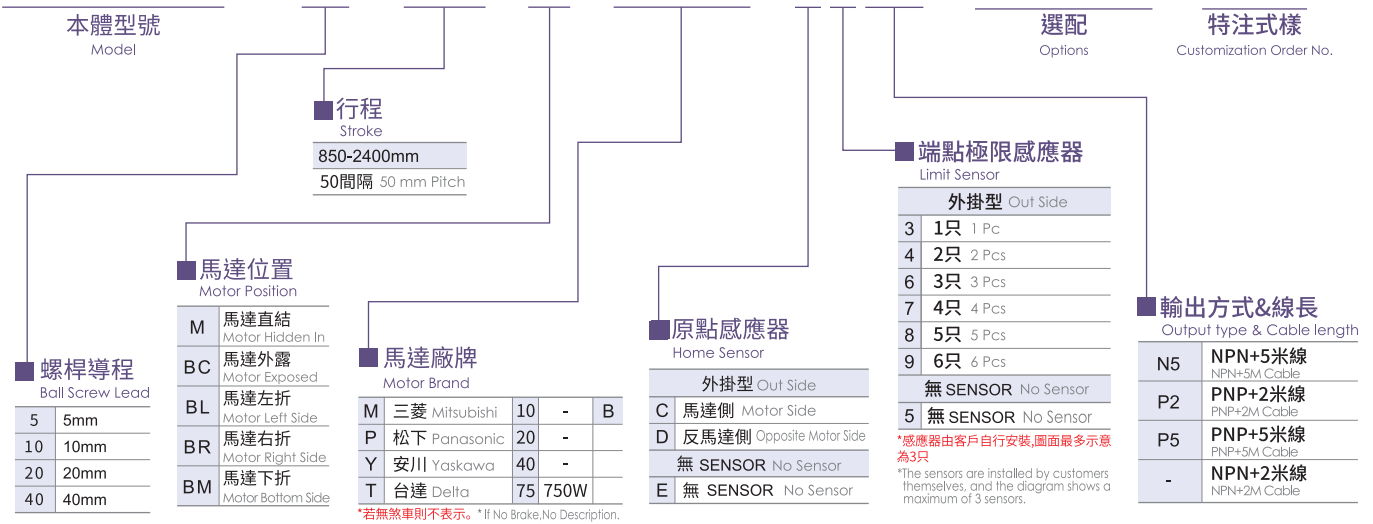

基本仕様 Specification

性能	位置重複精度 Repeatability	mm	±0.005				
	螺桿導程 Lead	mm	5	10	20	40	
	最高轉速 Maximum Rotating speed	rpm	3600	3600	3600	3600	
	最高速度 Maximum linear speed ^{**1}	mm/s	300	600	1200	2400	
	最大可搬重量 Maximum Payload	水平使用 Horizontal	kg	130	130	85	43
		垂直使用 Vertical	kg	50	40	25	12
	定格推力 Rated Thrust	N	2563	1281	640	320	
部品	標準行程 Stroke (increments)	mm	850-2400mm/50 間隔 (50 increments)				
	AC 伺服馬達容量 AC Servo Motor Output	W	750				
	滾珠螺桿外徑 Ball Screw Ø	mm	C7Ø20				
	高剛性直線滑軌 High Rigidity Linear Guide	mm	W20XH15				
	連軸器 Coupling	mm	12X19				
	原點感應器 Home Sensor	外掛 Outside	T62N2 (NPN+2 米線) (NPN+2M Cable)				

^{**1}長行程時，會產生螺桿偏擺，需將速度調降 (線速度請參閱尺寸圖下方表格)

During in a long stroke, it causes ballscrew deflection, the speed must reduce. (Please refer to the linear velocity from the data sheet below the dimension graph.)

容許負載力距表 Allowable Overhang

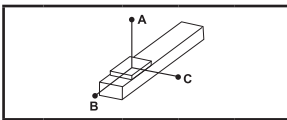

(單位 Unit : mm)

水平安裝 Horizontal Installation		A	B	C
導程 5 Lead	80kg	3311	408	389
	100kg	2534	312	298
	130kg	2113	223	213
導程 10 Lead	70kg	2170	413	374
	90kg	1634	305	277
	130kg	1054	189	172
導程 20 Lead	40kg	1469	568	460
	60kg	939	354	288
	85kg	627	229	187
導程 40 Lead	20kg	984	766	496
	25kg	775	599	388
	43kg	425	318	208

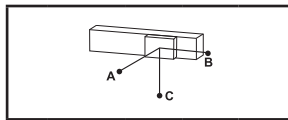

(單位 Unit : mm)

壁掛安裝 Wall Installation		A	B	C
導程 5 Lead	80kg	389	408	3311
	100kg	298	312	2534
	130kg	213	223	2113
導程 10 Lead	70kg	374	413	2170
	90kg	277	305	1634
	130kg	172	189	1054
導程 20 Lead	40kg	460	568	1469
	60kg	288	354	939
	85kg	187	229	627
導程 40 Lead	20kg	496	766	984
	25kg	388	599	775
	43kg	208	318	425

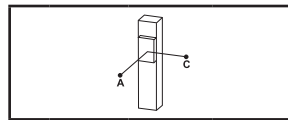

(單位 Unit : mm)

垂直安裝 Vertical Installation		A	C
導程 5 Lead	30kg	1272	1272
	40kg	954	954
	50kg	763	763
導程 10 Lead	20kg	1655	1655
	30kg	1103	1103
	40kg	827	827
導程 20 Lead	15kg	1555	1555
	20kg	1166	1166
	25kg	933	933
導程 40 Lead	7kg	1824	1824
	9kg	1419	1419
	12kg	1064	1064

靜額定扭矩 Static Loading Moment

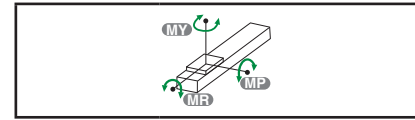

(單位 Unit : N.m)

MY	1254
MP	1254
MR	1254

*力矩表所表示的數據，代表荷重的重心位置於單一方容許懸出的長度。
 The data represented by the moment table is the center of gravity of the load. The length of the overhang is allowed in a single direction.
 *符合型錄規範的正常使用下，保證壽命為 10000 公里。
 Operation life is 10,000km when the product is using under the specified conditions.
 *倒吊使用無法套用標準規範，如有需求請洽詢我司業務。
 Data information is not for ceiling-mount inverse use. Contact us for the details if you want to apply ceiling-mount inverse usage.
 *壽命及力矩是以馬達加減速設定 0.2 秒計算。
 The life and torque are calculated by setting the motor acceleration and deceleration for 0.2 seconds.

選配 Options

NL		P		EB		MM		CMK		
外拉式注油嘴位置 External oil injection nozzle position		標準 PIN 孔 Standard PIN hole		外觀黑色處理 Outer layer is treated with black oxide		指定馬達出線方向 Selectable Cable Leading Direction		馬達傳動配件追加鍵槽 Additional keyway for motor drive parts		
代號 Code	說明 Instructions	需參照 Refer to	代號 Code	說明 Instructions	需參照 Refer to	代號 Code	說明 Instructions	代號 Code	說明 Instructions	需參照 Refer to
NL	滑座右側 On The Right of The Slider	P.675 ~ P.676	P	標準 PIN 孔 Standard PIN hole	P.677	EB	黑色 Black	MW	朝上 Upper side	P.679 ~ P.680
NR	滑座右側 On The Right of The Slider		EB	本體 Main Body	P.678	MM	朝下 Bottom side	CMK	單邊 (限馬達側) Single (Limited to the motor side)	
NRL	滑座雙邊注油 Slide both sides for oil injection		EB	不銹鋼板 Stainless steel plate		SKY	雙邊 Double	CMK	雙邊 Double	
			EB	螺絲 Screw		MR	朝右 Right side	SKN	雙邊 Double	
									BL/BR/BM	P.681 ~ P.682

ETH22M 單軸 /1-axis



M 馬達直結 Motor Hidden In



● CAD圖面可至www.toyorobot.com下載 ●
Please download the CAD file from TOYO's website : www.toyorobot.com

單位 Unit : mm

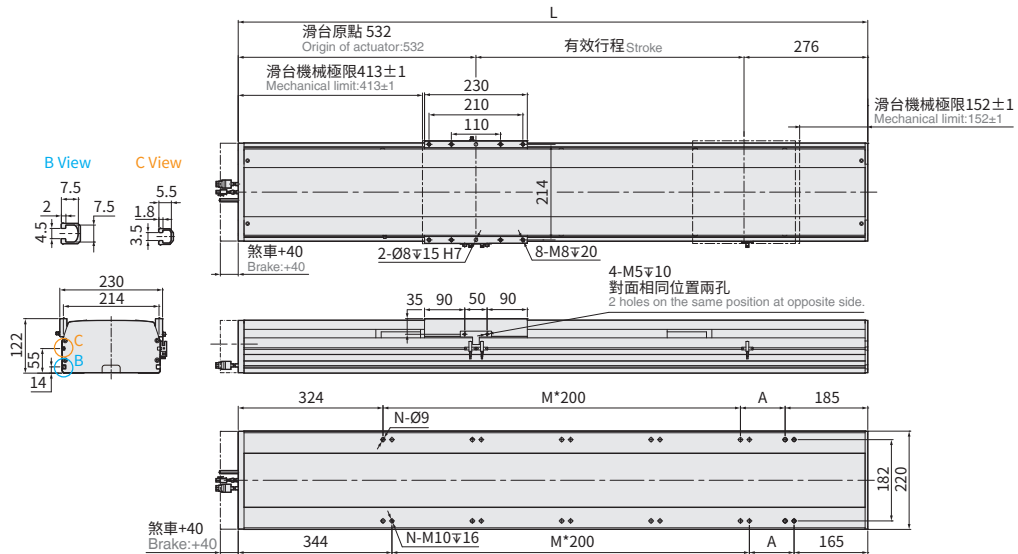

有效行程 Stroke	850	900	950	1000	1050	1100	1150	1200	1250	1300	1350	1400	1450	1500	1550	1600	1650	1700	1750	1800	1850	1900	1950	2000	2050	2100	2150	2200	2250	2300	2350	2400			
極限行程 Limit Stroke (±1)	864	914	964	1014	1064	1114	1164	1214	1264	1314	1364	1414	1464	1514	1564	1614	1664	1714	1764	1814	1864	1914	1964	2014	2064	2114	2164	2214	2264	2314	2364	2414			
L	1659	1709	1759	1809	1859	1909	1959	2009	2059	2109	2159	2209	2259	2309	2359	2409	2459	2509	2559	2609	2659	2709	2759	2809	2859	2909	2959	3009	3059	3109	3159	3209			
A	150	200	50	100	150	200	50	100	150	200	50	100	150	200	50	100	150	200	50	100	150	200	50	100	150	200	50	100	150	200	50	100			
M	5	5	6	6	6	6	7	7	7	7	8	8	8	8	9	9	9	9	10	10	10	10	11	11	11	11	12	12	12	12	13	13			
N	14	14	16	16	16	16	18	18	18	18	20	20	20	20	22	22	22	22	24	24	24	24	26	26	26	26	28	28	28	28	30	30			
KG	56.61	57.97	59.33	60.69	62.05	63.41	64.77	66.13	67.49	68.85	70.21	71.57	72.93	74.29	75.65	77.01	78.37	79.73	81.09	82.45	83.81	85.17	86.53	87.89	89.25	90.61	91.97	93.33	94.69	96.05	97.41	98.77			
線速度 Linear Speed mm/s	導程 Lead 5	300															283	267	250	233	225	217	208	200										175	150
	導程 Lead 10	600															567	533	500	467	450	433	417	400										350	300
	導程 Lead 20	1200															1133	1067	1000	933	900	867	833	800										700	600
	導程 Lead 40	2400															2267	2133	2000	1867	1800	1733	1667	1600										1400	1200

BC 馬達外露 Motor Exposed



● CAD圖面可至www.toyorobot.com下載 ●
Please download the CAD file from TOYO's website : www.toyorobot.com

單位 Unit : mm

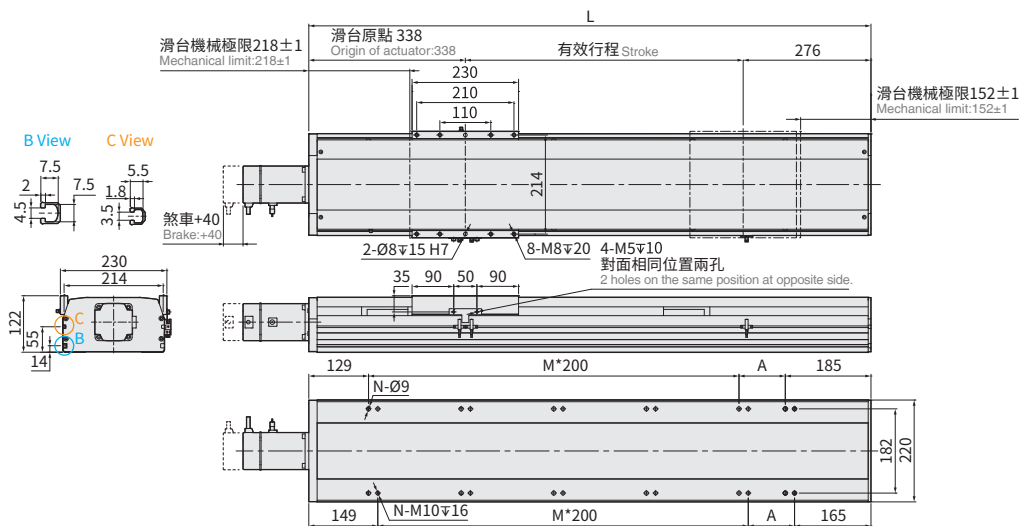

有效行程 Stroke	850	900	950	1000	1050	1100	1150	1200	1250	1300	1350	1400	1450	1500	1550	1600	1650	1700	1750	1800	1850	1900	1950	2000	2050	2100	2150	2200	2250	2300	2350	2400			
極限行程 Limit Stroke (±1)	864	914	964	1014	1064	1114	1164	1214	1264	1314	1364	1414	1464	1514	1564	1614	1664	1714	1764	1814	1864	1914	1964	2014	2064	2114	2164	2214	2264	2314	2364	2414			
L	1464	1514	1564	1614	1664	1714	1764	1814	1864	1914	1964	2014	2064	2114	2164	2214	2264	2314	2364	2414	2464	2514	2564	2614	2664	2714	2764	2814	2864	2914	2964	3014			
A	150	200	50	100	150	200	50	100	150	200	50	100	150	200	50	100	150	200	50	100	150	200	50	100	150	200	50	100	150	200	50	100			
M	5	5	6	6	6	6	7	7	7	7	8	8	8	8	9	9	9	9	10	10	10	10	11	11	11	11	12	12	12	12	13	13			
N	14	14	16	16	16	16	18	18	18	18	20	20	20	20	22	22	22	22	24	24	24	24	26	26	26	26	28	28	28	28	30	30			
KG	53.91	55.27	56.63	57.99	59.35	60.71	62.07	63.43	64.79	66.15	67.51	68.87	70.23	71.59	72.95	74.31	75.67	77.03	78.39	79.75	81.11	82.47	83.83	85.19	86.55	87.91	89.27	90.63	91.99	93.35	94.71	96.07			
線速度 Linear Speed mm/s	導程 Lead 5	300															283	267	250	233	225	217	208	200										175	150
	導程 Lead 10	600															567	533	500	467	450	433	417	400										350	300
	導程 Lead 20	1200															1133	1067	1000	933	900	867	833	800										700	600
	導程 Lead 40	2400															2267	2133	2000	1867	1800	1733	1667	1600										1400	1200

免費服務專線：大陸 400-875-0009 台灣 0800-800-893
 Toll-Free Number China Taiwan

應用例
Application

一般 / 螺桿仕様
ETH

一般 / 皮帶仕様
ETB / M

無塵 / 螺桿仕様
GCH / ECH

無塵 / 皮帶仕様
ECB

直交連結
XGT / XTH / XTB

參考資料
Reference

BL 馬達左折 Motor Left Side



CAD圖面可至www.toyorobot.com下載

Please download the CAD file from TOYO's website : www.toyorobot.com

單位 Unit : mm

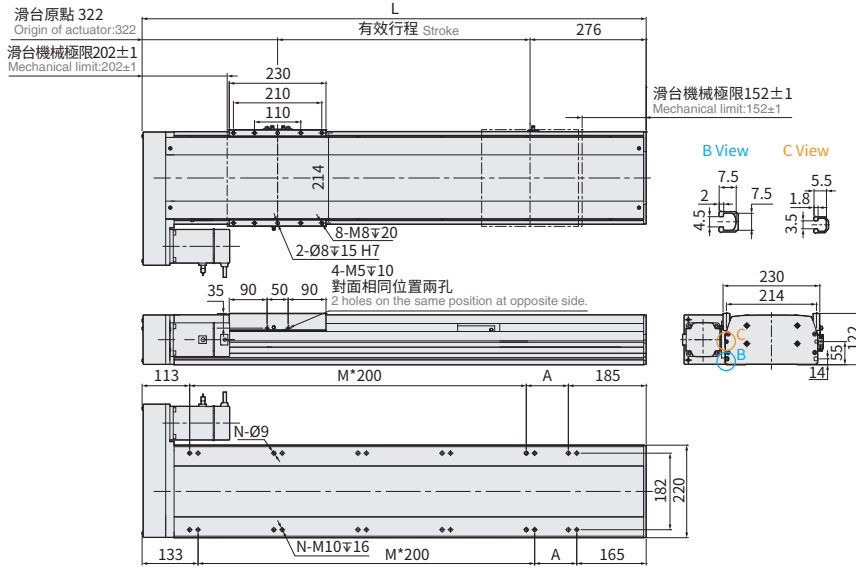

有效行程 Stroke	850	900	950	1000	1050	1100	1150	1200	1250	1300	1350	1400	1450	1500	1550	1600	1650	1700	1750	1800	1850	1900	1950	2000	2050	2100	2150	2200	2250	2300	2350	2400				
極限行程 Limit Stroke (±1)	864	914	964	1014	1064	1114	1164	1214	1264	1314	1364	1414	1464	1514	1564	1614	1664	1714	1764	1814	1864	1914	1964	2014	2064	2114	2164	2214	2264	2314	2364	2414				
L	1448	1498	1548	1598	1648	1698	1748	1798	1848	1898	1948	1998	2048	2098	2148	2198	2248	2298	2348	2398	2448	2498	2548	2598	2648	2698	2748	2798	2848	2898	2948	2998				
A	150	200	50	100	150	200	50	100	150	200	50	100	150	200	50	100	150	200	50	100	150	200	50	100	150	200	50	100	150	200	50	100				
M	5	5	6	6	6	6	7	7	7	7	8	8	8	8	9	9	9	9	10	10	10	10	11	11	11	11	12	12	12	12	13	13				
N	14	14	16	16	16	16	18	18	18	18	20	20	20	20	22	22	22	22	24	24	24	24	26	26	26	26	28	28	28	28	30	30				
KG	55.11	56.47	57.83	59.19	60.55	61.91	63.27	64.63	65.99	67.35	68.71	70.07	71.43	72.79	74.15	75.51	76.87	78.23	79.59	80.95	82.31	83.67	85.03	86.39	87.75	89.11	90.47	91.83	93.19	94.55	95.91	97.27				
線速度 Linear Speed mm/s	導程 Lead 5	300																283	267	250	233	225	217	208	200										175	150
	導程 Lead 10	600																567	533	500	467	450	433	417	400										350	300
	導程 Lead 20	1200																1133	1067	1000	933	900	867	833	800										700	600
	導程 Lead 40	2400																2267	2133	2000	1867	1800	1733	1667	1600										1400	1200

BR 馬達右折 Motor Right Side



CAD圖面可至www.toyorobot.com下載

Please download the CAD file from TOYO's website : www.toyorobot.com

單位 Unit : mm

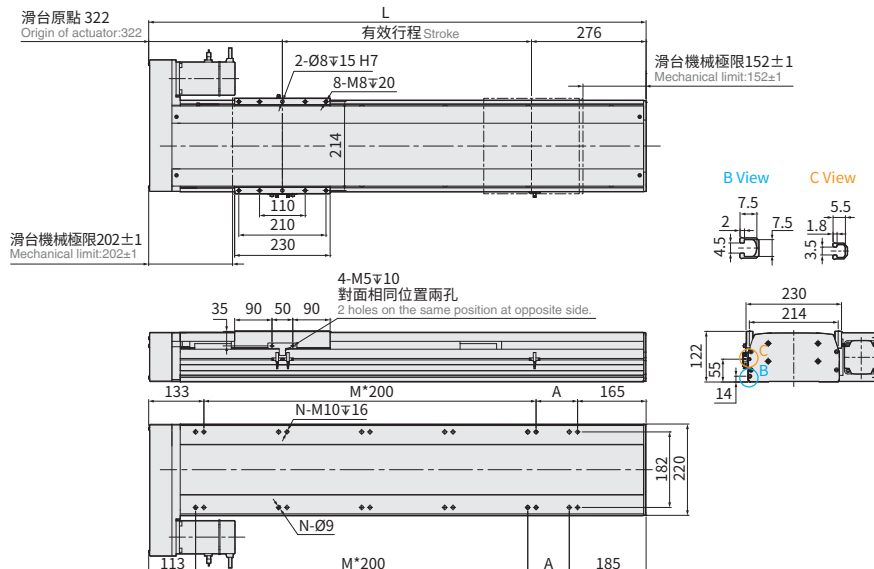

有效行程 Stroke	850	900	950	1000	1050	1100	1150	1200	1250	1300	1350	1400	1450	1500	1550	1600	1650	1700	1750	1800	1850	1900	1950	2000	2050	2100	2150	2200	2250	2300	2350	2400				
極限行程 Limit Stroke (±1)	864	914	964	1014	1064	1114	1164	1214	1264	1314	1364	1414	1464	1514	1564	1614	1664	1714	1764	1814	1864	1914	1964	2014	2064	2114	2164	2214	2264	2314	2364	2414				
L	1448	1498	1548	1598	1648	1698	1748	1798	1848	1898	1948	1998	2048	2098	2148	2198	2248	2298	2348	2398	2448	2498	2548	2598	2648	2698	2748	2798	2848	2898	2948	2998				
A	150	200	50	100	150	200	50	100	150	200	50	100	150	200	50	100	150	200	50	100	150	200	50	100	150	200	50	100	150	200	50	100				
M	5	5	6	6	6	6	7	7	7	7	8	8	8	8	9	9	9	9	10	10	10	10	11	11	11	11	12	12	12	12	13	13				
N	14	14	16	16	16	16	18	18	18	18	20	20	20	20	22	22	22	22	24	24	24	24	26	26	26	26	28	28	28	28	30	30				
KG	55.11	56.47	57.83	59.19	60.55	61.91	63.27	64.63	65.99	67.35	68.71	70.07	71.43	72.79	74.15	75.51	76.87	78.23	79.59	80.95	82.31	83.67	85.03	86.39	87.75	89.11	90.47	91.83	93.19	94.55	95.91	97.27				
線速度 Linear Speed mm/s	導程 Lead 5	300																283	267	250	233	225	217	208	200										175	150
	導程 Lead 10	600																567	533	500	467	450	433	417	400										350	300
	導程 Lead 20	1200																1133	1067	1000	933	900	867	833	800										700	600
	導程 Lead 40	2400																2267	2133	2000	1867	1800	1733	1667	1600										1400	1200

ETH Series

ETH13

ETH14

ETH17

ETH22

ETH17M

ETH22M

ETH22M 單軸 /1-axis

BM 馬達下折 Motor Bottom Side



CAD圖面可至www.toyorobot.com下載
Please download the CAD file from TOYO's website : www.toyorobot.com

單位 Unit : mm

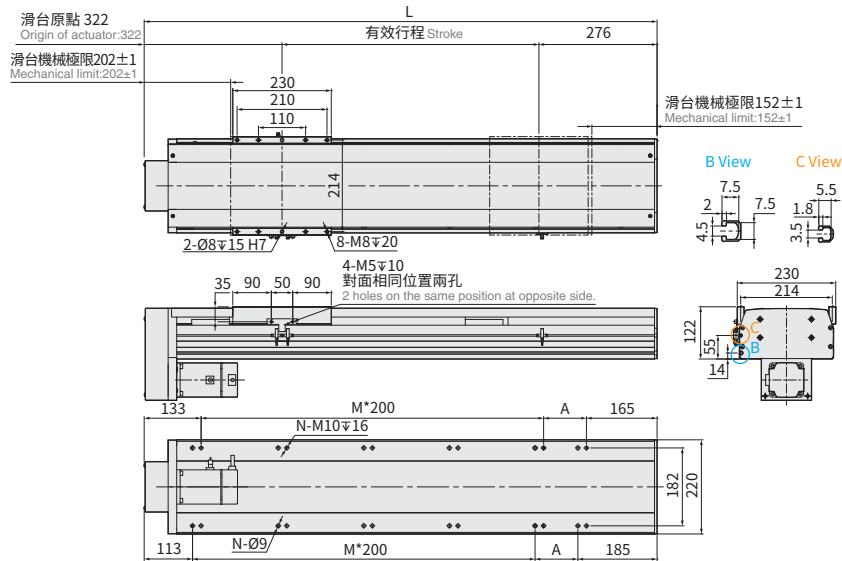

有效行程 Stroke	850	900	950	1000	1050	1100	1150	1200	1250	1300	1350	1400	1450	1500	1550	1600	1650	1700	1750	1800	1850	1900	1950	2000	2050	2100	2150	2000	2250	2300	2350	2400									
極限行程 Limit Stroke (± 1)	864	914	964	1014	1064	1114	1164	1214	1264	1314	1364	1414	1464	1514	1564	1614	1664	1714	1764	1814	1864	1914	1964	2014	2064	2114	2164	2214	2264	2314	2364	2414									
L	1448	1498	1548	1598	1648	1698	1748	1798	1848	1898	1948	1998	2048	2098	2148	2198	2248	2298	2348	2398	2448	2498	2548	2598	2648	2698	2748	2798	2848	2898	2948	2998									
A	150	200	50	100	150	200	50	100	150	200	50	100	150	200	50	100	150	200	50	100	150	200	50	100	150	200	50	100	150	200	50	100									
M	5	5	6	6	6	6	7	7	7	7	8	8	8	8	9	9	9	9	10	10	10	10	10	11	11	11	11	12	12	12	12	13	13								
N	14	14	16	16	16	16	18	18	18	18	20	20	20	20	22	22	22	22	24	24	24	24	24	26	26	26	26	28	28	28	28	30	30								
KG	55.11	56.47	57.83	59.19	60.55	61.91	63.27	64.63	65.99	67.35	68.71	70.07	71.43	72.79	74.15	75.51	76.87	78.23	79.59	80.95	82.31	83.67	85.03	86.39	87.75	89.11	90.47	91.83	93.19	94.55	95.91	97.27									
線速度 Linear Speed mm/s	導程 Lead 5																283	267	250	233	225	217	208						200						175						150
	導程 Lead 10																567	533	500	467	450	433	417						400						350						300
	導程 Lead 20																1133	1067	1000	933	900	867	833						800						700						600
	導程 Lead 40																2267	2133	2000	1867	1800	1733	1667						1600						1400						1200

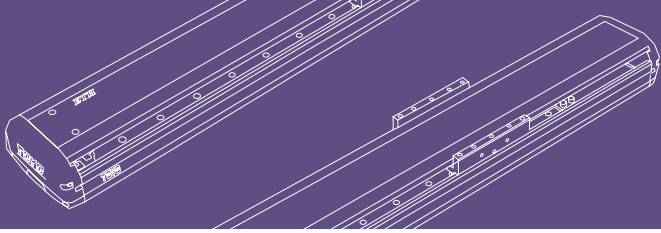

免費服務專線：大陸 400-875-0009 台灣 0800-800-893
Toll-Free Number China Taiwan

應用例
Application

一般 / 螺桿仕様
ETH

一般 / 皮帶仕様
ETB / M

無塵 / 螺桿仕様
GCH / ECH

無塵 / 皮帶仕様
ECB

直交連結
XYGT / XTH / XYTB

參考資料
Reference

Memo

ETH Series

ETH13

ETH14

ETH17

ETH22

ETH17M

ETH22M