

TOYO AGVS

Automated carts for lean transport.

Carts and Kits

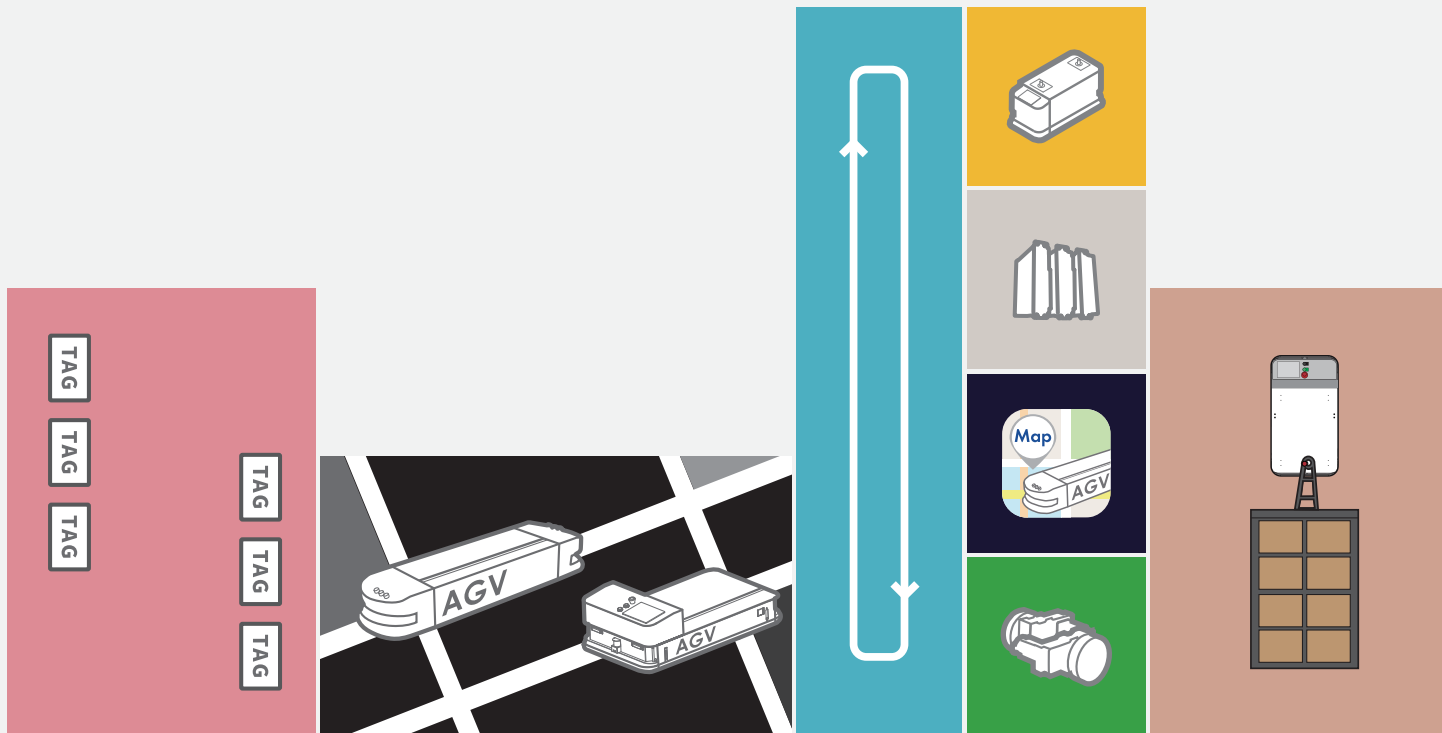

Toyo AGV Kit system – more than just a component. 東佑達AGV套件系統 – 絕對不只是個零件

► TOYO AGV KIT – System idea

東佑達的AGV套件 – 完整系統概念

► Perfectly coordinated system consisting of wheel ,mounting connection 、 guide sensor 、 controller and electronic

套件包含有車輪、安裝連接件、導引感應器、控制器及完整的電子系統



Advantages of TOYO AGV KIT system

東佑達AGV套件系統的優點

▶ 整合減速機與同步伺服馬達之緊湊型系統
Compact system consisting of planetary gearbox and synchronous servomotor.

▶ 驅動器軸承負載的最佳化設計
Optimized load of the bearings of the actuator.

▶ 輔助解決方案、如用於檢查速度的編碼器
Auxiliary solutions like encoder for checking the speed.

▶ 24V或48V兩種系統
With 24V or 48V system.

▶ 提供關於驅動系統的工程技术 和諮詢服務
Engineering and consulting regarding the drive system.

▶ 整合兩軸伺服馬達的控制器
Servo driver with dual Axis integration Controller.

▶ 容易搬運車上的PLC整合
Easy integration in the PLC of the vehicle.

▶ 容易組裝在搬運車上
Easy assembly in the vehicle.



Application Examples

應用範例

► Multi-purpose / more-mode application
多種用途 / 多種應用模式

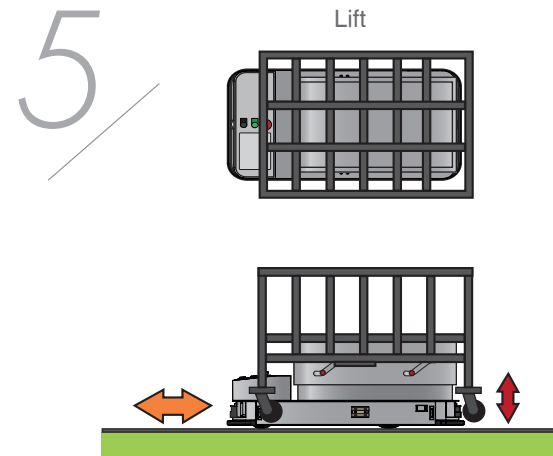
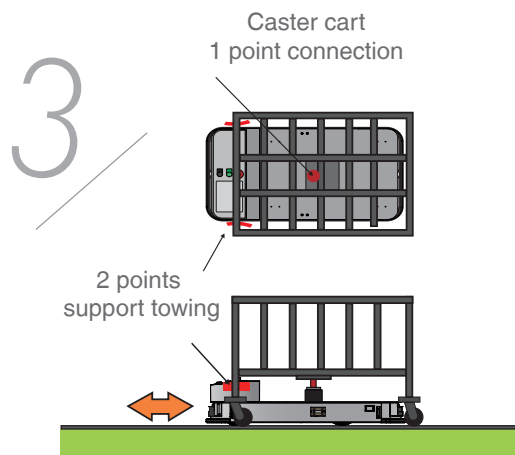
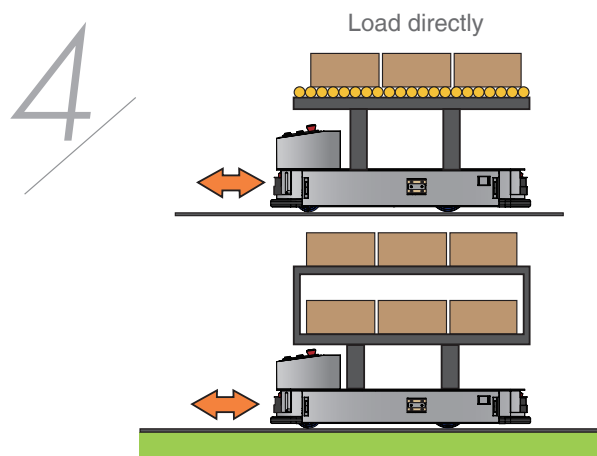
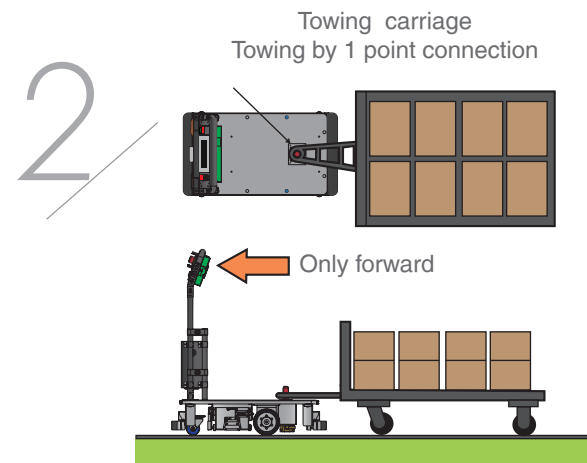
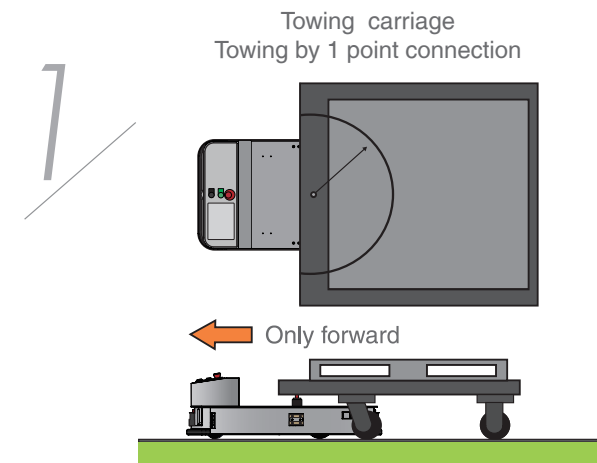

Software – easy and fast

軟體－簡單又快速

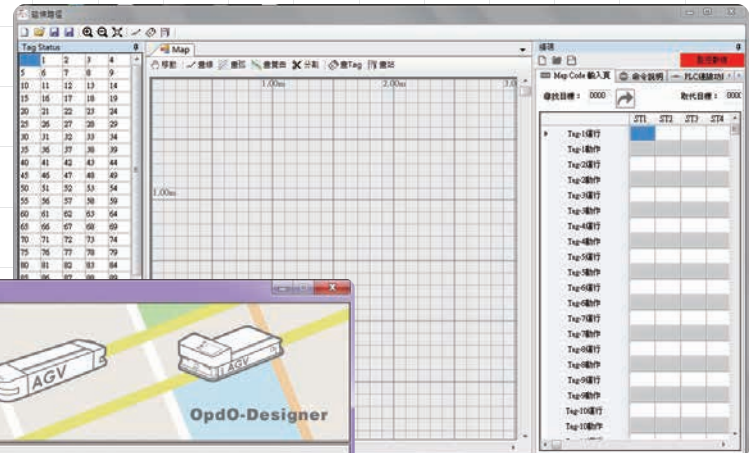
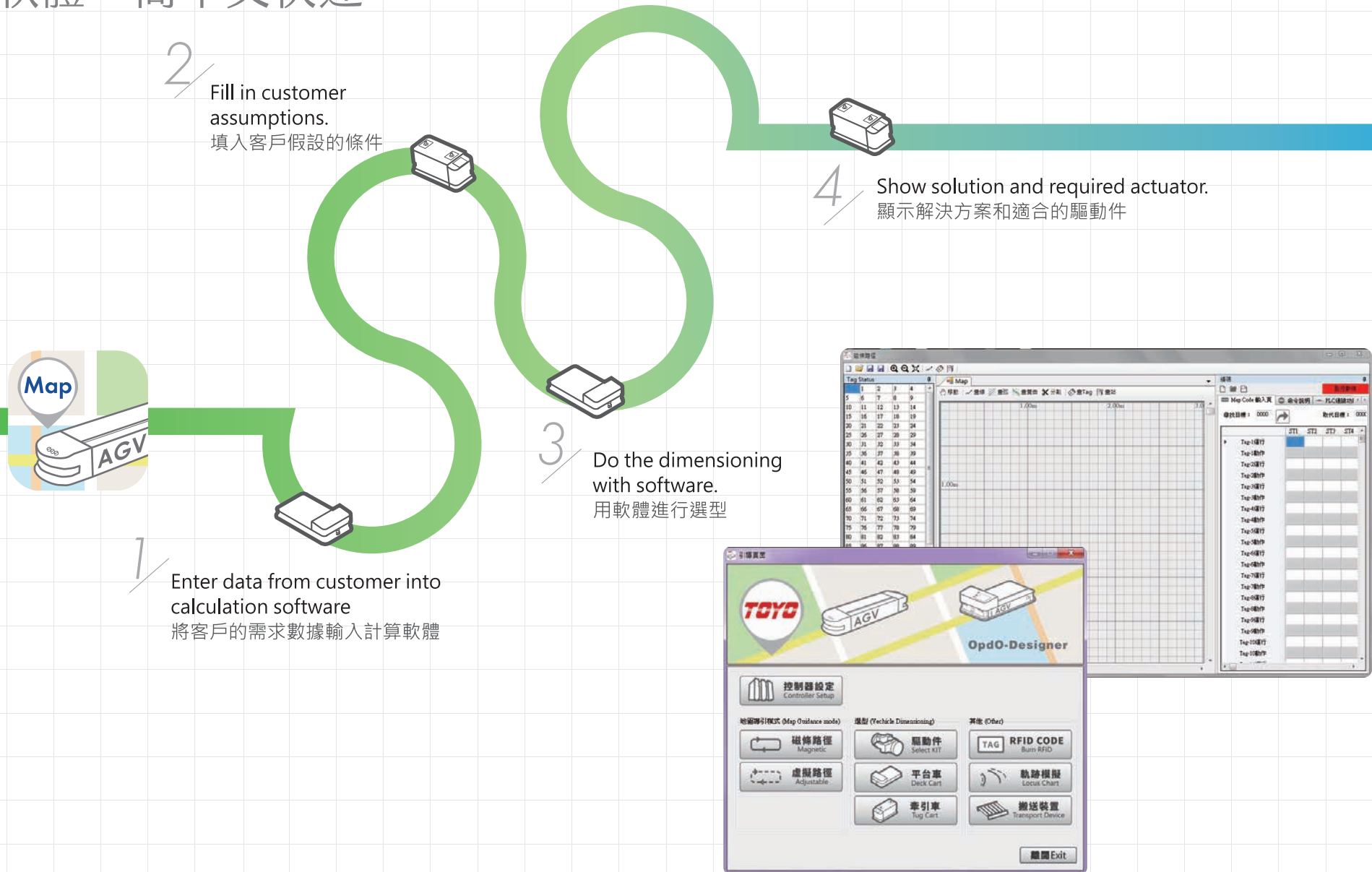

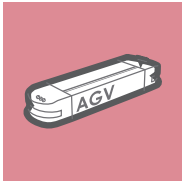

CARRY-E64 | Series



Forward & backward
前後進走行



16 Carry Cart



Speed
速度

10m/min
~
30m/min



Towing Force
牽引重量

1000KG
Max



Battery
Voltage
電池電壓

24V/80AH
Lead-acid batteries
鉛酸電池



Guide Mode
導引方式

Magnetic
type
磁性膠帶



Dimension
尺寸

1480mm
x
600mm
x
400mm



AGV Mass
車身重量

370KG
Max



Charging
Method
充電方式

Auto Charging
自動充電



AGV Kit
套件規格

MK5B-15B

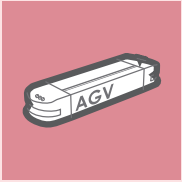

CARRY-F58 | Series



Forward & backward
前後進走行



17 Carry Cart



Speed
速度

10m/min
~
60m/min



Dimension
尺寸

1600mm
x
600mm
x
1130mm



Payload
負載重量

100KG
Max



AGV Mass
車身重量

380KG
Max



Battery
Voltage
電池電壓

24V/50AH
LiNi0.3Co0.3Mn0.3O2
鋰電池



Charging
Method
充電方式

Auto Charging
自動充電



Guide Mode
導引方式

Magnetic
type
磁性膠帶



AGV Kit
套件規格

MK2B-15A

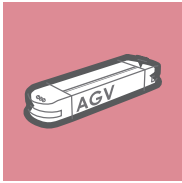

CARRY-K65 | Series



Forward
前進走行



18 Carry Cart



Speed
速度

10m/min
~
30m/min



Payload
負載重量

300KG
Max



Battery
Voltage
電池電壓

24V/50AH
Lead-acid batteries
鉛酸電池



Guide Mode
導引方式

Magnetic
type
磁性膠帶



Dimension
尺寸

1980mm
x
640mm
x
475mm



AGV Mass
車身重量

380KG
Max



Charging
Method
充電方式

Auto Charging
自動充電



AGV Kit
套件規格

MK5F-15B

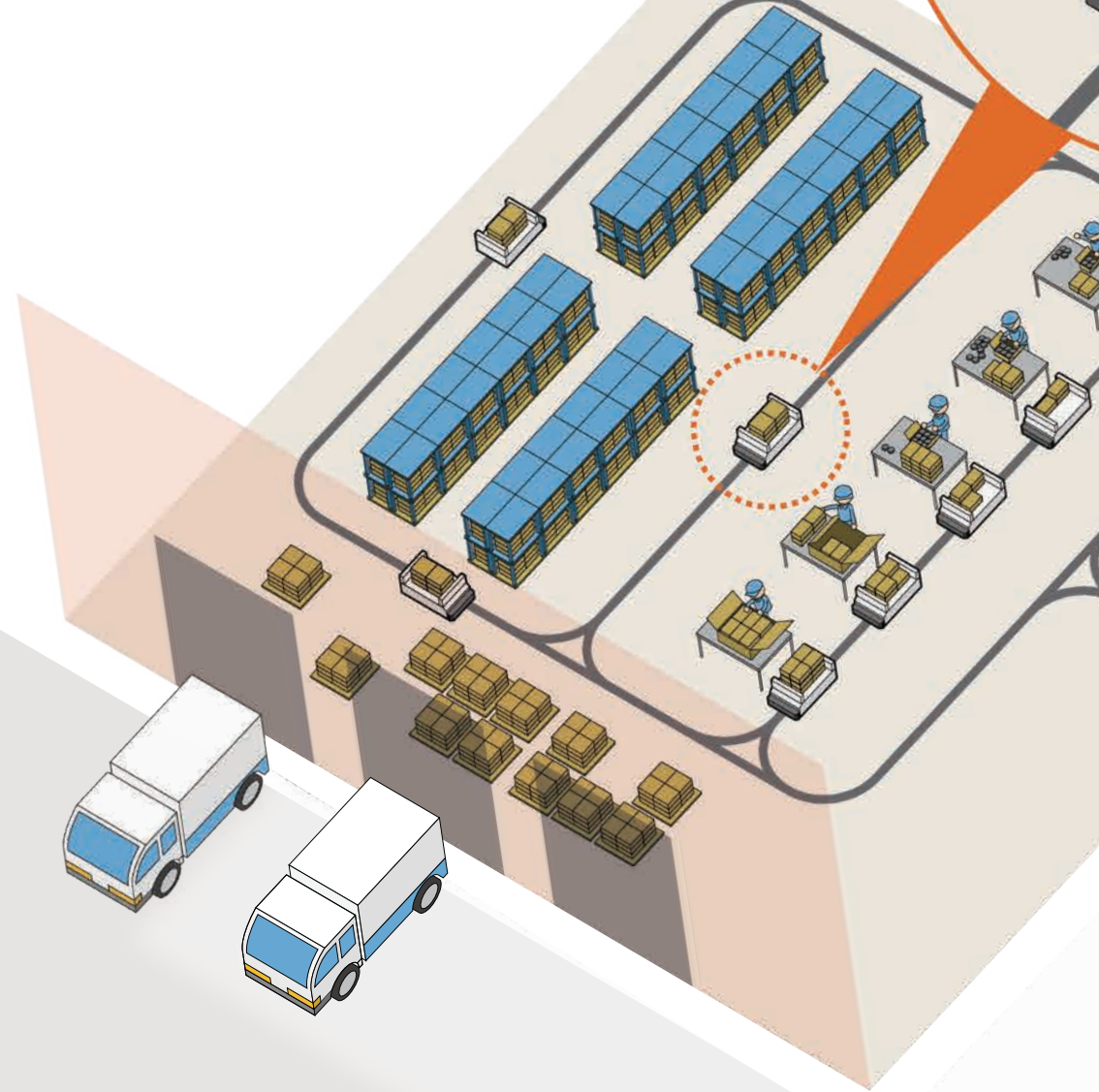

24 Taiwan: 0800-800-893

24 China: 400-875-0009

※本型錄內容會有因產品改良而有變更的可能性，恕不另行通知。

※本型錄產品已投保1500萬台幣產品責任險。

Copyright © TOYO AUTOMATION CO.,LTD 版權所有，翻印必究！

東佑達自動化科技股份有限公司

台南市安南區新吉三路55號
T:+886-6-2021347 F:+886-6-2025974

東佑達機器人(蘇州)有限公司

江蘇省昆山市張浦鎮振新東路586號(浩盛工業園C12-2)
T:+86-512-86890880 F:+86-512-86890881

TOYO Robotics 株式会社

Kanagawa Prefecture Fujisawa City Katase 3-8-20-204 JAPAN.
E-mail: yoyusa@toyorobot.com

東佑達自動化科技(深圳)有限公司

深圳市寶安區龍華大浪華榮路明君商務中心1208室
T:+86-755-81713415 F:+86-755-81713435

TOYO Robot (Thailand) Co., Ltd.

118/27 Moo 18 Klong Nueng Klong Luang Pathumthani 12120 THAILAND.
E-mail: stanley@toyorobot.com



www.toyorobot.com