

ETB14M 單軸 /1-axis

▶ 皮帶驅動
Belt Driver



最大行程 Maximum Stroke	3050mm	最高速度 Maximum Speed	2400mm/s	馬達容量 Motor Output	200W	皮帶寬度 Belt Width	22mm	直線滑軌 Linear Guide	15X12.5-2 支
------------------------	--------	-----------------------	----------	----------------------	------	--------------------	------	----------------------	-------------

型號表示方式 Ordering Method

ETB14M-L 40-100-L - M20 - C4N5 - 參照右頁 - 0001

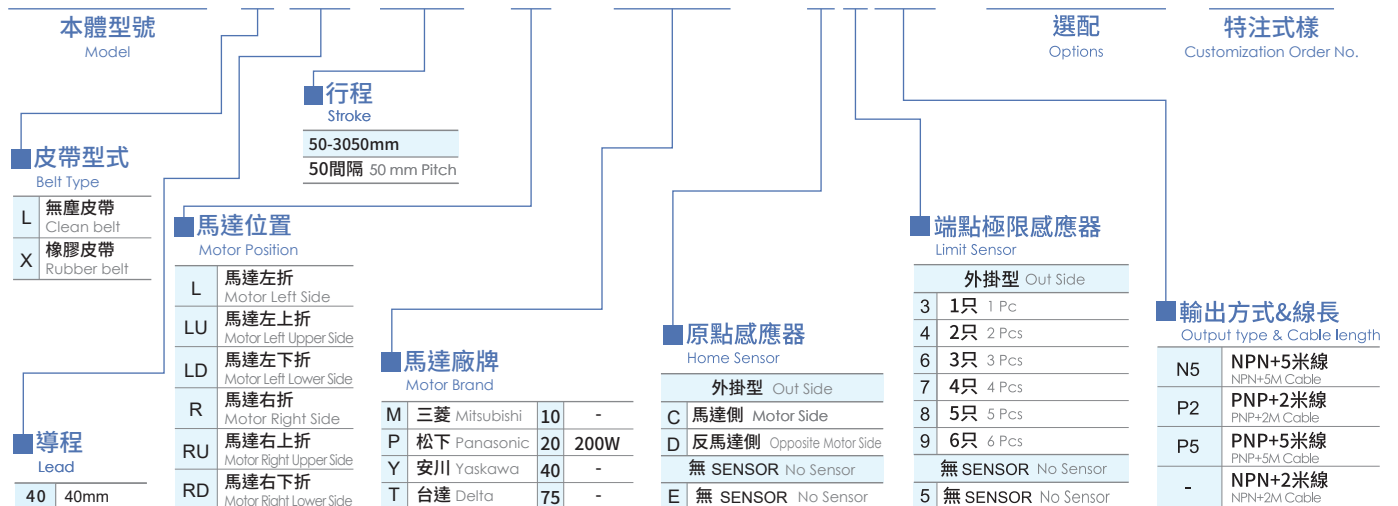

*感應器由客戶自行安裝,圖面最多示意為3只
*The sensors are installed by customers themselves, and the diagram shows a maximum of 3 sensors.

基本仕様 Specification

性能	位置重複精度 Repeatability	mm	±0.04	
	導程 Lead	mm	40	
	最高轉速 Maximum Rotating speed	rpm	3600	
	最高速度 Maximum linear speed	mm/s	2400	
	最大可搬重量 Maximum Payload	水平使用 Horizontal	kg	25
		垂直使用 Vertical	kg	
	定格推力 Rated Thrust	N	100	
標準行程 Stroke (increments) ※1	mm	50-3050mm/50 間隔 (50 increments)		
部品	AC 伺服馬達容量 AC Servo Motor Output	W	200	
	皮帶寬度 Belt Width	mm	22	
	高剛性直線滑軌 High Rigidity Linear Guide	mm	W15XH12.5	
	原點感應器 Home Sensor	外掛 Outside		T62N2 (NPN+2 米線) (NPN+2M Cable)

※1 行程 2000 以上，追加頂上蓋機構。
For strokes more than 2000mm, the top cover mechanism is added.

容許負載力距表 Allowable Overhang

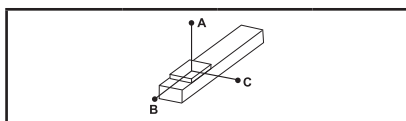

(單位 Unit: mm)

水平安裝 Horizontal Installation	A	B	C
10kg	1495	688	512
20kg	715	324	242
25kg	558	251	188

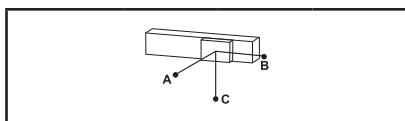

(單位 Unit: mm)

壁掛安裝 Wall Installation	A	B	C
10kg	512	688	1495
20kg	242	324	715
25kg	188	251	558

* 由於壁掛使用時上蓋會有突出滑座面的風險，如需選用需特注對應。
When using the wall mount upper cover will protrude on the surface of the slider. Please make sure to mention this while selecting.

靜額定扭矩 Static Loading Moment

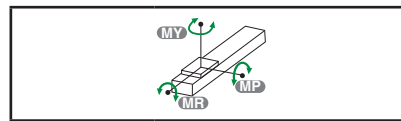

(單位 Unit: N.m)

MY	MP	MR
551	552	485

* 力矩表所表示的數據，代表荷重的重心位置於單一方向容許懸出的長度。
The data represented by the moment table is the center of gravity of the load. The length of the overhang is allowed in a single direction.
* 符合型錄規範的正常使用下，保證壽命為 10000 公里。
Operation life is 1,0000km when the product is using under the specified conditions.
* 倒吊使用無法套用標準規範，如有需求請洽詢我司業務。
Data information is not for ceiling-mount inverse use. Contact us for the details if you want to apply ceiling-mount inverse usage.
* 壽命及力矩是以馬達加速減速設定 0.4 秒計算。
The life and torque are calculated by setting the motor acceleration and deceleration for 0.4 seconds.

選配 Options

NL 外拉式注油嘴位置 External oil injection nozzle position			P 標準 PIN 孔 Standard PIN hole			EB 外觀黑色處理 Outer layer is treated with black oxide			MM 指定馬達出線方向 Selectable Cable Leading Direction			CMK 馬達傳動配件追加鍵槽 Additional keyway for motor drive parts				
代號 Code	說明 Instructions	需參照 Refer to	代號 Code	說明 Instructions	需參照 Refer to	代號 Code	說明 Instructions	需參照 Refer to	代號 Code	說明 Instructions	需參照 Refer to	代號 Code	說明 Instructions	需參照 Refer to		
NL	滑座左側 On The Left of The Slider	P.675 ~ P.676	P	標準 PIN 孔 Standard PIN hole	P.677	EB	黑色 Black	本體 Main Body	P.678	MW	朝上 Upper side	P.679 ~ P.680	CMK	單邊 (限定馬達側) Single (Limited to the motor side)	鍵槽式皮帶輪 Keyway Belt Pulley	P.681 ~ P.682
NR	滑座右側 On The Right of The Slider						原色 Original color	不銹鋼板材 Stainless steel plate		ML	朝左 Left side					
NRL	滑座雙邊注油 Slide both sides for oil injection						螺絲 Screw	MR		朝右 Right side						

ETB14M 單軸 /1-axis



L 馬達左折 Motor Left Side



• CAD圖面可至www.toyorobot.com下載 •
Please download the CAD file from TOYO's website : www.toyorobot.com

單位 Unit : mm

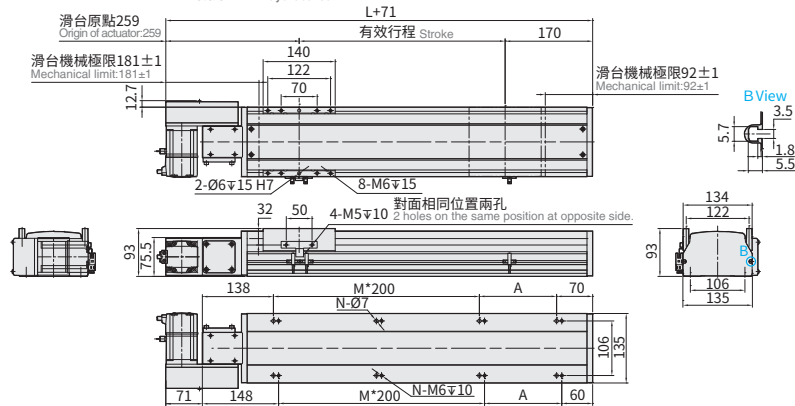

有效行程 Stroke	50	100	150	200	250	300	350	400	450	500	550	600	650	700	750	800	850	900	950	1000	1050	1100	1150	1200	1250	1300	1350	1400	1450	1500	1550					
極限行程 Limit Stroke (±1)	66	116	166	216	266	316	366	416	466	516	566	616	666	716	766	816	866	916	966	1016	1066	1116	1166	1216	1266	1316	1366	1416	1466	1516	1566					
L	408	458	508	558	608	658	708	758	808	858	908	958	1008	1058	1108	1158	1208	1258	1308	1358	1408	1458	1508	1558	1608	1658	1708	1758	1808	1858	1908					
A	200	50	100	150	200	50	100	150	200	50	100	150	200	50	100	150	200	50	100	150	200	50	100	150	200	50	100	150	200	50	100					
M	0	1	1	1	2	2	2	2	2	3	3	3	3	4	4	4	4	5	5	5	5	5	5	6	6	6	6	7	7	7	8	8				
N	4	6	6	6	6	8	8	8	8	10	10	10	10	12	12	12	12	14	14	14	14	14	16	16	16	16	18	18	18	18	20	20				
KG	8.2	8.6	9	9.5	10	10.5	11	11.4	12	12.4	13	13.4	13.9	14.4	14.9	15.4	15.9	16.4	16.9	17.3	17.9	18.5	19.1	19.7	20.3	20.9	21.5	22.1	22.7	23.3	23.9					
線速度 Linear Speed mm/s	導程 Lead 40		2400																																	

有效行程 Stroke	1600	1650	1700	1750	1800	1850	1900	1950	2000	2050	2100	2150	2200	2250	2300	2350	2400	2450	2500	2550	2600	2650	2700	2750	2800	2850	2900	2950	3000	3050						
極限行程 Limit Stroke (±1)	1616	1666	1716	1766	1816	1866	1916	1966	2016	2066	2116	2166	2216	2266	2316	2366	2416	2466	2516	2566	2616	2666	2716	2766	2816	2866	2916	2966	3016	3066						
L	1958	2008	2058	2108	2158	2208	2258	2308	2358	2408	2458	2508	2558	2608	2658	2708	2758	2808	2858	2908	2958	3008	3058	3108	3158	3208	3258	3308	3358	3408						
A	150	200	50	100	150	200	50	100	150	200	50	100	150	200	50	100	150	200	50	100	150	200	50	100	150	200	50	100	150	200						
M	8	8	9	9	9	9	10	10	10	10	11	11	11	11	12	12	12	12	13	13	13	13	14	14	14	14	15	15	15	15						
N	20	20	22	22	22	22	24	24	24	24	26	26	26	26	28	28	28	28	30	30	30	30	32	32	32	32	34	34	34	34						
KG	24.5	25.1	25.7	26.3	26.9	27.5	28.1	28.7	29.3	29.9	30.5	31.1	31.7	32.3	32.9	33.5	34.1	34.7	35.3	35.9	36.5	37.1	37.7	38.3	38.9	39.5	40.1	40.7	41.3	41.9						
線速度 Linear Speed mm/s	導程 Lead 40		2400																																	

R 馬達右折 Motor Right Side



• CAD圖面可至www.toyorobot.com下載 •
Please download the CAD file from TOYO's website : www.toyorobot.com

單位 Unit : mm

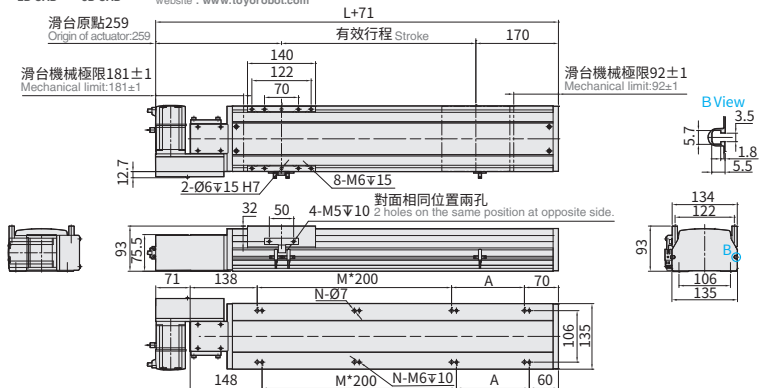

有效行程 Stroke	50	100	150	200	250	300	350	400	450	500	550	600	650	700	750	800	850	900	950	1000	1050	1100	1150	1200	1250	1300	1350	1400	1450	1500	1550					
極限行程 Limit Stroke (±1)	66	116	166	216	266	316	366	416	466	516	566	616	666	716	766	816	866	916	966	1016	1066	1116	1166	1216	1266	1316	1366	1416	1466	1516	1566					
L	408	458	508	558	608	658	708	758	808	858	908	958	1008	1058	1108	1158	1208	1258	1308	1358	1408	1458	1508	1558	1608	1658	1708	1758	1808	1858	1908					
A	200	50	100	150	200	50	100	150	200	50	100	150	200	50	100	150	200	50	100	150	200	50	100	150	200	50	100	150	200	50	100					
M	0	1	1	1	2	2	2	2	2	3	3	3	3	4	4	4	4	5	5	5	5	5	6	6	6	6	7	7	7	8	8					
N	4	6	6	6	6	8	8	8	8	10	10	10	10	12	12	12	12	14	14	14	14	14	16	16	16	16	18	18	18	18	20	20				
KG	8.2	8.6	9	9.5	10	10.5	11	11.4	12	12.4	13	13.4	13.9	14.4	14.9	15.4	15.9	16.4	16.9	17.3	17.9	18.5	19.1	19.7	20.3	20.9	21.5	22.1	22.7	23.3	23.9					
線速度 Linear Speed mm/s	導程 Lead 40		2400																																	

有效行程 Stroke	1600	1650	1700	1750	1800	1850	1900	1950	2000	2050	2100	2150	2200	2250	2300	2350	2400	2450	2500	2550	2600	2650	2700	2750	2800	2850	2900	2950	3000	3050						
極限行程 Limit Stroke (±1)	1616	1666	1716	1766	1816	1866	1916	1966	2016	2066	2116	2166	2216	2266	2316	2366	2416	2466	2516	2566	2616	2666	2716	2766	2816	2866	2916	2966	3016	3066						
L	1958	2008	2058	2108	2158	2208	2258	2308	2358	2408	2458	2508	2558	2608	2658	2708	2758	2808	2858	2908	2958	3008	3058	3108	3158	3208	3258	3308	3358	3408						
A	150	200	50	100	150	200	50	100	150	200	50	100	150	200	50	100	150	200	50	100	150	200	50	100	150	200	50	100	150	200						
M	8	8	9	9	9	9	10	10	10	10	11	11	11	11	12	12	12	12	13	13	13	13	14	14	14	14	15	15	15	15						
N	20	20	22	22	22	22	24	24	24	24	26	26	26	26	28	28	28	28	30	30	30	30	32	32	32	32	34	34	34	34						
KG	24.5	25.1	25.7	26.3	26.9	27.5	28.1	28.7	29.3	29.9	30.5	31.1	31.7	32.3	32.9	33.5	34.1	34.7	35.3	35.9	36.5	37.1	37.7	38.3	38.9	39.5	40.1	40.7	41.3	41.9						
線速度 Linear Speed mm/s	導程 Lead 40		2400																																	

LU 馬達左上折 Motor Left Upper Side



● CAD圖面可至www.toyorobot.com下載 ●
 Please download the CAD file from TOYO's website : www.toyorobot.com

單位 Unit : mm

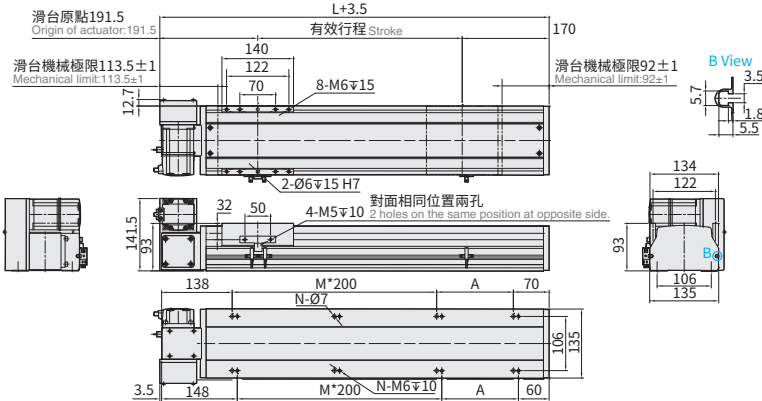

有效行程 Stroke	50	100	150	200	250	300	350	400	450	500	550	600	650	700	750	800	850	900	950	1000	1050	1100	1150	1200	1250	1300	1350	1400	1450	1500	1550					
極限行程 Limit Stroke (± 1)	66	116	166	216	266	316	366	416	466	516	566	616	666	716	766	816	866	916	966	1016	1066	1116	1166	1216	1266	1316	1366	1416	1466	1516	1566					
L	408	458	508	558	608	658	708	758	808	858	908	958	1008	1058	1108	1158	1208	1258	1308	1358	1408	1458	1508	1558	1608	1658	1708	1758	1808	1858	1908					
A	200	50	100	150	200	50	100	150	200	50	100	150	200	50	100	150	200	50	100	150	200	50	100	150	200	50	100	150	200	50	100					
M	0	1	1	1	1	2	2	2	2	3	3	3	3	4	4	4	4	5	5	5	5	6	6	6	6	7	7	7	7	8	8					
N	4	6	6	6	6	8	8	8	8	10	10	10	10	12	12	12	12	14	14	14	14	16	16	16	16	18	18	18	18	20	20					
KG	8.2	8.6	9	9.5	10	10.5	11	11.4	12	12.4	13	13.4	13.9	14.4	14.9	15.4	15.9	16.4	16.9	17.3	17.9	18.5	19.1	19.7	20.3	20.9	21.5	22.1	22.7	23.3	23.9					
線速度 Linear Speed mm/s	導程 Lead 40		2400																																	

有效行程 Stroke	1600	1650	1700	1750	1800	1850	1900	1950	2000	2050	2100	2150	2200	2250	2300	2350	2400	2450	2500	2550	2600	2650	2700	2750	2800	2850	2900	2950	3000	3050						
極限行程 Limit Stroke (± 1)	1616	1666	1716	1766	1816	1866	1916	1966	2016	2066	2116	2166	2216	2266	2316	2366	2416	2466	2516	2566	2616	2666	2716	2766	2816	2866	2916	2966	3016	3066						
L	1958	2008	2058	2108	2158	2208	2258	2308	2358	2408	2458	2508	2558	2608	2658	2708	2758	2808	2858	2908	2958	3008	3058	3108	3158	3208	3258	3308	3358	3408						
A	150	200	50	100	150	200	50	100	150	200	50	100	150	200	50	100	150	200	50	100	150	200	50	100	150	200	50	100	150	200						
M	8	8	9	9	9	9	10	10	10	10	11	11	11	11	12	12	12	12	13	13	13	13	14	14	14	14	15	15	15	15						
N	20	20	22	22	22	22	24	24	24	24	26	26	26	26	28	28	28	28	30	30	30	30	32	32	32	32	34	34	34	34						
KG	24.5	25.1	25.7	26.3	26.9	27.5	28.1	28.7	29.3	29.9	30.5	31.1	31.7	32.3	32.9	33.5	34.1	34.7	35.3	35.9	36.5	37.1	37.7	38.3	38.9	39.5	40.1	40.7	41.3	41.9						
線速度 Linear Speed mm/s	導程 Lead 40		2400																																	

RU 馬達右上折 Motor Right Upper Side



● CAD圖面可至www.toyorobot.com下載 ●
 Please download the CAD file from TOYO's website : www.toyorobot.com

單位 Unit : mm

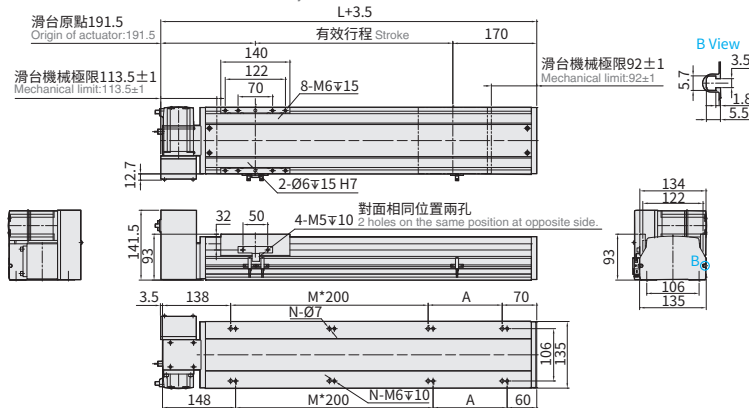

有效行程 Stroke	50	100	150	200	250	300	350	400	450	500	550	600	650	700	750	800	850	900	950	1000	1050	1100	1150	1200	1250	1300	1350	1400	1450	1500	1550					
極限行程 Limit Stroke (± 1)	66	116	166	216	266	316	366	416	466	516	566	616	666	716	766	816	866	916	966	1016	1066	1116	1166	1216	1266	1316	1366	1416	1466	1516	1566					
L	408	458	508	558	608	658	708	758	808	858	908	958	1008	1058	1108	1158	1208	1258	1308	1358	1408	1458	1508	1558	1608	1658	1708	1758	1808	1858	1908					
A	200	50	100	150	200	50	100	150	200	50	100	150	200	50	100	150	200	50	100	150	200	50	100	150	200	50	100	150	200	50	100					
M	0	1	1	1	1	2	2	2	2	3	3	3	3	4	4	4	4	5	5	5	5	6	6	6	6	7	7	7	7	8	8					
N	4	6	6	6	6	8	8	8	8	10	10	10	10	12	12	12	12	14	14	14	14	16	16	16	16	18	18	18	18	20	20					
KG	8.2	8.6	9	9.5	10	10.5	11	11.4	12	12.4	13	13.4	13.9	14.4	14.9	15.4	15.9	16.4	16.9	17.3	17.9	18.5	19.1	19.7	20.3	20.9	21.5	22.1	22.7	23.3	23.9					
線速度 Linear Speed mm/s	導程 Lead 40		2400																																	

有效行程 Stroke	1600	1650	1700	1750	1800	1850	1900	1950	2000	2050	2100	2150	2200	2250	2300	2350	2400	2450	2500	2550	2600	2650	2700	2750	2800	2850	2900	2950	3000	3050						
極限行程 Limit Stroke (± 1)	1616	1666	1716	1766	1816	1866	1916	1966	2016	2066	2116	2166	2216	2266	2316	2366	2416	2466	2516	2566	2616	2666	2716	2766	2816	2866	2916	2966	3016	3066						
L	1958	2008	2058	2108	2158	2208	2258	2308	2358	2408	2458	2508	2558	2608	2658	2708	2758	2808	2858	2908	2958	3008	3058	3108	3158	3208	3258	3308	3358	3408						
A	150	200	50	100	150	200	50	100	150	200	50	100	150	200	50	100	150	200	50	100	150	200	50	100	150	200	50	100	150	200						
M	8	8	9	9	9	9	10	10	10	10	11	11	11	11	12	12	12	12	13	13	13	13	14	14	14	14	15	15	15	15						
N	20	20	22	22	22	22	24	24	24	24	26	26	26	26	28	28	28	28	30	30	30	30	32	32	32	32	34	34	34	34						
KG	24.5	25.1	25.7	26.3	26.9	27.5	28.1	28.7	29.3	29.9	30.5	31.1	31.7	32.3	32.9	33.5	34.1	34.7	35.3	35.9	36.5	37.1	37.7	38.3	38.9	39.5	40.1	40.7	41.3	41.9						
線速度 Linear Speed mm/s	導程 Lead 40		2400																																	

ETB14M 單軸 /1-axis



LD 馬達左下折 Motor Left Lower Side



● CAD圖面可至www.toyorobot.com下載 ●

Please download the CAD file from TOYO's website : www.toyorobot.com

單位 Unit : mm

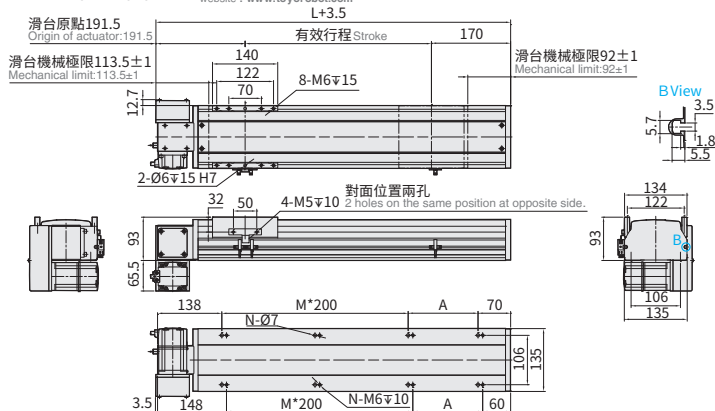

有效行程 Stroke	50	100	150	200	250	300	350	400	450	500	550	600	650	700	750	800	850	900	950	1000	1050	1100	1150	1200	1250	1300	1350	1400	1450	1500	1550
極限行程 Limit Stroke (±1)	66	116	166	216	266	316	366	416	466	516	566	616	666	716	766	816	866	916	966	1016	1066	1116	1166	1216	1266	1316	1366	1416	1466	1516	1566
L	408	458	508	558	608	658	708	758	808	858	908	958	1008	1058	1108	1158	1208	1258	1308	1358	1408	1458	1508	1558	1608	1658	1708	1758	1808	1858	1908
A	200	50	100	150	200	50	100	150	200	50	100	150	200	50	100	150	200	50	100	150	200	50	100	150	200	50	100	150	200	50	100
M	0	1	1	1	2	2	2	2	3	3	3	3	4	4	4	4	5	5	5	5	5	6	6	6	6	7	7	7	7	8	8
N	4	6	6	6	6	8	8	8	8	10	10	10	10	12	12	12	12	14	14	14	14	16	16	16	16	18	18	18	18	20	20
KG	8.2	8.6	9	9.5	10	10.5	11	11.4	12	12.4	13	13.4	13.9	14.4	14.9	15.4	15.9	16.4	16.9	17.3	17.9	18.5	19.1	19.7	20.3	20.9	21.5	22.1	22.7	23.3	23.9
線速度 Linear Speed mm/s	導程 Lead 40		2400																												

有效行程 Stroke	1600	1650	1700	1750	1800	1850	1900	1950	2000	2050	2100	2150	2200	2250	2300	2350	2400	2450	2500	2550	2600	2650	2700	2750	2800	2850	2900	2950	3000	3050
極限行程 Limit Stroke (±1)	1616	1666	1716	1766	1816	1866	1916	1966	2016	2066	2116	2166	2216	2266	2316	2366	2416	2466	2516	2566	2616	2666	2716	2766	2816	2866	2916	2966	3016	3066
L	1958	2008	2058	2108	2158	2208	2258	2308	2358	2408	2458	2508	2558	2608	2658	2708	2758	2808	2858	2908	2958	3008	3058	3108	3158	3208	3258	3308	3358	3408
A	150	200	50	100	150	200	50	100	150	200	50	100	150	200	50	100	150	200	50	100	150	200	50	100	150	200	50	100	150	200
M	8	8	9	9	9	9	10	10	10	10	11	11	11	11	12	12	12	12	13	13	13	13	14	14	14	14	15	15	15	15
N	20	20	22	22	22	22	24	24	24	24	26	26	26	26	28	28	28	28	30	30	30	30	32	32	32	32	34	34	34	34
KG	24.5	25.1	25.7	26.3	26.9	27.5	28.1	28.7	29.3	29.9	30.5	31.1	31.7	32.3	32.9	33.5	34.1	34.7	35.3	35.9	36.5	37.1	37.7	38.3	38.9	39.5	40.1	40.7	41.3	41.9
線速度 Linear Speed mm/s	導程 Lead 40		2400																											

RD 馬達右下折 Motor Right Lower Side



● CAD圖面可至www.toyorobot.com下載 ●

Please download the CAD file from TOYO's website : www.toyorobot.com

單位 Unit : mm

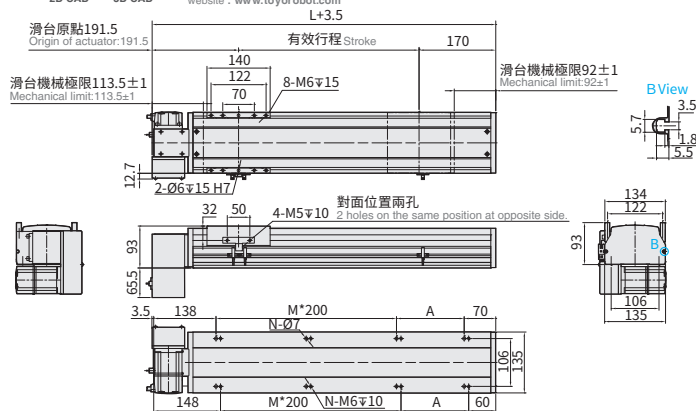

有效行程 Stroke	50	100	150	200	250	300	350	400	450	500	550	600	650	700	750	800	850	900	950	1000	1050	1100	1150	1200	1250	1300	1350	1400	1450	1500	1550
極限行程 Limit Stroke (±1)	66	116	166	216	266	316	366	416	466	516	566	616	666	716	766	816	866	916	966	1016	1066	1116	1166	1216	1266	1316	1366	1416	1466	1516	1566
L	408	458	508	558	608	658	708	758	808	858	908	958	1008	1058	1108	1158	1208	1258	1308	1358	1408	1458	1508	1558	1608	1658	1708	1758	1808	1858	1908
A	200	50	100	150	200	50	100	150	200	50	100	150	200	50	100	150	200	50	100	150	200	50	100	150	200	50	100	150	200	50	100
M	0	1	1	1	2	2	2	2	3	3	3	3	4	4	4	4	5	5	5	5	5	6	6	6	6	7	7	7	7	8	8
N	4	6	6	6	6	8	8	8	8	10	10	10	10	12	12	12	12	14	14	14	14	16	16	16	16	18	18	18	18	20	20
KG	8.2	8.6	9	9.5	10	10.5	11	11.4	12	12.4	13	13.4	13.9	14.4	14.9	15.4	15.9	16.4	16.9	17.3	17.9	18.5	19.1	19.7	20.3	20.9	21.5	22.1	22.7	23.3	23.9
線速度 Linear Speed mm/s	導程 Lead 40		2400																												

有效行程 Stroke	1600	1650	1700	1750	1800	1850	1900	1950	2000	2050	2100	2150	2200	2250	2300	2350	2400	2450	2500	2550	2600	2650	2700	2750	2800	2850	2900	2950	3000	3050
極限行程 Limit Stroke (±1)	1616	1666	1716	1766	1816	1866	1916	1966	2016	2066	2116	2166	2216	2266	2316	2366	2416	2466	2516	2566	2616	2666	2716	2766	2816	2866	2916	2966	3016	3066
L	1958	2008	2058	2108	2158	2208	2258	2308	2358	2408	2458	2508	2558	2608	2658	2708	2758	2808	2858	2908	2958	3008	3058	3108	3158	3208	3258	3308	3358	3408
A	150	200	50	100	150	200	50	100	150	200	50	100	150	200	50	100	150	200	50	100	150	200	50	100	150	200	50	100	150	200
M	8	8	9	9	9	9	10	10	10	10	11	11	11	11	12	12	12	12	13	13	13	13	14	14	14	14	15	15	15	15
N	20	20	22	22	22	22	24	24	24	24	26	26	26	26	28	28	28	28	30	30	30	30	32	32	32	32	34	34	34	34
KG	24.5	25.1	25.7	26.3	26.9	27.5	28.1	28.7	29.3	29.9	30.5	31.1	31.7	32.3	32.9	33.5	34.1	34.7	35.3	35.9	36.5	37.1	37.7	38.3	38.9	39.5	40.1	40.7	41.3	41.9
線速度 Linear Speed mm/s	導程 Lead 40		2400																											

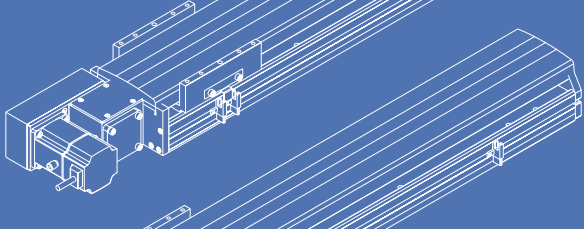

免費服務專線：大陸 400-875-0009 台灣 0800-800-893
Toll-Free Number China Taiwan

Memo

應用例
Application

一般 / 螺桿仕様
GTH / GTY / ETH / Y

一般 / 皮帶仕様
ETB

無塵 / 螺桿仕様
GCH / ECH

無塵 / 皮帶仕様
ECB

直交連結
XYGT / XTH / XYTB

參考資料
Reference

ETB Series

ETB5

ETB6

ETB10

ETB14M

ETB17M

ETB22M

ETB17M 單軸 /1-axis

▶ 皮帶驅動
Belt Driver



最大行程 Maximum Stroke	3050mm	最高速度 Maximum Speed	2400mm/s	馬達容量 Motor Output	400W	皮帶寬度 Belt Width	30mm	直線滑軌 Linear Guide	20X15-2 支
------------------------	--------	-----------------------	----------	----------------------	------	--------------------	------	----------------------	-----------

型號表示方式 Ordering Method

ETB17M-L 40- 50 - L - M40 - C4N5 - 參照右頁
Refer to the right page. - 0001

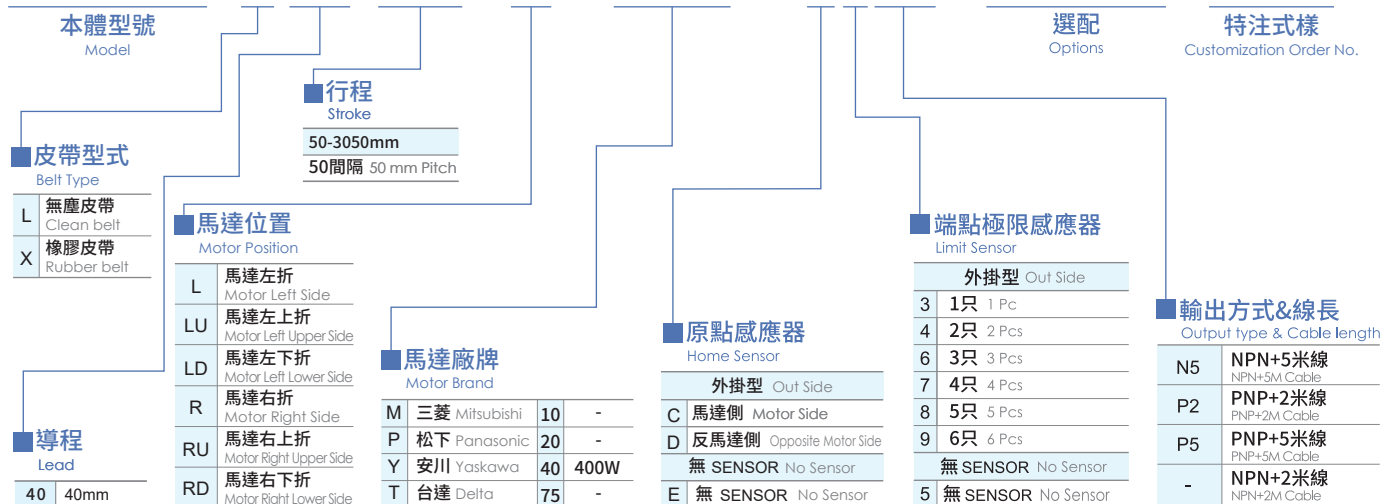

*感應器由客戶自行安裝,圖面最多示意為3只
*The sensors are installed by customers themselves, and the diagram shows a maximum of 3 sensors.

基本仕様 Specification

性能	位置重複精度 Repeatability	mm	±0.04	
	螺桿導程 Lead	mm	40	
	最高轉速 Maximum Rotating speed	rpm	3600	
	最高速度 Maximum linear speed	mm/s	2400	
	最大可搬重量 Maximum Payload	水平使用 Horizontal	kg	45
		垂直使用 Vertical	kg	
	定格推力 Rated Thrust	N	204	
標準行程 Stroke (increments) ※1	mm	50-3050mm/50 間隔 (50 increments)		
部品	AC 伺服馬達容量 AC Servo Motor Output	W	400	
	皮帶寬度 Belt Width	mm	30	
	高剛性直線滑軌 High Rigidity Linear Guide	mm	W20XH15	
	原點感應器 Home Sensor	外掛 Outside		T62N2 (NPN+2 米線) (NPN+2M Cable)

※1 行程 2000 以上，追加頂上蓋機構。
For strokes more than 2000mm, the top cover mechanism is added.

容許負載力距表 Allowable Overhang

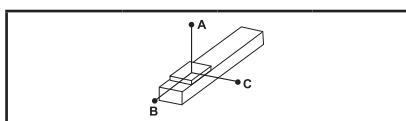

(單位 Unit : mm)

水平安裝 Horizontal Installation	A	B	C
10kg	2452	1133	974
20kg	1192	547	470
30kg	771	350	302
45kg	491	219	190

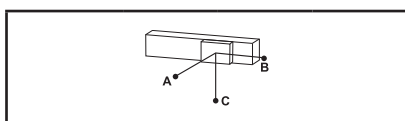

(單位 Unit : mm)

壁掛安裝 Wall Installation	A	B	C
10kg	974	1133	2452
20kg	470	547	1192
30kg	302	350	771
45kg	190	219	491

* 由於壁掛使用時上蓋會有突出滑座面的風險，如需用請注意對應。
When using the wall mount upper cover will protrude on the surface of the slider. Please make sure to mention this while selecting.

靜額定扭矩 Static Loading Moment

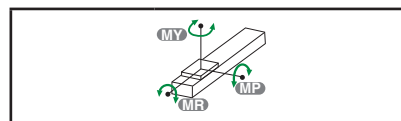

(單位 Unit : N.m)

MY	1032
MP	1034
MR	908

* 力矩表所表示的數據，代表荷重的重心位置於單一方向容許懸出的長度。
The data represented by the moment table is the center of gravity of the load. The length of the overhang is allowed in a single direction.
* 符合型錄規範的正常使用下，保證壽命為 10000 公里。
Operation life is 1,0000km when the product is using under the specified conditions.
* 倒吊使用無法套用標準規範，如有需求請洽詢我司業務。
Data information is not for ceiling-mount inverse use. Contact us for the details if you want to apply ceiling-mount inverse usage.
* 壽命及力矩是以馬達加減速設定 0.4 秒計算。
The life and torque are calculated by setting the motor acceleration and deceleration for 0.4 seconds.

選配 Options

NL			P			EB				MM			CMK			
外拉式注油嘴位置 External oil injection nozzle position			標準 PIN 孔 Standard PIN hole			外觀黑色處理 Outer layer is treated with black oxide				指定馬達出線方向 Selectable Cable Leading Direction			馬達傳動配件追加鍵槽 Additional keyway for motor drive parts			
代號 Code	說明 Instructions	需參照 Refer to	代號 Code	說明 Instructions	需參照 Refer to	代號 Code	說明 Instructions	範圍 Range	需參照 Refer to	代號 Code	說明 Instructions	需參照 Refer to	代號 Code	說明 Instructions	出貨型式 Shipment Type	需參照 Refer to
NL	滑座左側 On The Left of The Slider	P.675 ~ P.676	P	標準 PIN 孔 Standard PIN hole	P.677	EB	黑色 Black	本體 Main Body	P.678	MW	朝上 Upper side	P.679 ~ P.680	CMK	單邊 (限定馬達側) Single (Limited to the motor side)	鍵槽式皮帶輪 Keyway Belt Pulley	P.681 ~ P.682
NR	滑座右側 On The Right of The Slider						原色 Original color	不銹鋼板材 Stainless steel plate 螺絲 Screw		MM	朝下 Bottom side					
NRL	滑座雙邊注油 Slide both sides for oil injection						ML	朝左 Left side								
		MR	朝右 Right side													

ETB17M 單軸 /1-axis



L 馬達左折 Motor Left Side



• CAD圖面可至www.toyorobot.com下載 •
Please download the CAD file from TOYO's website : www.toyorobot.com

單位 Unit : mm

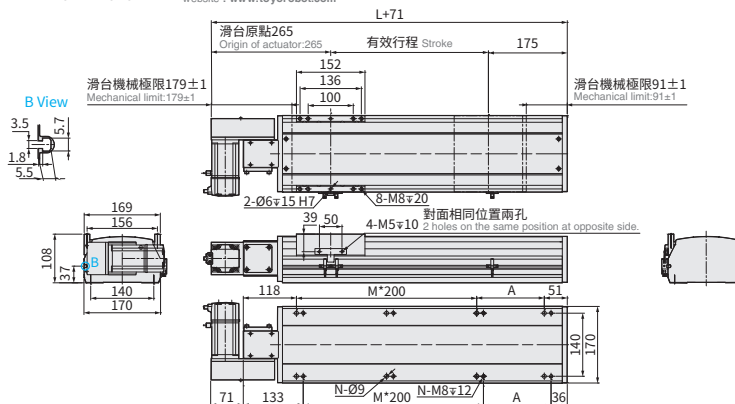

有效行程 Stroke	50	100	150	200	250	300	350	400	450	500	550	600	650	700	750	800	850	900	950	1000	1050	1100	1150	1200	1250	1300	1350	1400	1450	1500	1550					
極限行程 Limit Stroke (±1)	68	118	168	218	268	318	368	418	468	518	568	618	668	718	768	818	868	918	968	1018	1068	1118	1168	1218	1268	1318	1368	1418	1468	1518	1568					
L	419	469	519	569	619	669	719	769	819	869	919	969	1019	1069	1119	1169	1219	1269	1319	1369	1419	1469	1519	1569	1619	1669	1719	1769	1819	1869	1919					
A	50	100	150	200	250	300	350	400	450	500	550	600	650	700	750	800	850	900	950	1000	1050	1100	1150	1200	1250	1300	1350	1400	1450	1500	1550					
M	1	1	1	1	2	2	2	2	3	3	3	3	4	4	4	4	5	5	5	5	6	6	6	6	7	7	7	7	8	8	8					
N	6	6	6	6	8	8	8	8	10	10	10	10	12	12	12	12	14	14	14	14	16	16	16	16	18	18	18	18	20	20	20					
KG	10.2	12	13.8	14.6	15.4	16.1	16.9	17.7	18.5	19.2	20	20.8	21.6	22.3	23.1	23.9	24.7	25.4	26.2	27	27.8	28.6	29.4	30.2	31	31.8	32.6	33.4	34.2	35	35.8					
線速度 Linear Speed mm/s	導程 Lead 40		2400																																	

有效行程 Stroke	1600	1650	1700	1750	1800	1850	1900	1950	2000	2050	2100	2150	2200	2250	2300	2350	2400	2450	2500	2550	2600	2650	2700	2750	2800	2850	2900	2950	3000	3050						
極限行程 Limit Stroke (±1)	1618	1668	1718	1768	1818	1868	1918	1968	2018	2068	2118	2168	2218	2268	2318	2368	2418	2468	2518	2568	2618	2668	2718	2768	2818	2868	2918	2968	3018	3068						
L	1969	2019	2069	2119	2169	2219	2269	2319	2369	2419	2469	2519	2569	2619	2669	2719	2769	2819	2869	2919	2969	3019	3069	3119	3169	3219	3269	3319	3369	3419						
A	200	50	100	150	200	250	300	350	400	450	500	550	600	650	700	750	800	850	900	950	1000	1050	1100	1150	1200	1250	1300	1350	1400	1450	1500					
M	8	9	9	9	9	10	10	10	10	11	11	11	11	12	12	12	13	13	13	13	14	14	14	14	15	15	15	15	16	16						
N	20	22	22	22	22	24	24	24	24	26	26	26	26	28	28	28	30	30	30	30	32	32	32	32	34	34	34	34	36	36						
KG	36.6	37.4	38.2	39	39.8	40.6	41.4	42.2	43	43.8	44.6	45.4	46.2	47	47.8	48.6	49.4	50.2	51	51.8	52.6	53.4	54.2	55	55.8	56.6	57.4	58.2	59	59.8						
線速度 Linear Speed mm/s	導程 Lead 40		2400																																	

R 馬達右折 Motor Right Side



• CAD圖面可至www.toyorobot.com下載 •
Please download the CAD file from TOYO's website : www.toyorobot.com

單位 Unit : mm

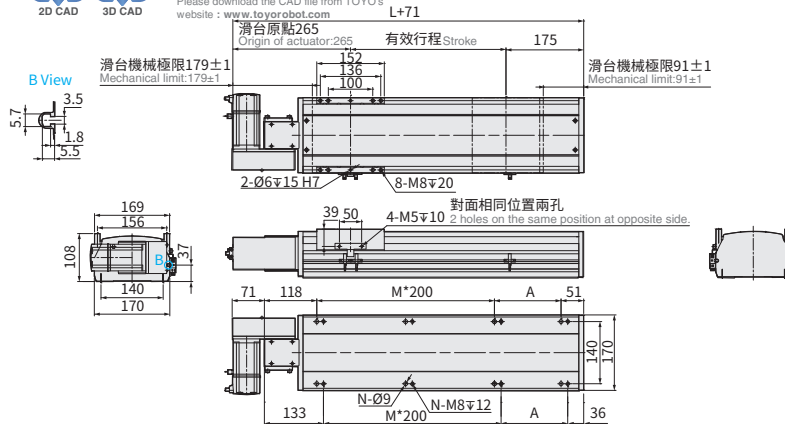

有效行程 Stroke	50	100	150	200	250	300	350	400	450	500	550	600	650	700	750	800	850	900	950	1000	1050	1100	1150	1200	1250	1300	1350	1400	1450	1500	1550					
極限行程 Limit Stroke (±1)	68	118	168	218	268	318	368	418	468	518	568	618	668	718	768	818	868	918	968	1018	1068	1118	1168	1218	1268	1318	1368	1418	1468	1518	1568					
L	419	469	519	569	619	669	719	769	819	869	919	969	1019	1069	1119	1169	1219	1269	1319	1369	1419	1469	1519	1569	1619	1669	1719	1769	1819	1869	1919					
A	50	100	150	200	250	300	350	400	450	500	550	600	650	700	750	800	850	900	950	1000	1050	1100	1150	1200	1250	1300	1350	1400	1450	1500	1550					
M	1	1	1	1	2	2	2	2	3	3	3	3	4	4	4	4	5	5	5	5	6	6	6	6	7	7	7	7	8	8	8					
N	6	6	6	6	8	8	8	8	10	10	10	10	12	12	12	12	14	14	14	14	16	16	16	16	18	18	18	18	20	20	20					
KG	10.2	12	13.8	14.6	15.4	16.1	16.9	17.7	18.5	19.2	20	20.8	21.6	22.3	23.1	23.9	24.7	25.4	26.2	27	27.8	28.6	29.4	30.2	31	31.8	32.6	33.4	34.2	35	35.8					
線速度 Linear Speed mm/s	導程 Lead 40		2400																																	

有效行程 Stroke	1600	1650	1700	1750	1800	1850	1900	1950	2000	2050	2100	2150	2200	2250	2300	2350	2400	2450	2500	2550	2600	2650	2700	2750	2800	2850	2900	2950	3000	3050						
極限行程 Limit Stroke (±1)	1618	1668	1718	1768	1818	1868	1918	1968	2018	2068	2118	2168	2218	2268	2318	2368	2418	2468	2518	2568	2618	2668	2718	2768	2818	2868	2918	2968	3018	3068						
L	1969	2019	2069	2119	2169	2219	2269	2319	2369	2419	2469	2519	2569	2619	2669	2719	2769	2819	2869	2919	2969	3019	3069	3119	3169	3219	3269	3319	3369	3419						
A	200	50	100	150	200	250	300	350	400	450	500	550	600	650	700	750	800	850	900	950	1000	1050	1100	1150	1200	1250	1300	1350	1400	1450	1500					
M	8	9	9	9	9	10	10	10	10	11	11	11	11	12	12	12	13	13	13	13	14	14	14	14	15	15	15	15	16	16						
N	20	22	22	22	22	24	24	24	24	26	26	26	26	28	28	28	30	30	30	30	32	32	32	32	34	34	34	34	36	36						
KG	36.6	37.4	38.2	39	39.8	40.6	41.4	42.2	43	43.8	44.6	45.4	46.2	47	47.8	48.6	49.4	50.2	51	51.8	52.6	53.4	54.2	55	55.8	56.6	57.4	58.2	59	59.8						
線速度 Linear Speed mm/s	導程 Lead 40		2400																																	

LU 馬達左上折 Motor Left Upper Side



• CAD圖面可至www.toyorobot.com下載 •
 Please download the CAD file from TOYO's website : www.toyorobot.com

單位 Unit : mm

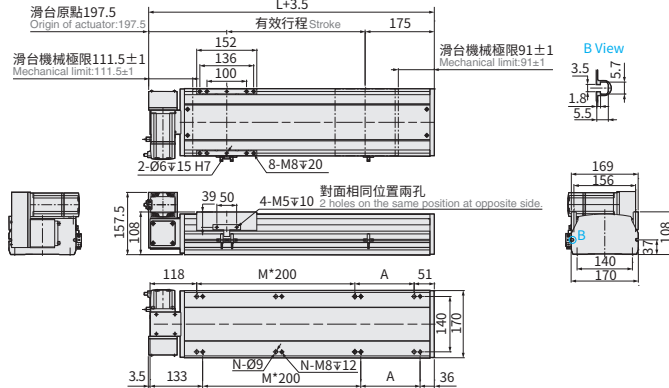

有效行程 Stroke	50	100	150	200	250	300	350	400	450	500	550	600	650	700	750	800	850	900	950	1000	1050	1100	1150	1200	1250	1300	1350	1400	1450	1500	1550					
極限行程 Limit Stroke (±1)	68	118	168	218	268	318	368	418	468	518	568	618	668	718	768	818	868	918	968	1018	1068	1118	1168	1218	1268	1318	1368	1418	1468	1518	1568					
L	419	469	519	569	619	669	719	769	819	869	919	969	1019	1069	1119	1169	1219	1269	1319	1369	1419	1469	1519	1569	1619	1669	1719	1769	1819	1869	1919					
A	50	100	150	200	50	100	150	200	50	100	150	200	50	100	150	200	50	100	150	200	50	100	150	200	50	100	150	200	50	100	150					
M	1	1	1	1	2	2	2	2	3	3	3	3	3	4	4	4	4	5	5	5	5	6	6	6	6	7	7	7	7	8	8					
N	6	6	6	6	8	8	8	8	10	10	10	10	12	12	12	12	14	14	14	14	16	16	16	16	18	18	18	18	20	20	20					
KG	10.2	12	13.8	14.6	15.4	16.1	16.9	17.7	18.5	19.2	20	20.8	21.6	22.3	23.1	23.9	24.7	25.4	26.2	27	27.8	28.6	29.4	30.2	31	31.8	32.6	33.4	34.2	35	35.8					
線速度 Linear Speed mm/s	導程 Lead 40		2400																																	

有效行程 Stroke	1600	1650	1700	1750	1800	1850	1900	1950	2000	2050	2100	2150	2200	2250	2300	2350	2400	2450	2500	2550	2600	2650	2700	2750	2800	2850	2900	2950	3000	3050						
極限行程 Limit Stroke (±1)	1618	1668	1718	1768	1818	1868	1918	1968	2018	2068	2118	2168	2218	2268	2318	2368	2418	2468	2518	2568	2618	2668	2718	2768	2818	2868	2918	2968	3018	3068						
L	1969	2019	2069	2119	2169	2219	2269	2319	2369	2419	2469	2519	2569	2619	2669	2719	2769	2819	2869	2919	2969	3019	3069	3119	3169	3219	3269	3319	3369	3419						
A	200	50	100	150	200	50	100	150	200	50	100	150	200	50	100	150	200	50	100	150	200	50	100	150	200	50	100	150	200	50						
M	8	9	9	9	9	10	10	10	10	10	11	11	11	11	12	12	12	12	13	13	13	13	14	14	14	14	15	15	15	16						
N	20	22	22	22	22	24	24	24	24	26	26	26	26	28	28	28	28	30	30	30	30	32	32	32	32	34	34	34	34	36						
KG	36.6	37.4	38.2	39	39.8	40.6	41.4	42.2	43	43.8	44.6	45.4	46.2	47	47.8	48.6	49.4	50.2	51	51.8	52.6	53.4	54.2	55	55.8	56.6	57.4	58.2	59	59.8						
線速度 Linear Speed mm/s	導程 Lead 40		2400																																	

RU 馬達右上折 Motor Right Upper Side



• CAD圖面可至www.toyorobot.com下載 •
 Please download the CAD file from TOYO's website : www.toyorobot.com

單位 Unit : mm

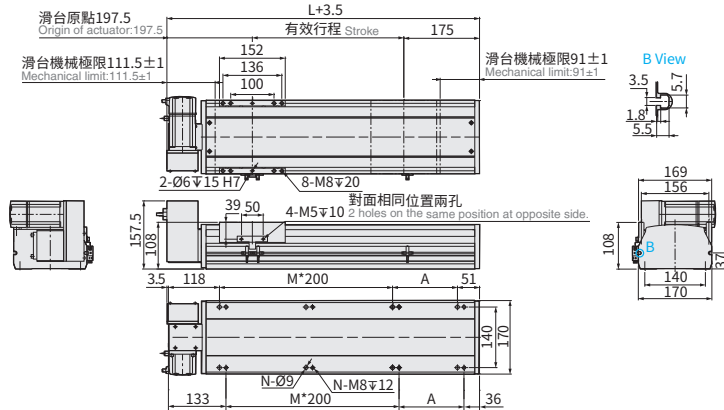

有效行程 Stroke	50	100	150	200	250	300	350	400	450	500	550	600	650	700	750	800	850	900	950	1000	1050	1100	1150	1200	1250	1300	1350	1400	1450	1500	1550					
極限行程 Limit Stroke (±1)	68	118	168	218	268	318	368	418	468	518	568	618	668	718	768	818	868	918	968	1018	1068	1118	1168	1218	1268	1318	1368	1418	1468	1518	1568					
L	419	469	519	569	619	669	719	769	819	869	919	969	1019	1069	1119	1169	1219	1269	1319	1369	1419	1469	1519	1569	1619	1669	1719	1769	1819	1869	1919					
A	50	100	150	200	50	100	150	200	50	100	150	200	50	100	150	200	50	100	150	200	50	100	150	200	50	100	150	200	50	100	150					
M	1	1	1	1	2	2	2	2	3	3	3	3	3	4	4	4	4	5	5	5	5	6	6	6	6	7	7	7	7	8	8					
N	6	6	6	6	8	8	8	8	10	10	10	10	12	12	12	12	14	14	14	14	16	16	16	16	18	18	18	18	20	20	20					
KG	10.2	12	13.8	14.6	15.4	16.1	16.9	17.7	18.5	19.2	20	20.8	21.6	22.3	23.1	23.9	24.7	25.4	26.2	27	27.8	28.6	29.4	30.2	31	31.8	32.6	33.4	34.2	35	35.8					
線速度 Linear Speed mm/s	導程 Lead 40		2400																																	

有效行程 Stroke	1600	1650	1700	1750	1800	1850	1900	1950	2000	2050	2100	2150	2200	2250	2300	2350	2400	2450	2500	2550	2600	2650	2700	2750	2800	2850	2900	2950	3000	3050						
極限行程 Limit Stroke (±1)	1618	1668	1718	1768	1818	1868	1918	1968	2018	2068	2118	2168	2218	2268	2318	2368	2418	2468	2518	2568	2618	2668	2718	2768	2818	2868	2918	2968	3018	3068						
L	1969	2019	2069	2119	2169	2219	2269	2319	2369	2419	2469	2519	2569	2619	2669	2719	2769	2819	2869	2919	2969	3019	3069	3119	3169	3219	3269	3319	3369	3419						
A	200	50	100	150	200	50	100	150	200	50	100	150	200	50	100	150	200	50	100	150	200	50	100	150	200	50	100	150	200	50						
M	8	9	9	9	9	10	10	10	10	10	11	11	11	11	12	12	12	12	13	13	13	13	14	14	14	14	15	15	15	16						
N	20	22	22	22	22	24	24	24	24	26	26	26	26	28	28	28	28	30	30	30	30	32	32	32	32	34	34	34	34	36						
KG	36.6	37.4	38.2	39	39.8	40.6	41.4	42.2	43	43.8	44.6	45.4	46.2	47	47.8	48.6	49.4	50.2	51	51.8	52.6	53.4	54.2	55	55.8	56.6	57.4	58.2	59	59.8						
線速度 Linear Speed mm/s	導程 Lead 40		2400																																	

ETB17M 單軸 /1-axis



LD 馬達左下折 Motor Left Lower Side



• CAD圖面可至www.toyorobot.com下載 •

Please download the CAD file from TOYO's website : www.toyorobot.com

單位 Unit : mm

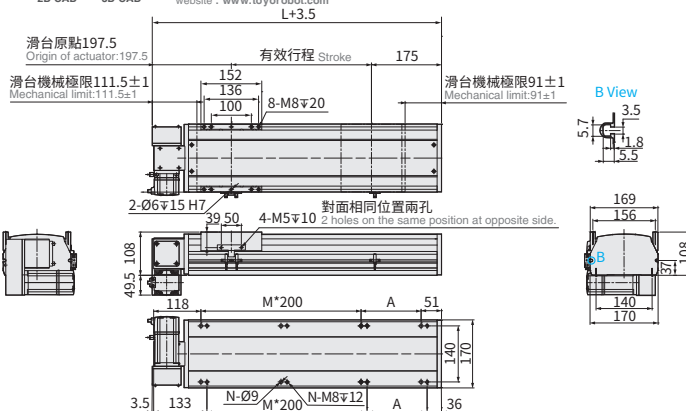

有效行程 Stroke	50	100	150	200	250	300	350	400	450	500	550	600	650	700	750	800	850	900	950	1000	1050	1100	1150	1200	1250	1300	1350	1400	1450	1500	1550					
極限行程 Limit Stroke (±1)	68	118	168	218	268	318	368	418	468	518	568	618	668	718	768	818	868	918	968	1018	1068	1118	1168	1218	1268	1318	1368	1418	1468	1518	1568					
L	419	469	519	569	619	669	719	769	819	869	919	969	1019	1069	1119	1169	1219	1269	1319	1369	1419	1469	1519	1569	1619	1669	1719	1769	1819	1869	1919					
A	50	100	150	200	250	300	350	400	450	500	550	600	650	700	750	800	850	900	950	1000	1050	1100	1150	1200	1250	1300	1350	1400	1450	1500	1550					
M	1	1	1	1	2	2	2	2	3	3	3	3	4	4	4	4	5	5	5	5	6	6	6	6	7	7	7	7	8	8	8					
N	6	6	6	6	8	8	8	8	10	10	10	10	12	12	12	12	14	14	14	14	16	16	16	16	18	18	18	18	20	20	20					
KG	10.2	12	13.8	14.6	15.4	16.1	16.9	17.7	18.5	19.2	20	20.8	21.6	22.3	23.1	23.9	24.7	25.4	26.2	27	27.8	28.6	29.4	30.2	31	31.8	32.6	33.4	34.2	35	35.8					
線速度 Linear Speed mm/s	導程 Lead 40		2400																																	

有效行程 Stroke	1600	1650	1700	1750	1800	1850	1900	1950	2000	2050	2100	2150	2200	2250	2300	2350	2400	2450	2500	2550	2600	2650	2700	2750	2800	2850	2900	2950	3000	3050						
極限行程 Limit Stroke (±1)	1618	1668	1718	1768	1818	1868	1918	1968	2018	2068	2118	2168	2218	2268	2318	2368	2418	2468	2518	2568	2618	2668	2718	2768	2818	2868	2918	2968	3018	3068						
L	1969	2019	2069	2119	2169	2219	2269	2319	2369	2419	2469	2519	2569	2619	2669	2719	2769	2819	2869	2919	2969	3019	3069	3119	3169	3219	3269	3319	3369	3419						
A	200	50	100	150	200	250	300	350	400	450	500	550	600	650	700	750	800	850	900	950	1000	1050	1100	1150	1200	1250	1300	1350	1400	1450						
M	8	9	9	9	9	10	10	10	10	11	11	11	11	12	12	12	13	13	13	13	13	14	14	14	14	15	15	15	15	16						
N	20	22	22	22	22	24	24	24	24	26	26	26	26	28	28	28	30	30	30	30	30	32	32	32	32	34	34	34	34	36						
KG	36.6	37.4	38.2	39	39.8	40.6	41.4	42.2	43	43.8	44.6	45.4	46.2	47	47.8	48.6	49.4	50.2	51	51.8	52.6	53.4	54.2	55	55.8	56.6	57.4	58.2	59	59.8						
線速度 Linear Speed mm/s	導程 Lead 40		2400																																	

RD 馬達右下折 Motor Right Lower Side



• CAD圖面可至www.toyorobot.com下載 •

Please download the CAD file from TOYO's website : www.toyorobot.com

單位 Unit : mm

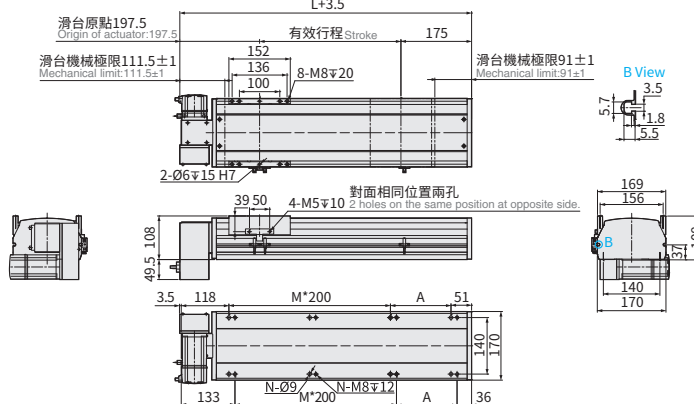

有效行程 Stroke	50	100	150	200	250	300	350	400	450	500	550	600	650	700	750	800	850	900	950	1000	1050	1100	1150	1200	1250	1300	1350	1400	1450	1500	1550					
極限行程 Limit Stroke (±1)	68	118	168	218	268	318	368	418	468	518	568	618	668	718	768	818	868	918	968	1018	1068	1118	1168	1218	1268	1318	1368	1418	1468	1518	1568					
L	419	469	519	569	619	669	719	769	819	869	919	969	1019	1069	1119	1169	1219	1269	1319	1369	1419	1469	1519	1569	1619	1669	1719	1769	1819	1869	1919					
A	50	100	150	200	250	300	350	400	450	500	550	600	650	700	750	800	850	900	950	1000	1050	1100	1150	1200	1250	1300	1350	1400	1450	1500	1550					
M	1	1	1	1	2	2	2	2	3	3	3	3	4	4	4	4	5	5	5	5	6	6	6	6	7	7	7	7	8	8	8					
N	6	6	6	6	8	8	8	8	10	10	10	10	12	12	12	12	14	14	14	14	16	16	16	16	18	18	18	18	20	20	20					
KG	10.2	12	13.8	14.6	15.4	16.1	16.9	17.7	18.5	19.2	20	20.8	21.6	22.3	23.1	23.9	24.7	25.4	26.2	27	27.8	28.6	29.4	30.2	31	31.8	32.6	33.4	34.2	35	35.8					
線速度 Linear Speed mm/s	導程 Lead 40		2400																																	

有效行程 Stroke	1600	1650	1700	1750	1800	1850	1900	1950	2000	2050	2100	2150	2200	2250	2300	2350	2400	2450	2500	2550	2600	2650	2700	2750	2800	2850	2900	2950	3000	3050						
極限行程 Limit Stroke (±1)	1618	1668	1718	1768	1818	1868	1918	1968	2018	2068	2118	2168	2218	2268	2318	2368	2418	2468	2518	2568	2618	2668	2718	2768	2818	2868	2918	2968	3018	3068						
L	1969	2019	2069	2119	2169	2219	2269	2319	2369	2419	2469	2519	2569	2619	2669	2719	2769	2819	2869	2919	2969	3019	3069	3119	3169	3219	3269	3319	3369	3419						
A	200	50	100	150	200	250	300	350	400	450	500	550	600	650	700	750	800	850	900	950	1000	1050	1100	1150	1200	1250	1300	1350	1400	1450						
M	8	9	9	9	9	10	10	10	10	11	11	11	11	12	12	12	13	13	13	13	13	14	14	14	14	15	15	15	15	16						
N	20	22	22	22	22	24	24	24	24	26	26	26	26	28	28	28	30	30	30	30	30	32	32	32	32	34	34	34	34	36						
KG	36.6	37.4	38.2	39	39.8	40.6	41.4	42.2	43	43.8	44.6	45.4	46.2	47	47.8	48.6	49.4	50.2	51	51.8	52.6	53.4	54.2	55	55.8	56.6	57.4	58.2	59	59.8						
線速度 Linear Speed mm/s	導程 Lead 40		2400																																	

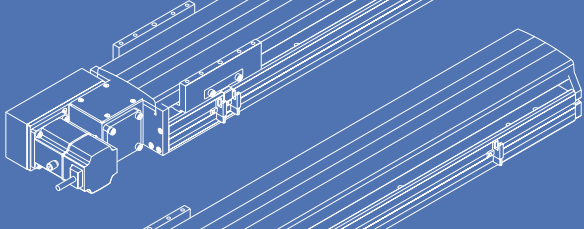

免費服務專線：大陸 400-875-0009 台灣 0800-800-893
Toll-Free Number China Taiwan

Memo

應用例
Application

一般 / 螺桿仕様
GTH / GTY / ETH / Y

一般 / 皮帶仕様
ETB

無塵 / 螺桿仕様
GCH / ECH

無塵 / 皮帶仕様
ECB

直交連結
XYGT / XTH / XYTB

參考資料
Reference

ETB Series

ETB5

ETB6

ETB10

ETB14M

ETB17M

ETB22M



最大行程 Maximum Stroke	3500mm	最高速度 Maximum Speed	2400mm/s	馬達容量 Motor Output	750W	皮帶寬度 Belt Width	50mm	直線滑軌 Linear Guide	23X18-2 支
------------------------	--------	-----------------------	----------	----------------------	------	--------------------	------	----------------------	-----------

型號表示方式 Ordering Method

ETB22M-L 40-100-L - M75 - C4N5 - 參照右頁 - 0001

參照右頁 Refer to the right page.

本體型號 Model	行程 Stroke	馬達位置 Motor Position	馬達廠牌 Motor Brand	原點感應器 Home Sensor	端點極限感應器 Limit Sensor	輸出方式&線長 Output type & Cable length
皮帶型式 Belt Type	50-3500mm 50mm間隔 50 mm Pitch	L 馬達左折 Motor Left Side LU 馬達左上折 Motor Left Upper Side LD 馬達左下折 Motor Left Lower Side R 馬達右折 Motor Right Side RU 馬達右上折 Motor Right Upper Side RD 馬達右下折 Motor Right Lower Side	M 三菱 Mitsubishi 10 - P 松下 Panasonic 20 - Y 安川 Yaskawa 40 - T 台達 Delta 75 750W	外掛型 Out Side C 馬達側 Motor Side D 反馬達側 Opposite Motor Side 無 SENSOR No Sensor E 無 SENSOR No Sensor	外掛型 Out Side 3 1只 1 Pc 4 2只 2 Pcs 6 3只 3 Pcs 7 4只 4 Pcs 8 5只 5 Pcs 9 6只 6 Pcs 無 SENSOR No Sensor 5 無 SENSOR No Sensor	N5 NPN+5米線 NPN+5M Cable P2 PNP+2米線 PNP+2M Cable P5 PNP+5米線 PNP+5M Cable - NPN+2米線 NPN+2M Cable
導程 Lead						
40 40mm						

*感應器由客戶自行安裝,圖面最多示意為3只
*The sensors are installed by customers themselves, and the diagram shows a maximum of 3 sensors.

基本仕様 Specification

性能	位置重複精度 Repeatability	mm	±0.04	
	導程 Lead	mm	40	
	最高轉速 Maximum Rotating speed	rpm	3600	
	最高速度 Maximum linear speed	mm/s	2400	
	最大可搬重量 Maximum Payload	水平使用 Horizontal	kg	85
		垂直使用 Vertical	kg	
	定格推力 Rated Thrust	N	367	
標準行程 Stroke (increments) ※1	mm	50-3500mm/50 間隔 (50 increments)		
部品	AC 伺服馬達容量 AC Servo Motor Output	W	750	
	皮帶寬度 Belt Width	mm	50	
	高剛性直線滑軌 High Rigidity Linear Guide	mm	W23XH18	
	原點感應器 Home Sensor	外掛 Outside		T62N2 (NPN+2 米線) (NPN+2M Cable)

※1 行程 2000 以上，追加頂上蓋機構。
For strokes more than 2000mm, the top cover mechanism is added.

容許負載力距表 Allowable Overhang

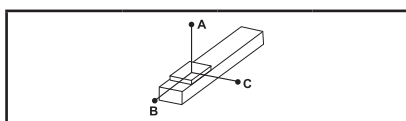

(單位 Unit: mm)

水平安裝 Horizontal Installation	A	B	C
45kg	1323	600	419
65kg	876	391	274
85kg	640	281	197

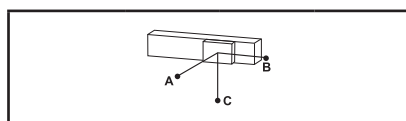

(單位 Unit: mm)

壁掛安裝 Wall Installation	A	B	C
45kg	419	600	1323
65kg	274	391	876
85kg	197	281	640

* 由於壁掛使用時上蓋會有突出滑座面的風險，如需選用需特別對應。
When using the wall mount upper cover will protrude on the surface of the slider. Please make sure to mention this while selecting.

靜額定扭矩 Static Loading Moment

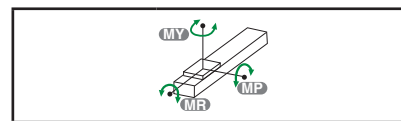

(單位 Unit: N.m)

MY	2052
MP	2052
MR	1810

* 力矩表所表示的數據，代表荷重的重心位置於單一方向容許懸出的長度。
The data represented by the moment table is the center of gravity of the load. The length of the overhang is allowed in a single direction.
* 符合型錄規範的正常情況下，保證壽命為 10000 公里。
Operation life is 1,0000km when the product is using under the specified conditions.
* 倒吊使用無法套用標準規範，如有需求請洽詢我司業務。
Data information is not for ceiling-mount inverse use. Contact us for the details if you want to apply ceiling-mount inverse usage.
* 壽命及力矩是以馬達加減速設定 0.4 秒計算。
The life and torque are calculated by setting the motor acceleration and deceleration for 0.4 seconds.

選配 Options

NL			P			EB				MM			CMK			
外拉式注油嘴位置 External oil injection nozzle position			標準 PIN 孔 Standard PIN hole			外觀黑色處理 Outer layer is treated with black oxide				指定馬達出線方向 Selectable Cable Leading Direction			馬達傳動配件追加鍵槽 Additional keyway for motor drive parts			
代號 Code	說明 Instructions	需參照 Refer to	代號 Code	說明 Instructions	需參照 Refer to	代號 Code	說明 Instructions	範圍 Range	需參照 Refer to	代號 Code	說明 Instructions	需參照 Refer to	代號 Code	說明 Instructions	出貨型式 Shipment type	需參照 Refer to
NL	滑座左側 On The Left of The Slider	P.675 ~ P.676	P	標準 PIN 孔 Standard PIN hole	P.677	EB	黑色 Black	本體 Main Body	P.678	MW	朝上 Upper side	P.679 ~ P.680	CMK	單邊 (限定馬達側) Single (Limited to the motor side)	鍵槽式皮帶輪 Keyway Belt Pulley	P.681 ~ P.682
NR	滑座右側 On The Right of The Slider							不銹鋼板材 Stainless steel plate		MM	朝下 Bottom side					
NRL	滑座雙邊注油 Slide both sides for oil injection						原色 Original color	ML		朝左 Left side						
			MR	朝右 Right side												

ETB22M 單軸 /1-axis



L 馬達左折 Motor Left Side



• CAD圖面可至www.toyorobot.com下載 •
Please download the CAD file from TOYO's website: www.toyorobot.com

單位 Unit : mm

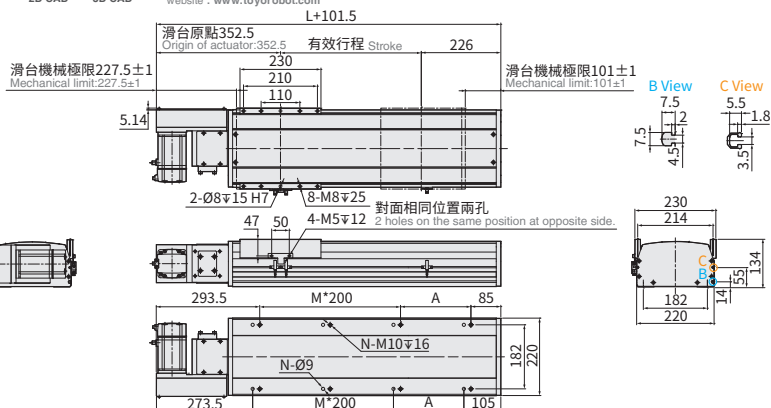

有效行程 Stroke	50	100	150	200	250	300	350	400	450	500	550	600	650	700	750	800	850	900	950	1000	1050	1100	1150	1200	1250	1300	1350	1400	1450	1500	1550		
極限行程 Limit Stroke (±1)	70	120	170	220	270	320	370	420	470	520	570	620	670	720	770	820	870	920	970	1020	1070	1120	1170	1220	1270	1320	1370	1420	1470	1520	1570		
L	527	577	627	677	727	777	827	877	927	977	1027	1077	1127	1177	1227	1277	1327	1377	1427	1477	1527	1577	1627	1677	1727	1777	1827	1877	1927	1977	2027		
A	50	100	150	200	50	100	150	200	50	100	150	200	50	100	150	200	50	100	150	200	50	100	150	200	50	100	150	200	50	100	150		
M	1	1	1	1	2	2	2	2	3	3	3	3	4	4	4	4	5	5	5	5	6	6	6	7	7	7	7	8	8	8			
N	6	6	6	6	8	8	8	8	10	10	10	10	12	12	12	12	14	14	14	14	16	16	16	16	18	18	18	18	20	20	20		
KG	28.8	30	31.2	32.4	33.6	34.8	36	37.2	38.4	39.6	40.8	42	43.2	44.4	45.6	46.8	48	49.2	50.4	51.6	52.8	54	55.2	56.4	59.2	59.8	60	61.2	62.4	63.6	64.8		
線速度 Linear Speed mm/s	2400																																
導程 Lead	40																																

有效行程 Stroke	1600	1650	1700	1750	1800	1850	1900	1950	2000	2050	2100	2150	2200	2250	2300	2350	2400	2450	2500	2550	2600	2650	2700	2750	2800	2850	2900	2950	3000	3050			
極限行程 Limit Stroke (±1)	1620	1670	1720	1770	1820	1870	1920	1970	2020	2070	2120	2170	2220	2270	2320	2370	2420	2470	2520	2570	2620	2670	2720	2770	2820	2870	2920	2970	3020	3070			
L	2077	2127	2177	2227	2277	2327	2377	2427	2477	2527	2577	2627	2677	2727	2777	2827	2877	2927	2977	3027	3077	3127	3177	3227	3277	3327	3377	3427	3477	3527			
A	200	50	100	150	200	50	100	150	200	50	100	150	200	50	100	150	200	50	100	150	200	50	100	150	200	50	100	150	200	50			
M	8	9	9	9	9	10	10	10	10	11	11	11	11	12	12	12	12	13	13	13	13	13	14	14	14	14	15	15	15	16			
N	20	22	22	22	22	24	24	24	24	26	26	26	26	28	28	28	28	30	30	30	30	30	32	32	32	32	34	34	34	36			
KG	66	67.2	68.4	69.6	70.8	72	73.2	74.4	75.6	76.8	78	79.2	80.4	81.6	82.8	84	85.2	86.4	87.6	88.8	90	91.2	92.4	93.6	94.8	96	97.2	98.4	99.6	100.8			
線速度 Linear Speed mm/s	2400																																
導程 Lead	40																																

※ 由於版面限制，無法列出所有行程資訊，總長 L = 行程 +477；極限行程為有效行程 +20。
Due to the limitation of the layout, it's not able to list out full information of the stroke. Total Length of L = Stroke+477 and the stroke limit is +20 of the stroke range.

R 馬達右折 Motor Right Side



• CAD圖面可至www.toyorobot.com下載 •
Please download the CAD file from TOYO's website: www.toyorobot.com

單位 Unit : mm

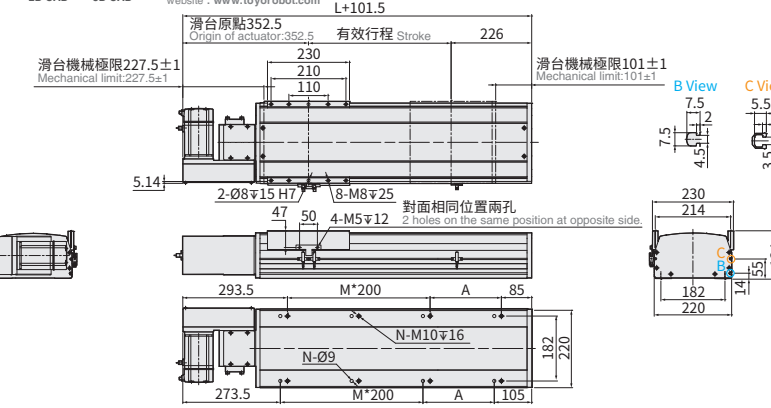

有效行程 Stroke	50	100	150	200	250	300	350	400	450	500	550	600	650	700	750	800	850	900	950	1000	1050	1100	1150	1200	1250	1300	1350	1400	1450	1500	1550		
極限行程 Limit Stroke (±1)	70	120	170	220	270	320	370	420	470	520	570	620	670	720	770	820	870	920	970	1020	1070	1120	1170	1220	1270	1320	1370	1420	1470	1520	1570		
L	527	577	627	677	727	777	827	877	927	977	1027	1077	1127	1177	1227	1277	1327	1377	1427	1477	1527	1577	1627	1677	1727	1777	1827	1877	1927	1977	2027		
A	50	100	150	200	50	100	150	200	50	100	150	200	50	100	150	200	50	100	150	200	50	100	150	200	50	100	150	200	50	100	150		
M	1	1	1	1	2	2	2	2	3	3	3	3	4	4	4	4	5	5	5	5	6	6	6	7	7	7	7	8	8	8			
N	6	6	6	6	8	8	8	8	10	10	10	10	12	12	12	12	14	14	14	14	16	16	16	16	18	18	18	18	20	20	20		
KG	28.8	30	31.2	32.4	33.6	34.8	36	37.2	38.4	39.6	40.8	42	43.2	44.4	45.6	46.8	48	49.2	50.4	51.6	52.8	54	55.2	56.4	59.2	59.8	60	61.2	62.4	63.6	64.8		
線速度 Linear Speed mm/s	2400																																
導程 Lead	40																																

有效行程 Stroke	1600	1650	1700	1750	1800	1850	1900	1950	2000	2050	2100	2150	2200	2250	2300	2350	2400	2450	2500	2550	2600	2650	2700	2750	2800	2850	2900	2950	3000	3050			
極限行程 Limit Stroke (±1)	1620	1670	1720	1770	1820	1870	1920	1970	2020	2070	2120	2170	2220	2270	2320	2370	2420	2470	2520	2570	2620	2670	2720	2770	2820	2870	2920	2970	3020	3070			
L	2077	2127	2177	2227	2277	2327	2377	2427	2477	2527	2577	2627	2677	2727	2777	2827	2877	2927	2977	3027	3077	3127	3177	3227	3277	3327	3377	3427	3477	3527			
A	200	50	100	150	200	50	100	150	200	50	100	150	200	50	100	150	200	50	100	150	200	50	100	150	200	50	100	150	200	50			
M	8	9	9	9	9	10	10	10	10	11	11	11	11	12	12	12	12	13	13	13	13	13	14	14	14	14	15	15	15	16			
N	20	22	22	22	22	24	24	24	24	26	26	26	26	28	28	28	28	30	30	30	30	30	32	32	32	32	34	34	34	36			
KG	66	67.2	68.4	69.6	70.8	72	73.2	74.4	75.6	76.8	78	79.2	80.4	81.6	82.8	84	85.2	86.4	87.6	88.8	90	91.2	92.4	93.6	94.8	96	97.2	98.4	99.6	100.8			
線速度 Linear Speed mm/s	2400																																
導程 Lead	40																																

※ 由於版面限制，無法列出所有行程資訊，總長 L = 行程 +477；極限行程為有效行程 +20。
Due to the limitation of the layout, it's not able to list out full information of the stroke. Total Length of L = Stroke+477 and the stroke limit is +20 of the stroke range.

LU 馬達左上折 Motor Left Upper Side



CAD圖面可至www.toyorobot.com下載
 Please download the CAD file from TOYO's website : www.toyorobot.com

單位 Unit : mm

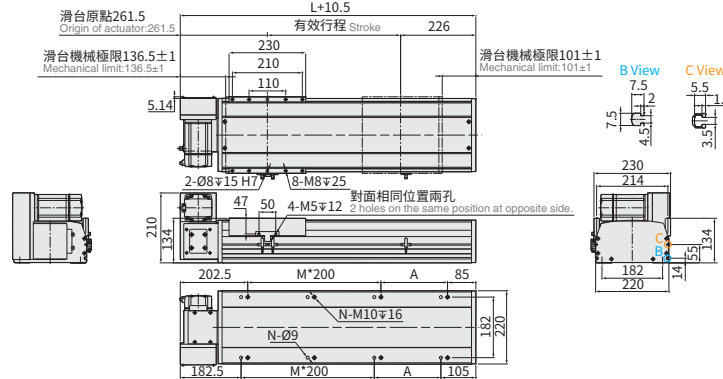

有效行程 Stroke	50	100	150	200	250	300	350	400	450	500	550	600	650	700	750	800	850	900	950	1000	1050	1100	1150	1200	1250	1300	1350	1400	1450	1500	1550	
極限行程 Limit Stroke (±1)	70	120	170	220	270	320	370	420	470	520	570	620	670	720	770	820	870	920	970	1020	1070	1120	1170	1220	1270	1320	1370	1420	1470	1520	1570	
L	527	577	627	677	727	777	827	877	927	977	1027	1077	1127	1177	1227	1277	1327	1377	1427	1477	1527	1577	1627	1677	1727	1777	1827	1877	1927	1977	2027	
A	50	100	150	200	250	300	350	400	450	500	550	600	650	700	750	800	850	900	950	1000	1050	1100	1150	1200	1250	1300	1350	1400	1450	1500	1550	
M	1	1	1	1	2	2	2	2	3	3	3	3	4	4	4	4	5	5	5	5	6	6	6	6	7	7	7	7	8	8	8	
N	6	6	6	6	8	8	8	8	10	10	10	10	12	12	12	12	14	14	14	14	16	16	16	16	18	18	18	18	20	20	20	
KG	28.8	30	31.2	32.4	33.6	34.8	36	37.2	38.4	39.6	40.8	42	43.2	44.4	45.6	46.8	48	49.2	50.4	51.6	52.8	54	55.2	56.4	59.2	59.8	60	61.2	62.4	63.6	64.8	
線速度 Linear Speed mm/s	2400																															
導程 Lead 40																																

有效行程 Stroke	1600	1650	1700	1750	1800	1850	1900	1950	2000	2050	2100	2150	2200	2250	2300	2350	2400	2450	2500	2550	2600	2650	2700	2750	2800	2850	2900	2950	3000	3050		
極限行程 Limit Stroke (±1)	1620	1670	1720	1770	1820	1870	1920	1970	2020	2070	2120	2170	2220	2270	2320	2370	2420	2470	2520	2570	2620	2670	2720	2770	2820	2870	2920	2970	3020	3070		
L	2077	2127	2177	2227	2277	2327	2377	2427	2477	2527	2577	2627	2677	2727	2777	2827	2877	2927	2977	3027	3077	3127	3177	3227	3277	3327	3377	3427	3477	3527		
A	200	50	100	150	200	250	300	350	400	450	500	550	600	650	700	750	800	850	900	950	1000	1050	1100	1150	1200	1250	1300	1350	1400	1450	1500	
M	8	9	9	9	9	10	10	10	10	11	11	11	11	12	12	12	12	13	13	13	13	14	14	14	14	15	15	15	15	16		
N	20	22	22	22	22	24	24	24	24	26	26	26	26	28	28	28	28	30	30	30	30	32	32	32	32	34	34	34	34	36		
KG	66	67.2	68.4	69.6	70.8	72	73.2	74.4	75.6	76.8	78	79.2	80.4	81.6	82.8	84	85.2	86.4	87.6	88.8	90	91.2	92.4	93.6	94.8	96	97.2	98.4	99.6	100.8		
線速度 Linear Speed mm/s	2400																															
導程 Lead 40																																

※ 由於版面限制，無法列出所有行程資訊，總長 L = 行程 +477; 極限行程為有效行程 +20。
 Due to the limitation of the layout, it's not able to list out full information of the stroke. Total Length of L = Stroke+477 and the stroke limit is +20 of the stroke range.

RU 馬達右上折 Motor Right Upper Side



CAD圖面可至www.toyorobot.com下載
 Please download the CAD file from TOYO's website : www.toyorobot.com

單位 Unit : mm

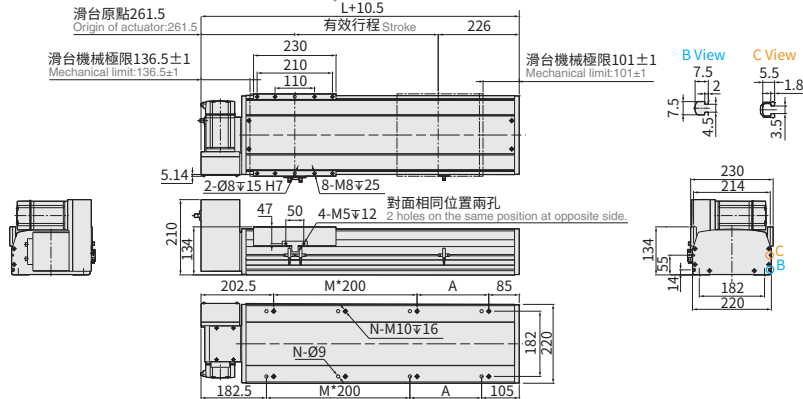

有效行程 Stroke	50	100	150	200	250	300	350	400	450	500	550	600	650	700	750	800	850	900	950	1000	1050	1100	1150	1200	1250	1300	1350	1400	1450	1500	1550	
極限行程 Limit Stroke (±1)	70	120	170	220	270	320	370	420	470	520	570	620	670	720	770	820	870	920	970	1020	1070	1120	1170	1220	1270	1320	1370	1420	1470	1520	1570	
L	527	577	627	677	727	777	827	877	927	977	1027	1077	1127	1177	1227	1277	1327	1377	1427	1477	1527	1577	1627	1677	1727	1777	1827	1877	1927	1977	2027	
A	50	100	150	200	250	300	350	400	450	500	550	600	650	700	750	800	850	900	950	1000	1050	1100	1150	1200	1250	1300	1350	1400	1450	1500	1550	
M	1	1	1	1	2	2	2	2	3	3	3	3	4	4	4	4	5	5	5	5	6	6	6	6	7	7	7	7	8	8	8	
N	6	6	6	6	8	8	8	8	10	10	10	10	12	12	12	12	14	14	14	14	16	16	16	16	18	18	18	18	20	20	20	
KG	28.8	30	31.2	32.4	33.6	34.8	36	37.2	38.4	39.6	40.8	42	43.2	44.4	45.6	46.8	48	49.2	50.4	51.6	52.8	54	55.2	56.4	59.2	59.8	60	61.2	62.4	63.6	64.8	
線速度 Linear Speed mm/s	2400																															
導程 Lead 40																																

有效行程 Stroke	1600	1650	1700	1750	1800	1850	1900	1950	2000	2050	2100	2150	2200	2250	2300	2350	2400	2450	2500	2550	2600	2650	2700	2750	2800	2850	2900	2950	3000	3050		
極限行程 Limit Stroke (±1)	1620	1670	1720	1770	1820	1870	1920	1970	2020	2070	2120	2170	2220	2270	2320	2370	2420	2470	2520	2570	2620	2670	2720	2770	2820	2870	2920	2970	3020	3070		
L	2077	2127	2177	2227	2277	2327	2377	2427	2477	2527	2577	2627	2677	2727	2777	2827	2877	2927	2977	3027	3077	3127	3177	3227	3277	3327	3377	3427	3477	3527		
A	200	50	100	150	200	250	300	350	400	450	500	550	600	650	700	750	800	850	900	950	1000	1050	1100	1150	1200	1250	1300	1350	1400	1450	1500	
M	8	9	9	9	9	10	10	10	10	11	11	11	11	12	12	12	12	13	13	13	13	14	14	14	14	15	15	15	15	16		
N	20	22	22	22	22	24	24	24	24	26	26	26	26	28	28	28	28	30	30	30	30	32	32	32	32	34	34	34	34	36		
KG	66	67.2	68.4	69.6	70.8	72	73.2	74.4	75.6	76.8	78	79.2	80.4	81.6	82.8	84	85.2	86.4	87.6	88.8	90	91.2	92.4	93.6	94.8	96	97.2	98.4	99.6	100.8		
線速度 Linear Speed mm/s	2400																															
導程 Lead 40																																

※ 由於版面限制，無法列出所有行程資訊，總長 L = 行程 +477; 極限行程為有效行程 +20。
 Due to the limitation of the layout, it's not able to list out full information of the stroke. Total Length of L = Stroke+477 and the stroke limit is +20 of the stroke range.

ETB Series

ETB5

ETB6

ETB10

ETB14M

ETB17M

ETB22M

ETB22M 單軸 /1-axis



LD 馬達左下折 Motor Left Lower Side



CAD圖面可至 www.toyorobot.com 下載
Please download the CAD file from TOYO's website : www.toyorobot.com

單位 Unit : mm

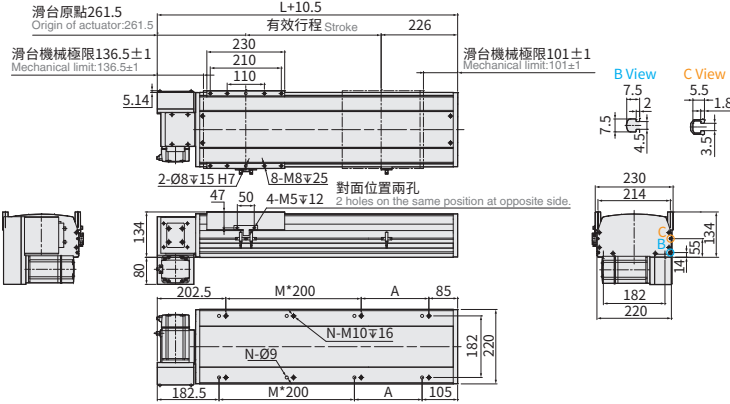

有效行程 Stroke	50	100	150	200	250	300	350	400	450	500	550	600	650	700	750	800	850	900	950	1000	1050	1100	1150	1200	1250	1300	1350	1400	1450	1500	1550					
極限行程 Limit Stroke (±1)	70	120	170	220	270	320	370	420	470	520	570	620	670	720	770	820	870	920	970	1020	1070	1120	1170	1220	1270	1320	1370	1420	1470	1520	1570					
L	527	577	627	677	727	777	827	877	927	977	1027	1077	1127	1177	1227	1277	1327	1377	1427	1477	1527	1577	1627	1677	1727	1777	1827	1877	1927	1977	2027					
A	50	100	150	200	50	100	150	200	50	100	150	200	50	100	150	200	50	100	150	200	50	100	150	200	50	100	150	200	50	100	150					
M	1	1	1	1	2	2	2	2	3	3	3	3	4	4	4	4	5	5	5	5	6	6	6	6	6	7	7	7	8	8	8					
N	6	6	6	6	8	8	8	8	10	10	10	10	12	12	12	12	14	14	14	14	16	16	16	16	18	18	18	18	20	20	20					
KG	28.8	30	31.2	32.4	33.6	34.8	36	37.2	38.4	39.6	40.8	42	43.2	44.4	45.6	46.8	48	49.2	50.4	51.6	52.8	54	55.2	56.4	59.2	59.8	60	61.2	62.4	63.6	64.8					
線速度 Linear Speed mm/s	導程 Lead 40		2400																																	

有效行程 Stroke	1600	1650	1700	1750	1800	1850	1900	1950	2000	2050	2100	2150	2200	2250	2300	2350	2400	2450	2500	2550	2600	2650	2700	2750	2800	2850	2900	2950	3000	3050						
極限行程 Limit Stroke (±1)	1620	1670	1720	1770	1820	1870	1920	1970	2020	2070	2120	2170	2220	2270	2320	2370	2420	2470	2520	2570	2620	2670	2720	2760	2820	2870	2920	2970	3020	3070						
L	2077	2127	2177	2227	2277	2327	2377	2427	2477	2527	2577	2627	2677	2727	2777	2827	2877	2927	2977	3027	3077	3127	3177	3227	3277	3327	3377	3427	3477	3527						
A	200	50	100	150	200	50	100	150	200	50	100	150	200	50	100	150	200	50	100	150	200	50	100	150	200	50	100	150	200	50						
M	8	9	9	9	9	10	10	10	10	11	11	11	11	12	12	12	12	13	13	13	13	14	14	14	14	15	15	15	15	16						
N	20	22	22	22	22	24	24	24	24	26	26	26	26	28	28	28	28	30	30	30	30	32	32	32	32	34	34	34	34	36						
KG	66	67.2	68.4	69.6	70.8	72	73.2	74.4	75.6	76.8	78	79.2	80.4	81.6	82.8	84	85.2	86.4	87.6	88.8	90	91.2	92.4	93.6	94.8	96	97.2	98.4	99.6	100.8						
線速度 Linear Speed mm/s	導程 Lead 40		2400																																	

* 由於版面限制，無法列出所有行程資訊，總長 L = 行程 +477；極限行程為有效行程 +20。
Due to the limitation of the layout, it's not able to list out full information of the stroke. Total Length of L = Stroke+477 and the stroke limit is +20 of the stroke range.

RD 馬達右下折 Motor Right Lower Side



CAD圖面可至 www.toyorobot.com 下載
Please download the CAD file from TOYO's website : www.toyorobot.com

單位 Unit : mm

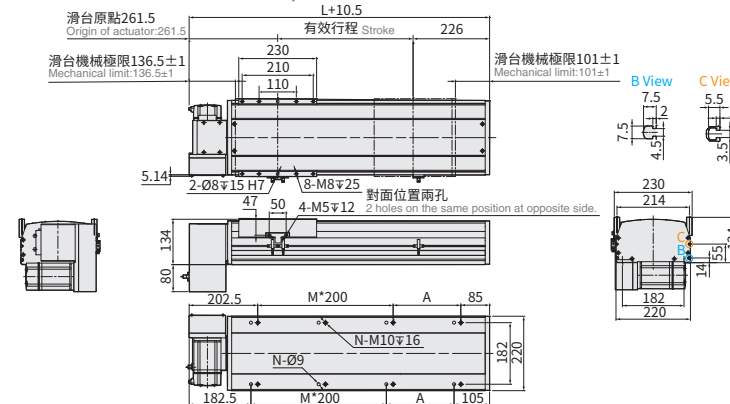

有效行程 Stroke	50	100	150	200	250	300	350	400	450	500	550	600	650	700	750	800	850	900	950	1000	1050	1100	1150	1200	1250	1300	1350	1400	1450	1500	1550					
極限行程 Limit Stroke (±1)	70	120	170	220	270	320	370	420	470	520	570	620	670	720	770	820	870	920	970	1020	1070	1120	1170	1220	1270	1320	1370	1420	1470	1520	1570					
L	527	577	627	677	727	777	827	877	927	977	1027	1077	1127	1177	1227	1277	1327	1377	1427	1477	1527	1577	1627	1677	1727	1777	1827	1877	1927	1977	2027					
A	50	100	150	200	50	100	150	200	50	100	150	200	50	100	150	200	50	100	150	200	50	100	150	200	50	100	150	200	50	100	150					
M	1	1	1	1	2	2	2	2	3	3	3	3	4	4	4	4	5	5	5	5	6	6	6	6	6	7	7	7	8	8	8					
N	6	6	6	6	8	8	8	8	10	10	10	10	12	12	12	12	14	14	14	14	16	16	16	16	18	18	18	18	20	20	20					
KG	28.8	30	31.2	32.4	33.6	34.8	36	37.2	38.4	39.6	40.8	42	43.2	44.4	45.6	46.8	48	49.2	50.4	51.6	52.8	54	55.2	56.4	59.2	59.8	60	61.2	62.4	63.6	64.8					
線速度 Linear Speed mm/s	導程 Lead 40		2400																																	

有效行程 Stroke	1600	1650	1700	1750	1800	1850	1900	1950	2000	2050	2100	2150	2200	2250	2300	2350	2400	2450	2500	2550	2600	2650	2700	2750	2800	2850	2900	2950	3000	3050						
極限行程 Limit Stroke (±1)	1620	1670	1720	1770	1820	1870	1920	1970	2020	2070	2120	2170	2220	2270	2320	2370	2420	2470	2520	2570	2620	2670	2720	2760	2820	2870	2920	2970	3020	3070						
L	2077	2127	2177	2227	2277	2327	2377	2427	2477	2527	2577	2627	2677	2727	2777	2827	2877	2927	2977	3027	3077	3127	3177	3227	3277	3327	3377	3427	3477	3527						
A	200	50	100	150	200	50	100	150	200	50	100	150	200	50	100	150	200	50	100	150	200	50	100	150	200	50	100	150	200	50						
M	8	9	9	9	9	10	10	10	10	11	11	11	11	12	12	12	12	13	13	13	13	14	14	14	14	15	15	15	15	16						
N	20	22	22	22	22	24	24	24	24	26	26	26	26	28	28	28	28	30	30	30	30	32	32	32	32	34	34	34	34	36						
KG	66	67.2	68.4	69.6	70.8	72	73.2	74.4	75.6	76.8	78	79.2	80.4	81.6	82.8	84	85.2	86.4	87.6	88.8	90	91.2	92.4	93.6	94.8	96	97.2	98.4	99.6	100.8						
線速度 Linear Speed mm/s	導程 Lead 40		2400																																	

* 由於版面限制，無法列出所有行程資訊，總長 L = 行程 +477；極限行程為有效行程 +20。
Due to the limitation of the layout, it's not able to list out full information of the stroke. Total Length of L = Stroke+477 and the stroke limit is +20 of the stroke range.